



Kursus "Lightning & Surge Protection" Surge Protective Devices

Cawangan Kejuruteraan Elektrik



3 September
2020

1.1 Scope

Lightning Protection System

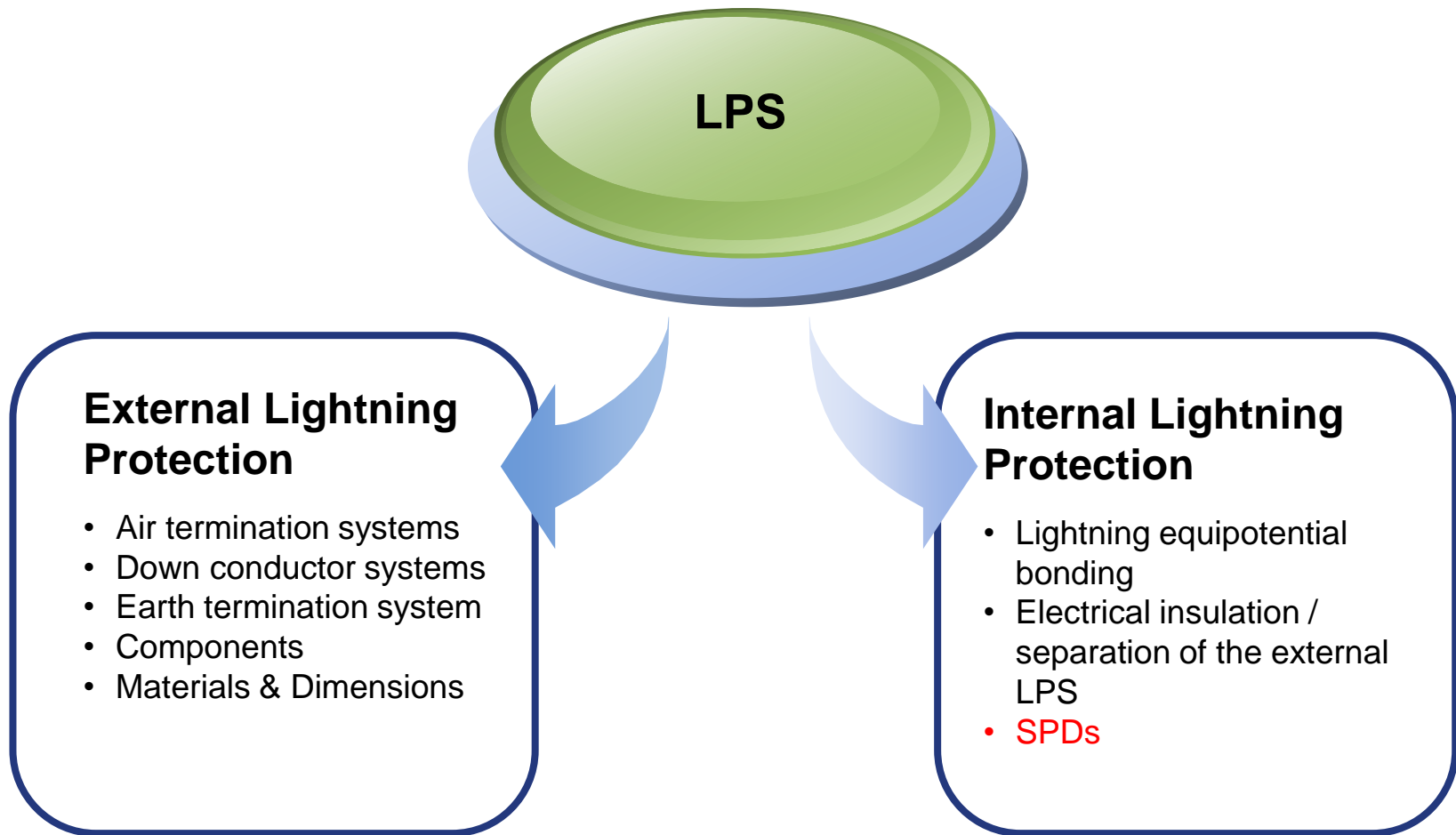

1.2 Terms & Definitions

Lightning Electromagnetic Impulse (LEMP)

- Electromagnetic effects of lightning current via resistive, inductive & capacitive coupling that create surges and radiated electromagnetic fields

Resistively coupled transients are caused by differences in potential between two connected earths.

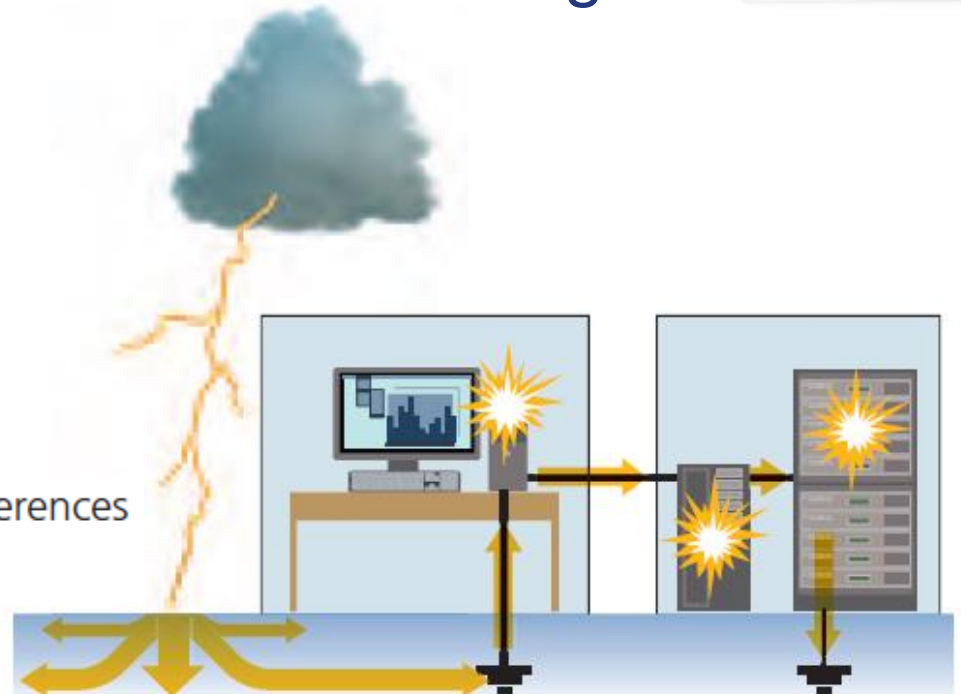

1.2 Terms & Definitions

Lightning Electromagnetic Impulse (LEMP)

- inductive coupling

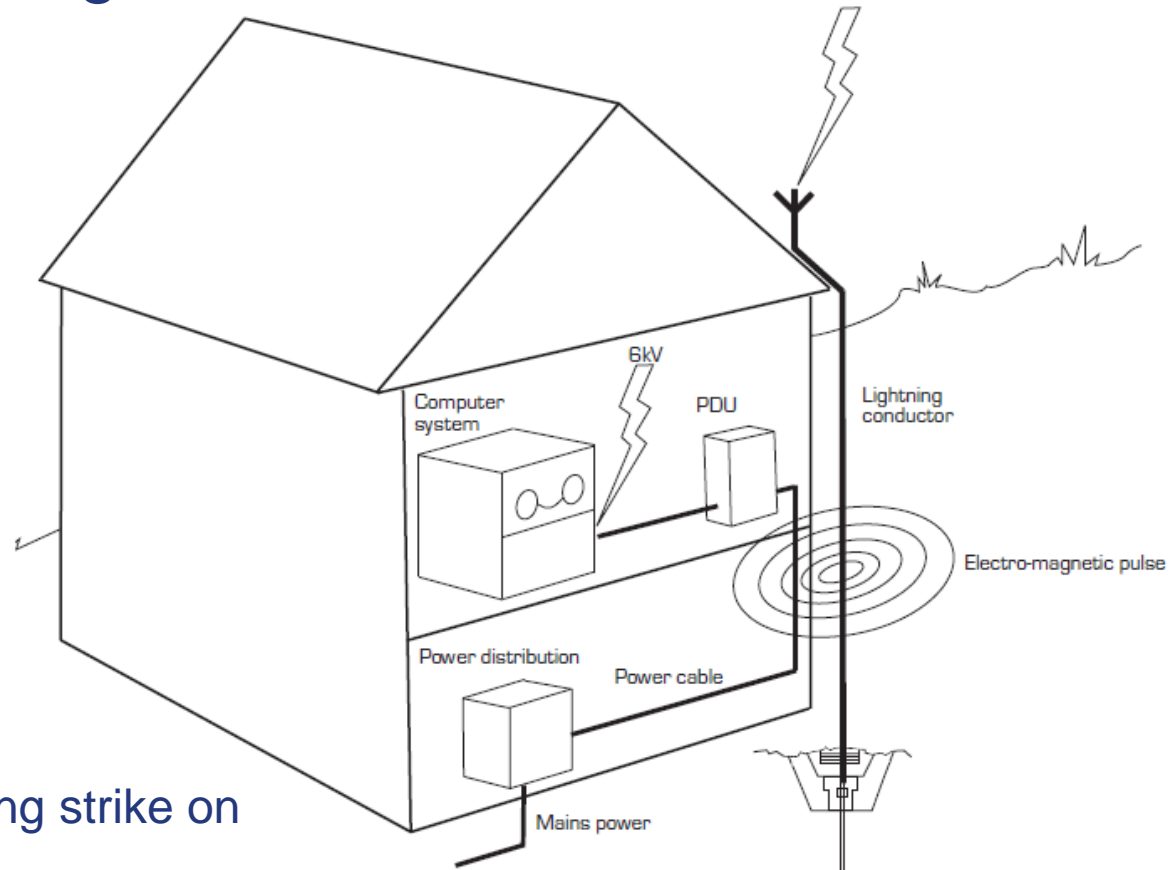
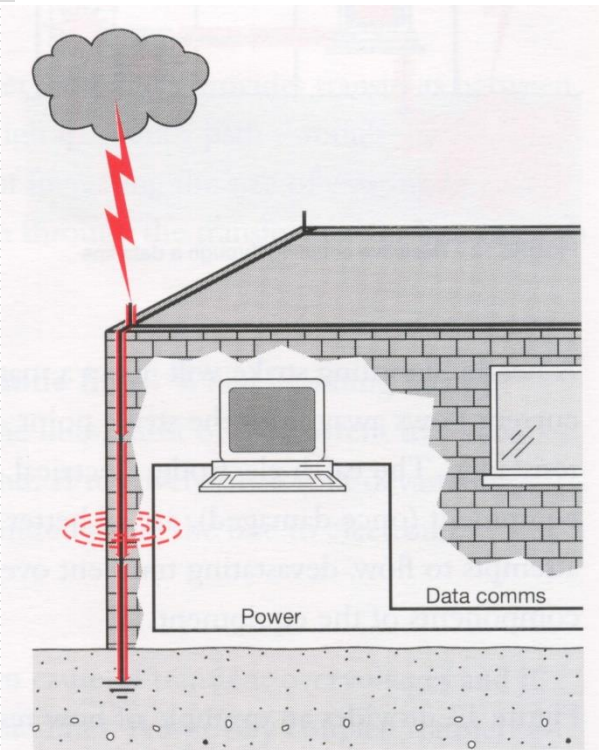

Inductive coupling from a lightning strike on an air rod

1.2 Terms & Definitions

Lightning Electromagnetic Impulse (LEMP)

- Capacitive coupling

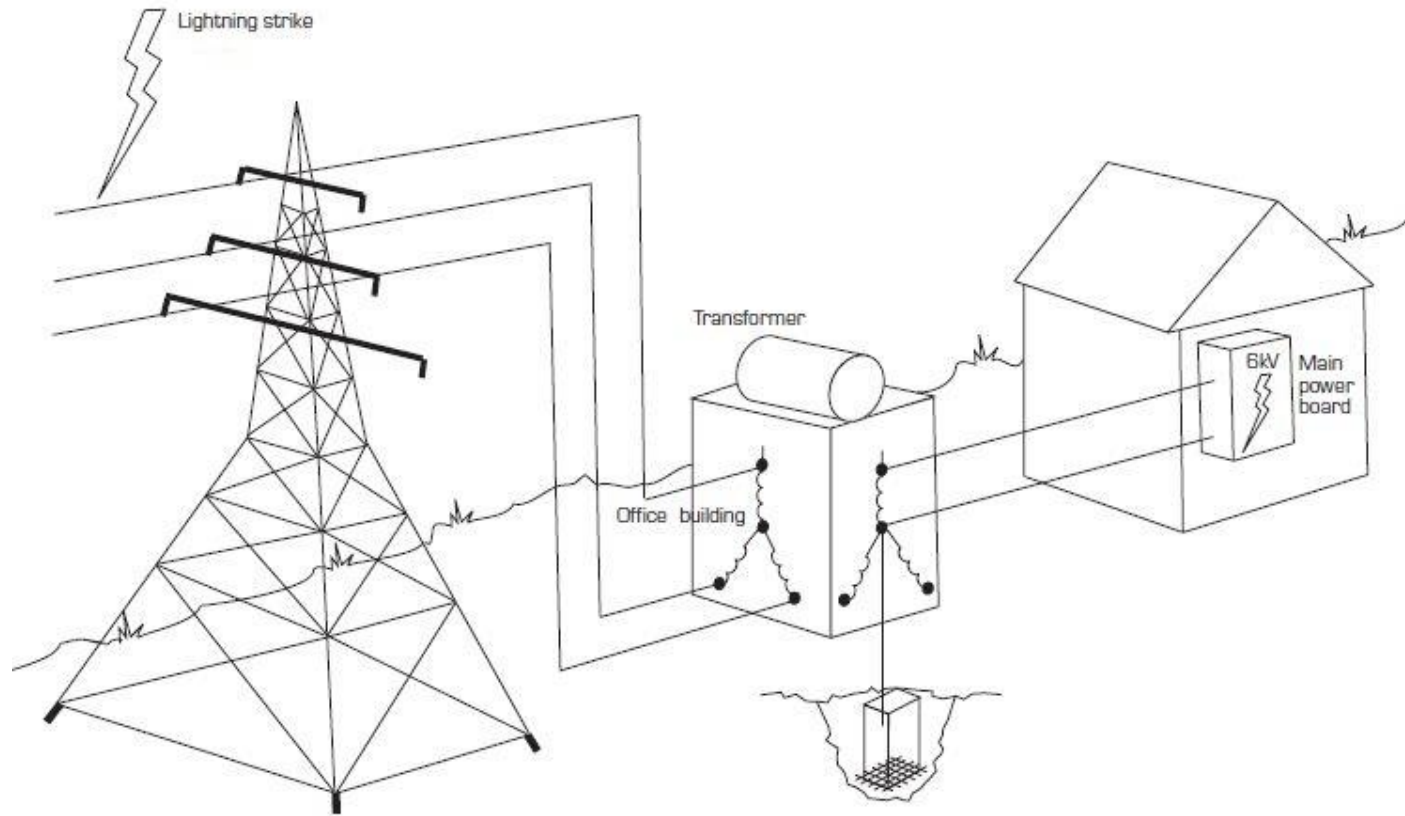

Capacitive coupling from a direct lightning strike on overhead cables

2. Introduction

2.1 General

- Malaysia is a tropical country which has recorded a high number of lightning strikes and thunderstorm activity throughout the year



2. Introduction

2.1 General

Malaysian Meteorological Department (MMD) has recorded more than 200 thunderstorm days per year (T_D) in Malaysia.



Thunderstorm Days/ Year Worldwide	
Bogor, Indonesia (1988)	322
Cerromatoso, Columbia	275-320
Malaysia	180-260
Singapore	160-220
Florida, U.S.	90-110
Colorado, U.S.	65-100
Brazil	40-200
Argentina	30-200
Japan	35-50
Most of Europe	15-40
Australia	10-70
England	5-10

2. Introduction

2.1 General

- TNBR has recorded as high as 484.4 kA (N_g) lightning impulse current in Malaysia using their Lightning Detection Network (LDN)

Top Lightning Flash Density (ground strikes/km²) Sites Worldwide	
Kamembe, Rwanda	82.7
Boende, Dem. Rep. Congo	66.3
Lusambo, Dem. Rep. Congo	52.1
Kananga, Dem. Rep. Congo	50.3
Kuala Lumpur, Malaysia	48.3
Calabar, Nigeria	47.3
Franceville, Gabon	47.1
Posadas, Argentina	42.7
Ocana, Colombia	39.9
Concepcion, Paraguay	37.0

2. Introduction

2.1 General

- Lightning Detection Network (LDN)

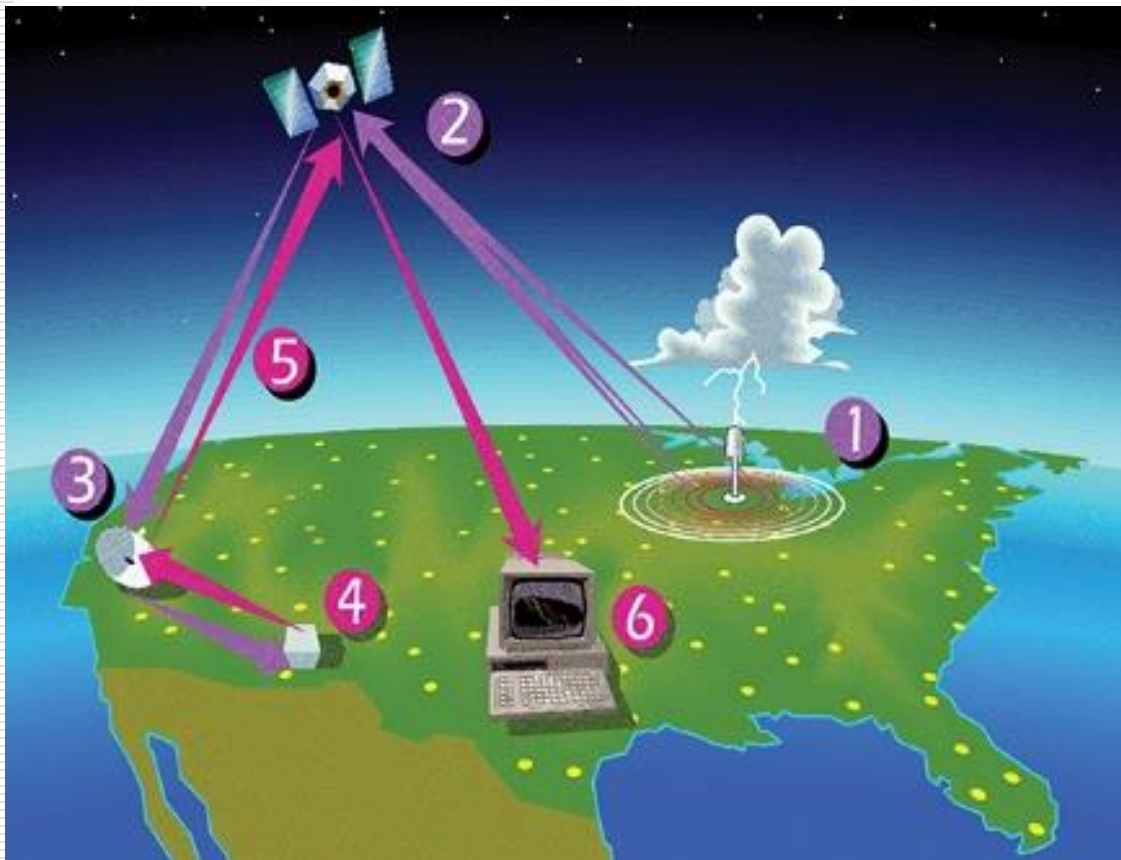

2. Introduction

2.1 General

- Lightning has become a significant threat to sensitive equipment in many countries where the most tropical countries experience heavy annual lightning occurrence density.
- Thus a highly compatible surge protective device (SPD) is crucial in order to maximize the equipment life expectancy.



2. Introduction

2.1 General

Lightning can cause different types of damage in a building, as defined in MS IEC 62305-2:

- Injuries to living beings due to touch and step voltages
- Physical damage due to mechanical, thermal and explosive effects
- **Failures of electrical and electronic systems due to electromagnetic affects.**

2. Introduction

2.2 Pattern of Lightning Activity

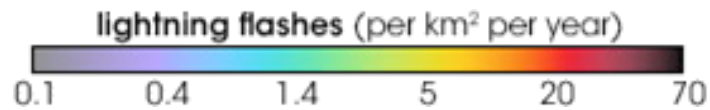
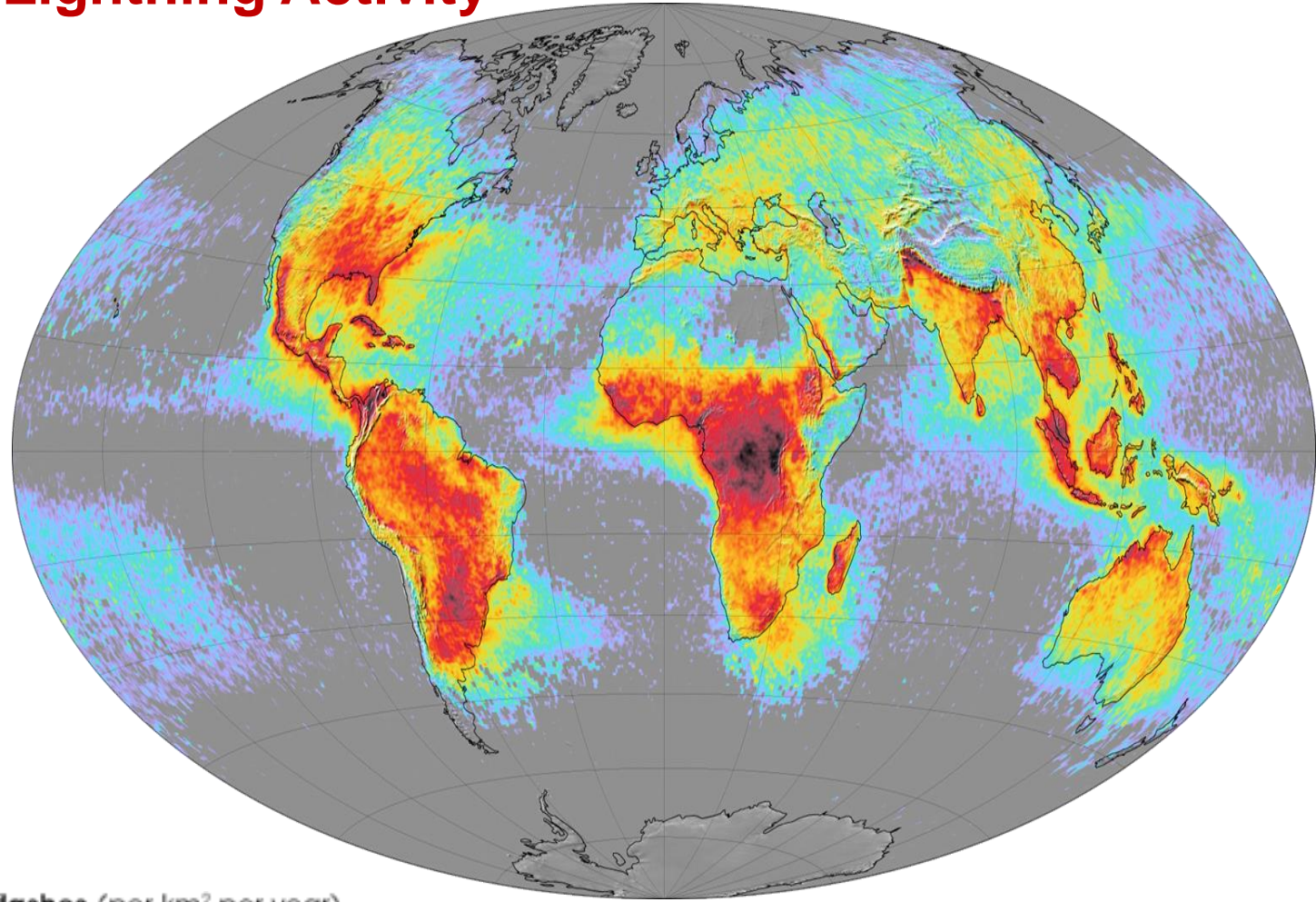

Source : Nasa

2. Introduction

2.2 Pattern of Lightning Activity

Annual Thunderstorm Day (T_D) Figures for the Year 1993 to 2002 (Hartono 2003)

Major towns/cities	10-year T_D Ave.	Max T_D	Min T_D
Langkawi	101	136	90
Alor Star	165	197	145
Butterworth	172	183	164
Bayan Lepas	202	239	185
Ipoh	165	200	135
Sitiawan	193	235	179
Subang	188	195	180
Malacca	137	165	103
Kluang	191	222	165
Senai	172	206	159
Mersing	171	188	151
Kuantan	154	173	128
Termeloh	112	156	92
Kuala Trengganu	163	184	141
Kota Baru	115	146	94
Kuala Krai	161	177	149
Kuching	184	231	151
Sri Aman	105	132	78
Sibu	103	115	85
Bintulu	133	180	102
Min	88	101	68
Labuan	147	164	112
Kota Kinabalu	139	158	113
Kudat	79	96	60
Sandakan	155	193	118
Tawau	84	124	45

2. Introduction

2.2 Pattern of Lightning Activity

Lightning Flash Density (N_g) for Peninsular Malaysia (2002 – 2006) (TNBR)

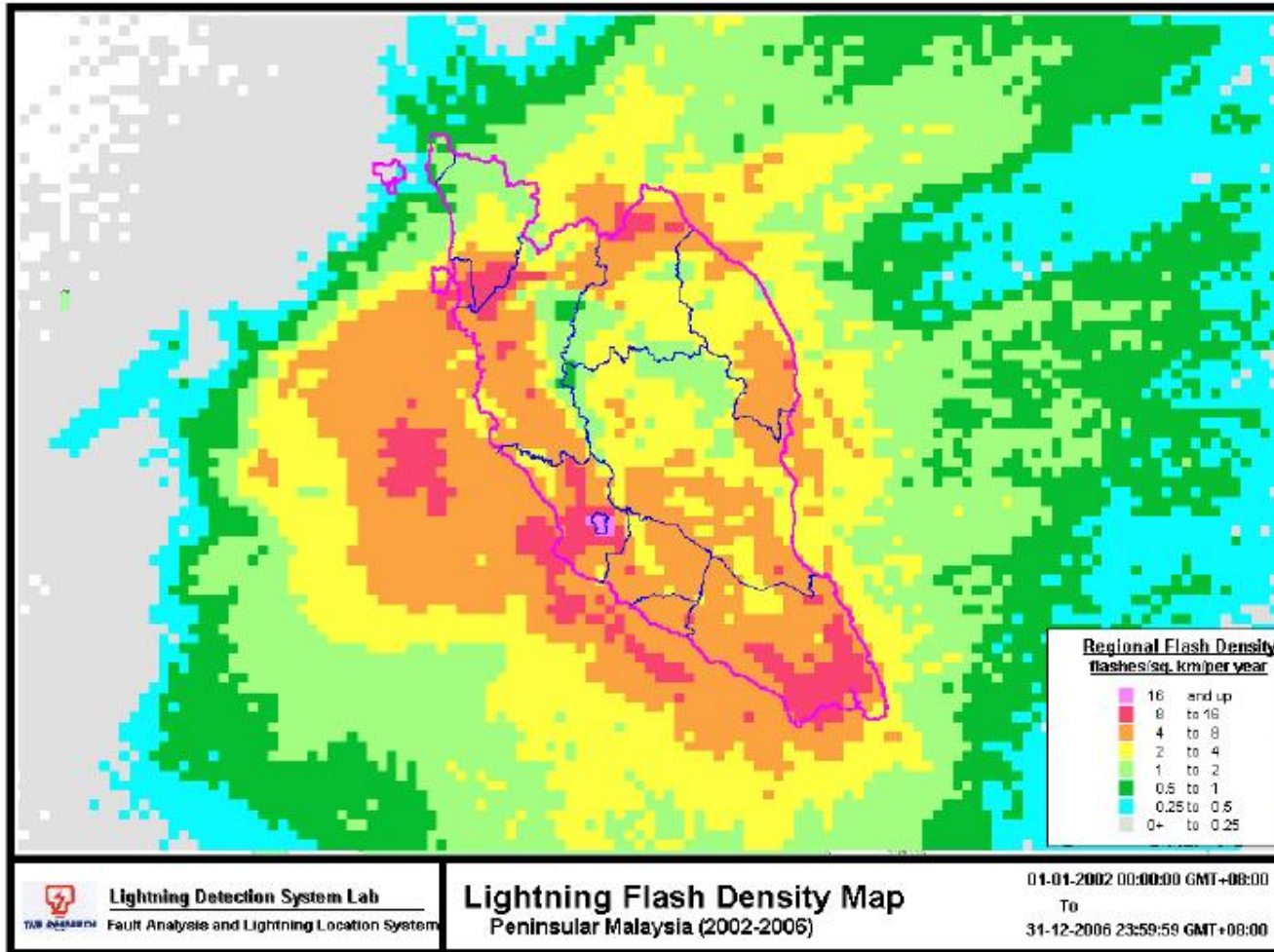

$$N_g = 0.04 T_D^{1.25}$$

2. Introduction

2.4 What is a Surge?

- A transient voltage is a short duration surge in voltage (μs)
- SPDs are used to protect, electrical systems and equipment against voltage surges and impulse currents, such as lightning and switching surges (MS IEC 61643-12)

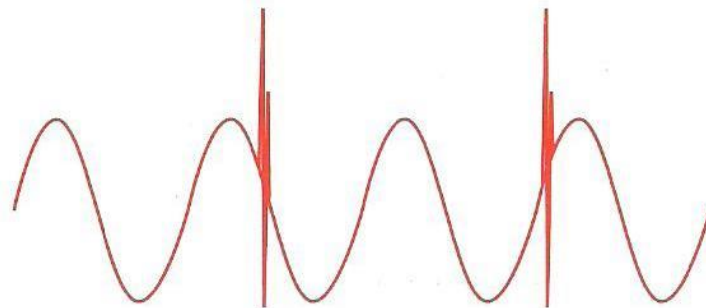

2. Introduction

2.5 Progression of Electronic Devices

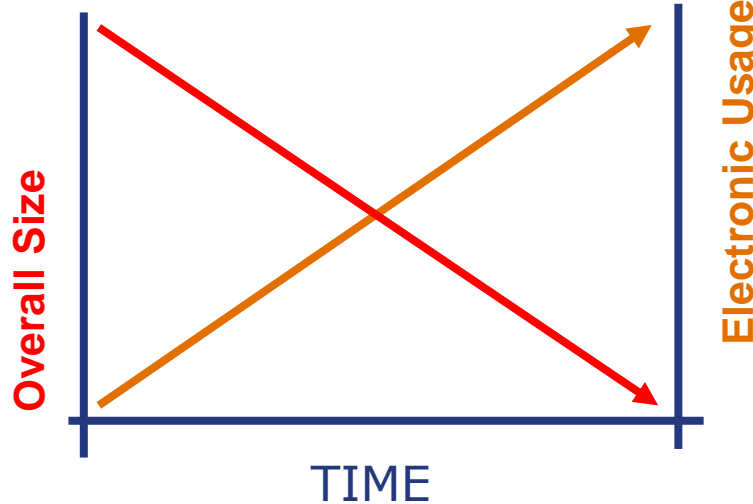

Electronic Usage



- Use of electronic equipment has increased
- Overall size of the equipment has decreased
- Smaller more compact electronic devices have become more susceptible to surge failures

3. References

3.1 Standards

- MS IEC 61643-1: Requirements and tests for power systems.
- IEC 61643-11: Requirements and test methods (cancels and replaces the IEC 61643-1)
- MS IEC 61643-12: Selection and application principles
- IEEE Std C62.41.2: Recommended Practice on Characterization of Surges in Low-Voltage (1000 V and Less) AC Power Circuits

3. References

3.1 Standards

- MS IEC 60364-5-53: Electrical installations of buildings
- IEC 61643-21: Requirements and test methods for telecommunication and signalling systems.
- IEC 61643-22: for telecommunication and signalling systems.

3. References

3.2 MS IEC 62305 & Pekeliling ST

MS IEC 62305

**Protection
against
lightning**



[Pekeliling Suruhanjaya Tenaga
Bil. 3/2011](#)

Describes the external Lightning Protection System (LPS) and the internal Lightning Protection system

Part 1 General principles

Part 2 Risk management

Part 3 Physical damage to structures and life hazard

Part 4 Electrical and electronic systems within structures

4. Terms & Definitions

- Surge protective device (SPD)
 - device that is intended to limit transient voltages and divert surge currents
- **Maximum continuous operating voltage (U_c)**
 - maximum voltage which is continuously applied to the SPD's mode of protection.

4. Terms & Definitions

- **Open Circuit Voltage, U_{oc}**
- **Short Circuit Current, I_{sc}**

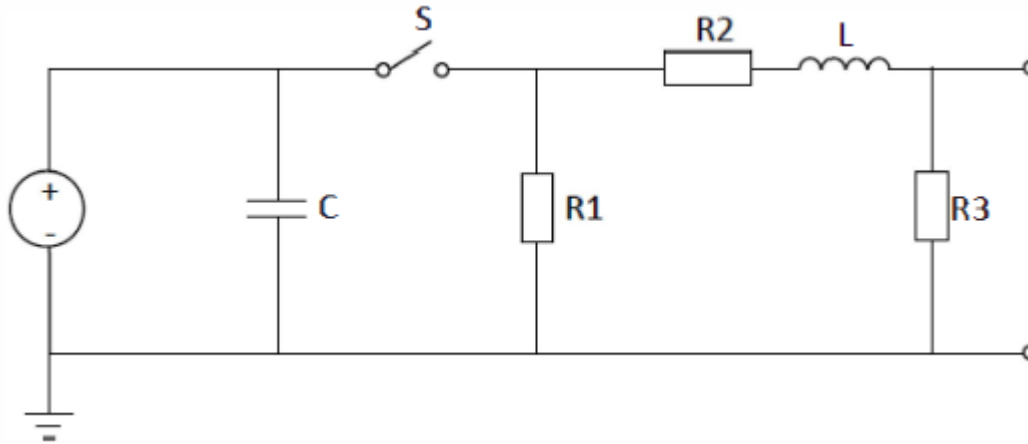

- **Maximum Discharge Current, I_{max}**
 - element that dictates the robustness of an SPD

4. Terms & Definitions

Voltage Protection Level (U_p) / Let-Through Voltage

- limiting voltage across SPD terminals, which is selected from a list of preferred values. This value is greater than the highest value of the measured limiting voltages
- In installations operating at 230/400 V, the voltage protection level (U_p) of the SPD shall not exceed 2.5 kV (IEC 60364-5-53, 534.4.4)

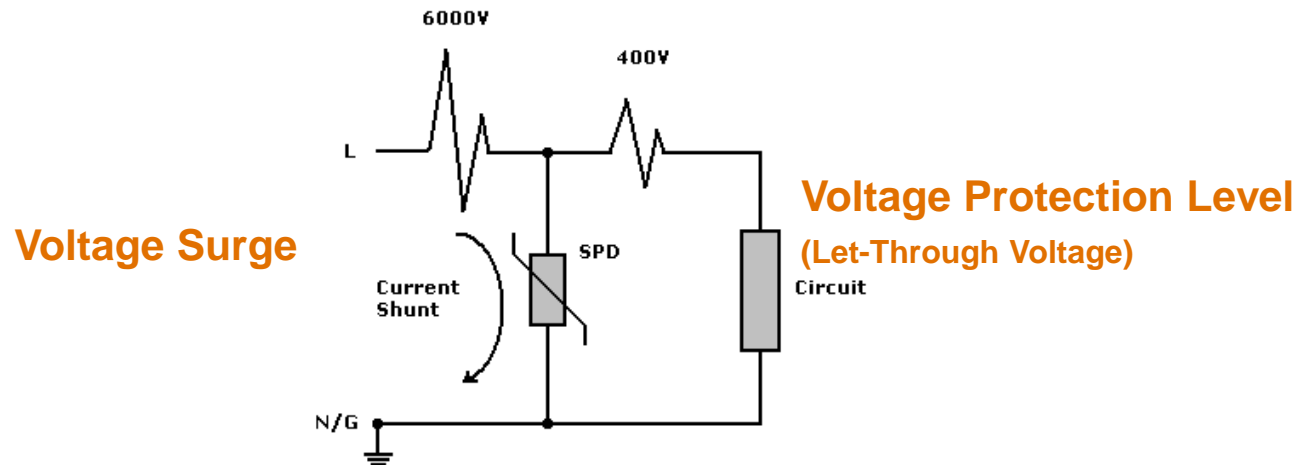

4. Terms & Definitions

Voltage Protection Level, U_p

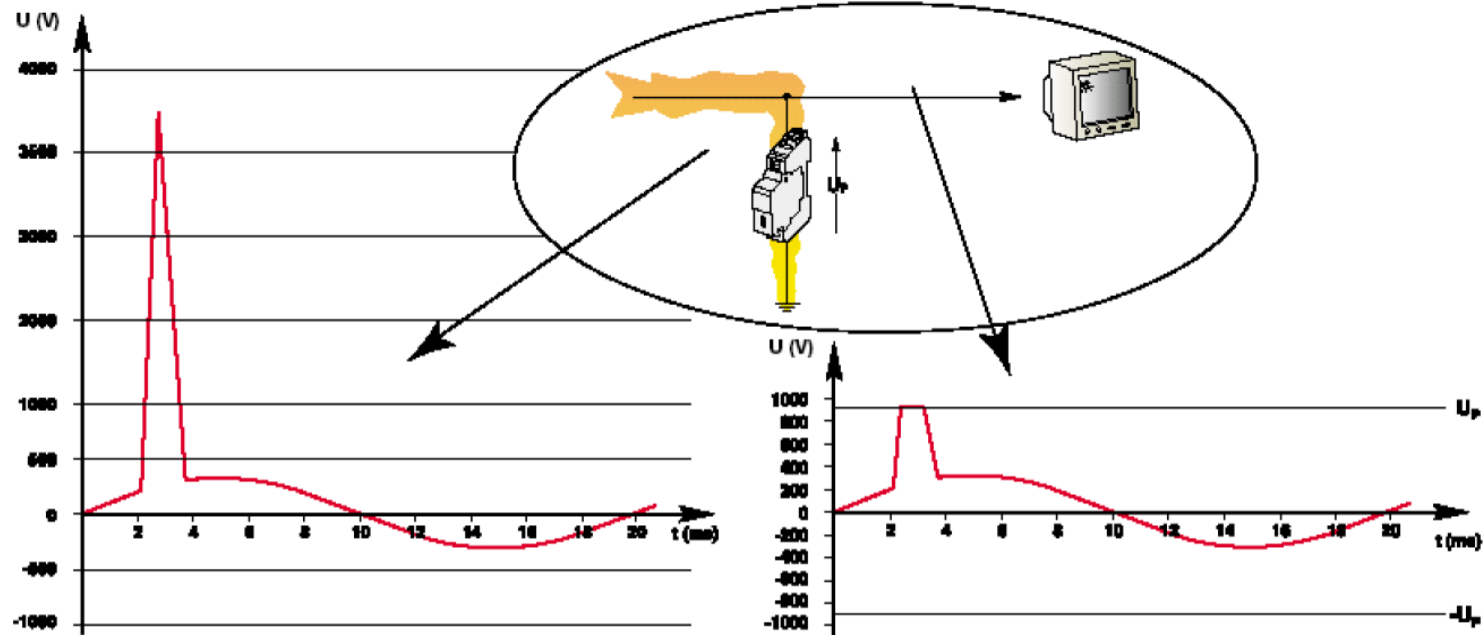

4. Terms & Definitions

- Continuous operating current (I_c)
 - current flowing through each mode of protection of the SPD when energized at the maximum continuous operating voltage (U_c) for each mode

4. Terms & Definitions

- *Continuous operating current (I_c) shall not cause any personnel safety hazards (indirect contact, etc.) or disturbance to other equipment (for example, RCD) (sub-clause 6.2.4.1, MS IEC 61643-12).*

5. Systems & Equipment to be Protected

5.1 Causes of Surge

- There are two general causes of surge
 - Natural causes (lightning)
 - Other causes due to equipment (switching):
 - Utility switching (e.g. TNB)
 - Facility equipment due to switching in your facility (e.g. air-conds, lifts), your neighbours facility



5. Systems & Equipment to be Protected

5.1.1 Natural Causes (Lightning)

direct lightning strike on an air terminal

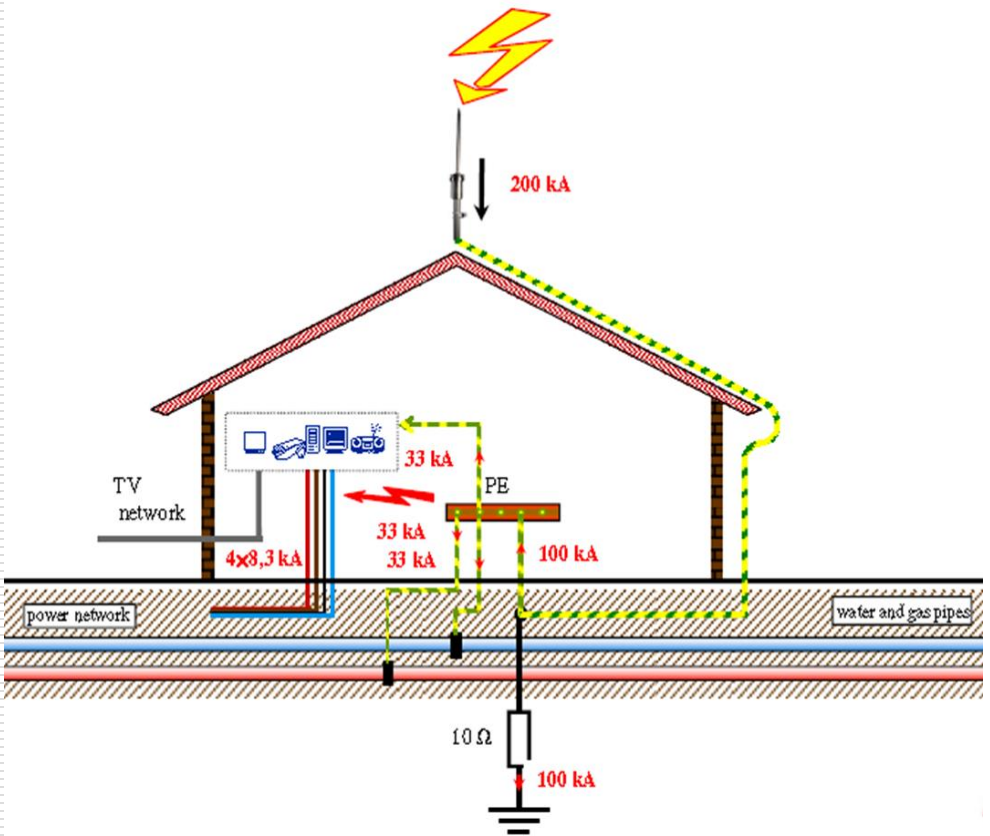

direct lightning strike to a tree



direct lightning strike on the overhead lines

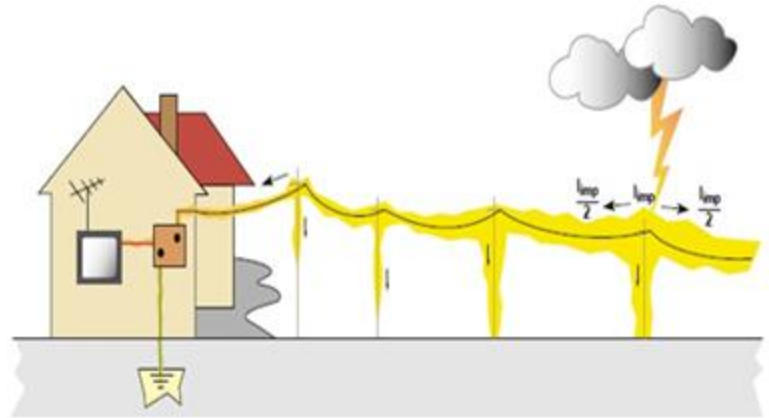

5. Systems & Equipment to be Protected

5.1.1 Natural Causes (Lightning)

Direct Lightning Strike On An Air Terminal



5. Systems & Equipment to be Protected

5.1.1 Natural Causes (Lightning)

Direct Lightning Strike to a Tree



5. Systems & Equipment to be Protected

5.1.1 Natural Causes (Lightning)

Direct Lightning Strike to a Tree



5. Systems & Equipment to be Protected

5.1.1 Natural Causes (Lightning)

Direct Lightning Strike On The Overhead Lines



5. Systems & Equipment to be Protected

5.1.1 Natural Causes (Lightning)

Direct Lightning Strike to the Ground



5. Systems & Equipment to be Protected

5.1.1 Natural Causes (Lightning)

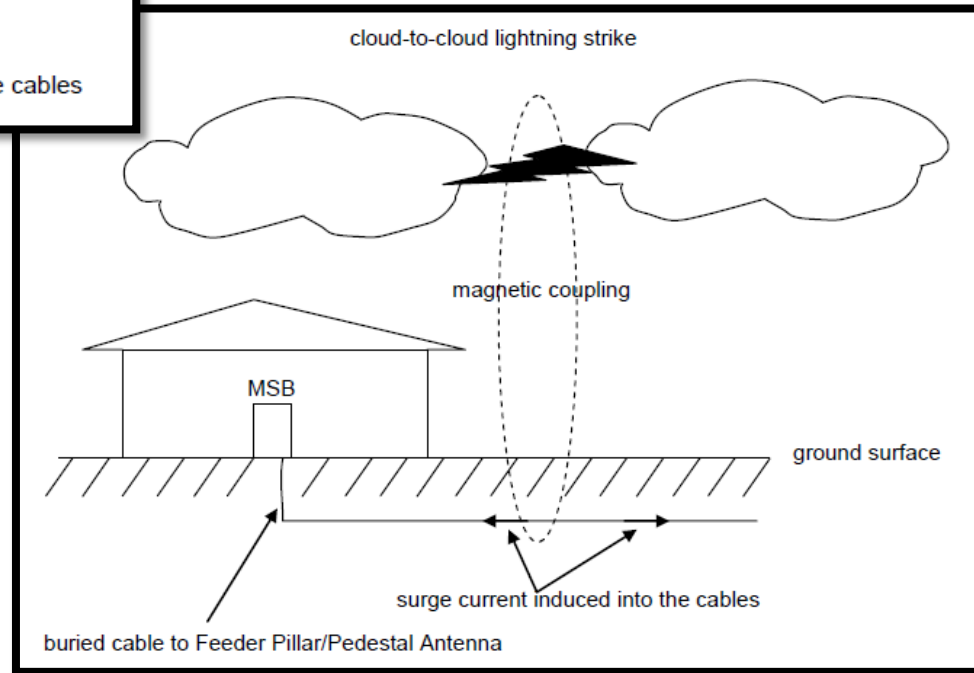
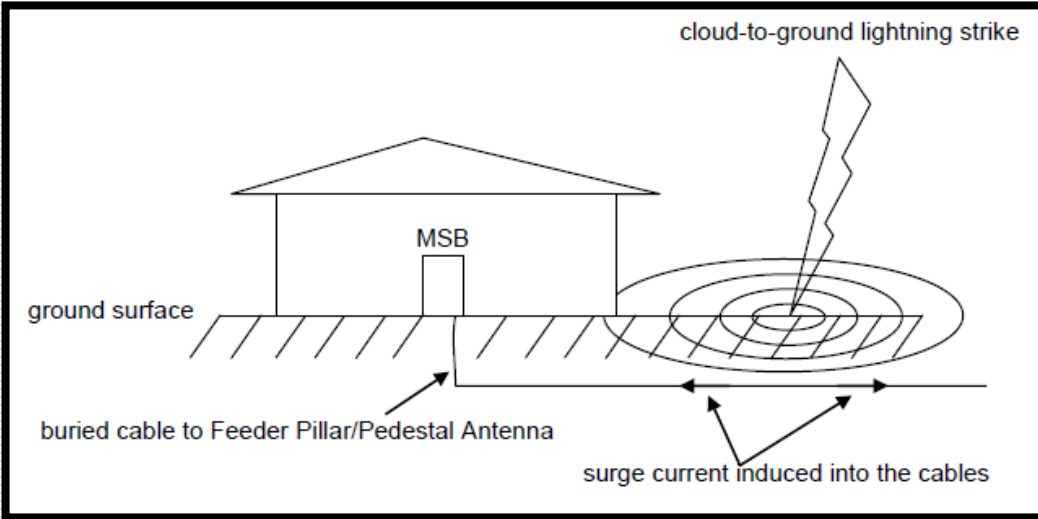

5. Systems & Equipment to be Protected

5.1.1 Natural Causes (Lightning)

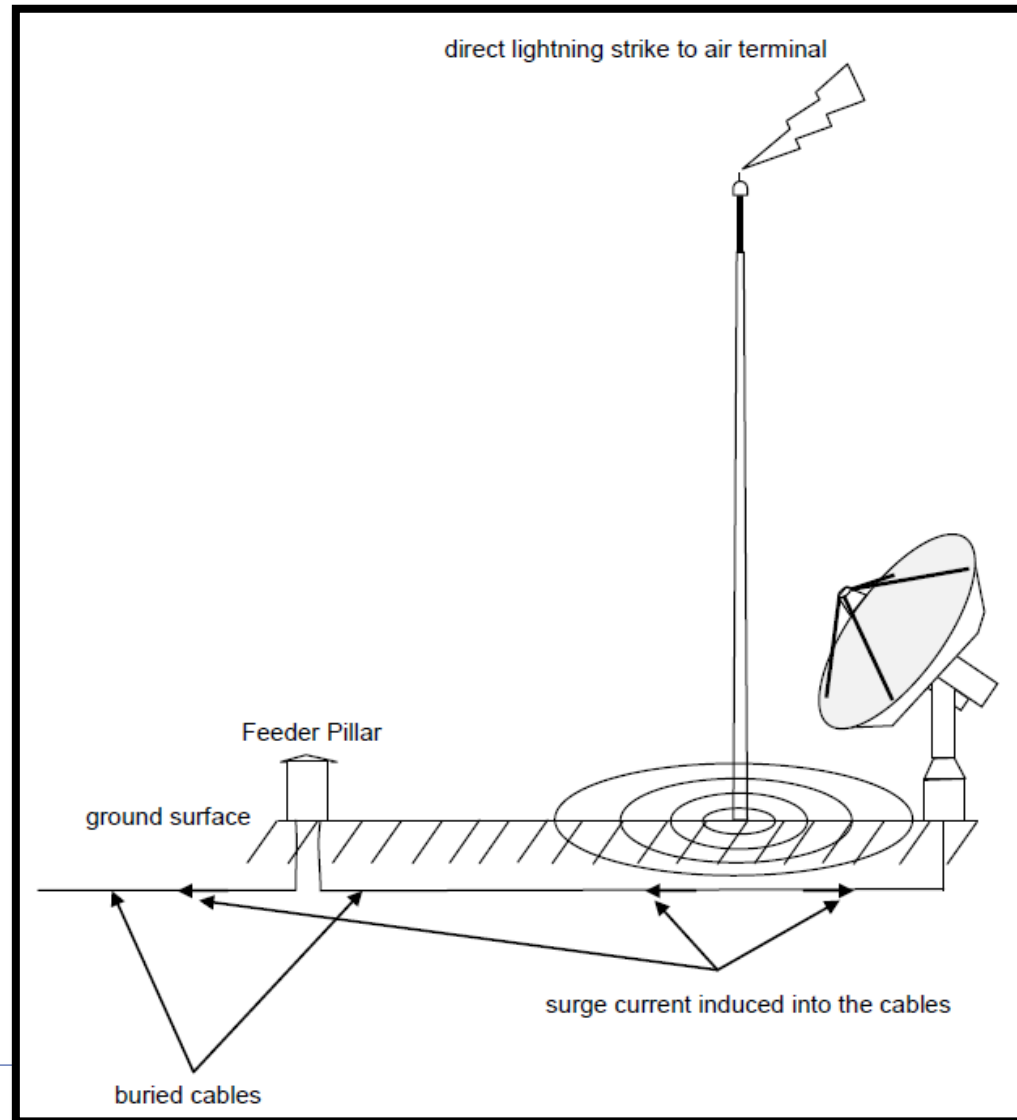

5. Systems & Equipment to be Protected

5.1.1 Natural Causes (Lightning)



Initial direct or indirect strike



Travels through power lines or ground



Enters your facility

- Direct lightning strikes
 - Can be the most damaging
- Indirect lightning strikes
 - Indirect lightning strikes up to 4 km away can still affect your facility

5. Systems & Equipment to be Protected

5.1.1 Natural Causes (Lightning)

Exterior Wiring

- Many buildings have some form of exterior wiring
- Electric gates, outdoor lighting and CCTVs are just a few examples of outdoor electrical devices in use today
- Lightning strike in close proximity to underground wiring can cause a voltage surge which has a direct path to the building distribution system

5. Systems & Equipment to be Protected

5.1.2 Causes due to Equipment Switching

Type 1: Utility Switching



Utility Grid Switching



Travels through power lines or ground



Enters your facility

Type 2: Facility generated

Generated from within your facility



Switching of large transformers, motors, and other inductive loads can generate spikes or transient impulses

5.2 Harmful Effects of Transient Surges

- The most common failures produced by transients within electronic devices are:
 - **Disruptive effects** – Encountered when a voltage transient enters an electronic component and the component then interprets the transient as a valid logic command, resulting in system lock-up, malfunctions, faulty output or corrupted files
 - **Dissipative effects** – Associated with short duration repetitive energy level surges, resulting in long-term degradation of the device
 - **Destructive effects** – Associated with high level energy surges, resulting in immediate equipment failure

5.3 Equipment to be Protected

Required minimum Impulse Withstand Voltage (U_w or U_{imp}) for a 230 V system (MS IEC 60364-4-44)

Category	Required min. impulse withstand voltage	Typical location/ equipment
IV	≥ 6 kV	Electricity meter, motors, MCCB
III	≥ 4 kV	MSB, SSB, ACB, MCCB, isolators, cables, busbar, junction boxes, ELR
II	≥ 2.5 kV	DB, MCB
I	≥ 1.5 kV	Socket outlet, sensitive electronic equipment, computers, TV

It should be noted that some equipment requires a particularly low protection level. E.g. medical equipment, UPSs (with very sensitive electronics) $U_w < 0.5$ kV. The protection level U_p of SPD is chosen according to the equipment to be protected.

6. Surge Protective Devices (SPDs)

6.1 Classification of SPDs

(a) *One-port SPD:*

SPD connected in shunt (parallel) with the circuit to be protected. A one port device may have separate input and output terminals without a specific series impedance between these terminals.

(b) *Two-port SPD:*

SPD with two sets of terminals, input and output. A specific series impedance is inserted between these terminals. This protection is not effective.

6.2 Typical Design

- Voltage limiting (clamping type)
 - MOVs
- Voltage switching (crowbar type)
 - Spark gaps or gas discharge tubes (GDTs)
- Combination
 - Voltage switching components and voltage limiting components

6.2 Typical Design

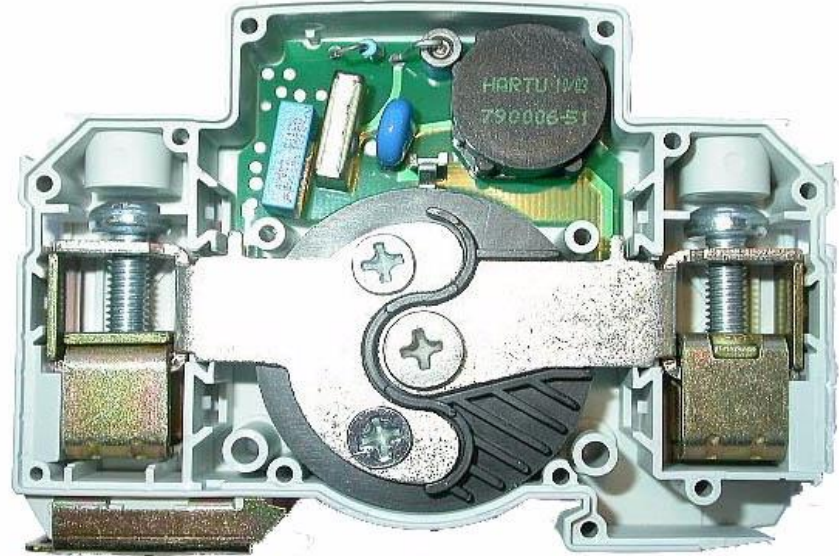

6.2 Typical Design



6.2 Typical Design

- When the MOVs are used, the SPDs shall be provided with integrated thermal protection to avoid thermal runaway due to degradation of MOVs.
- Thermal fuse uses the heat of the failing MOV to cause a disconnection to occur. This is usually accomplished by allowing a soldered connection to melt and spring open

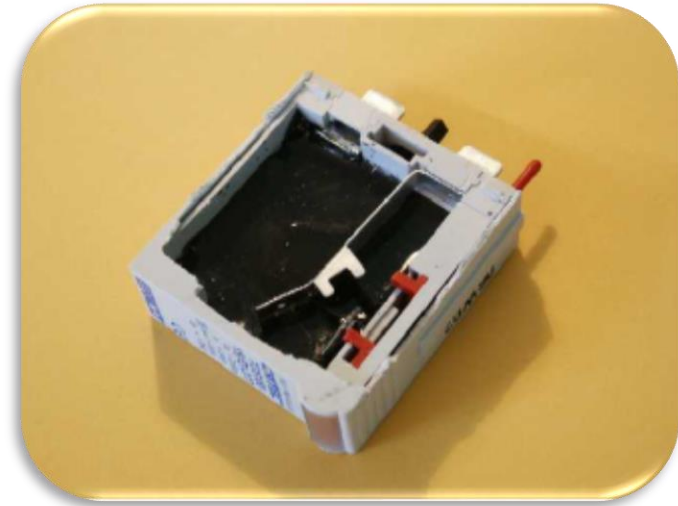

6.3 Characteristics of SPDs

Surge Waveform (Combination Waveform)

Characteristic of standardised surge voltage, 1.2/50 μ s

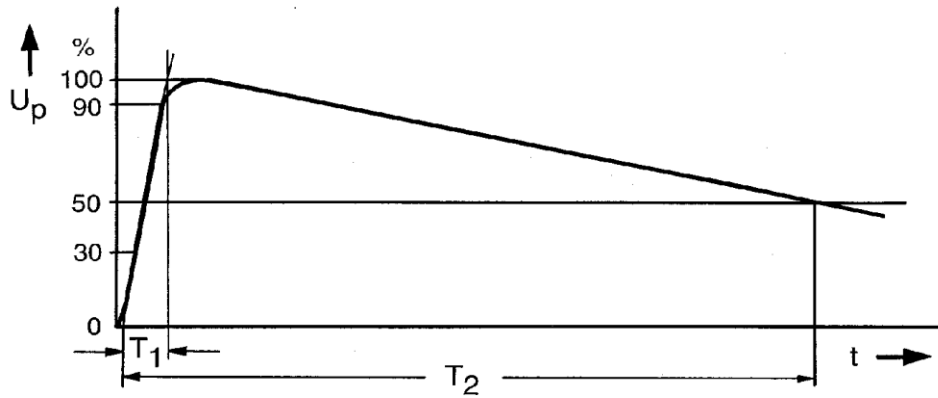

Characteristic of standardised surge current, 8/20 μ s

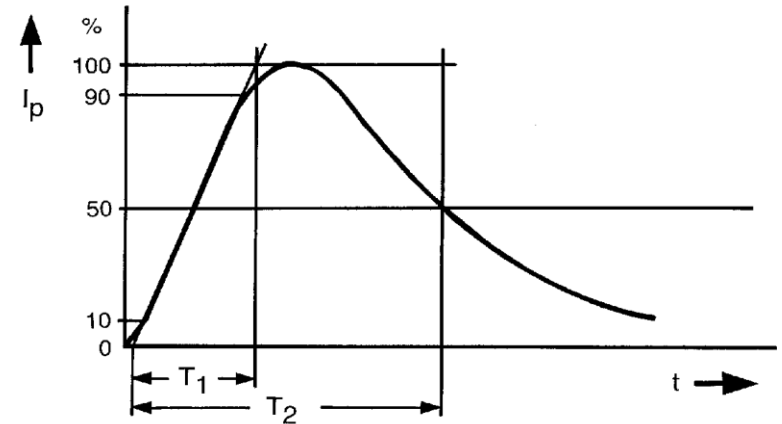

T_1 Front time

T_2 Tail time

6.3 Characteristics of SPDs

- Impulse voltage/current is defined by its front time T_1 , tail time T_2 and peak value of the voltage/current
- Example
1.2/50 μs , 20 kV represents an impulse voltage with front time 1.2 μs , tail time 50 μs and peak value of 20 kV

6.3 Characteristics of SPDs

Standard Impulse Waveshape

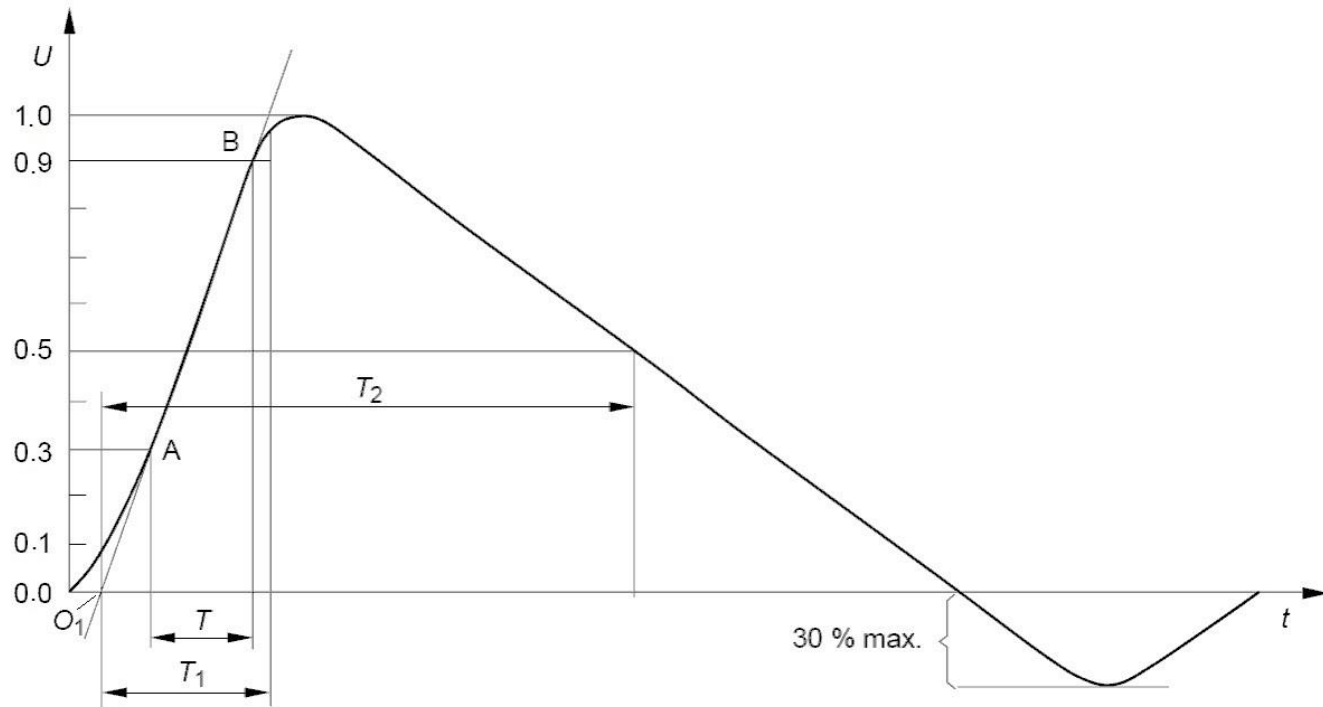

- T is the time taken for voltage to rise from 10 to 90% of the peak value
- In cases where the value for 10% is difficult to be determined, T can also be defined with respect to 30%

6.3 Characteristics of SPDs

Standard Impulse Waveshape

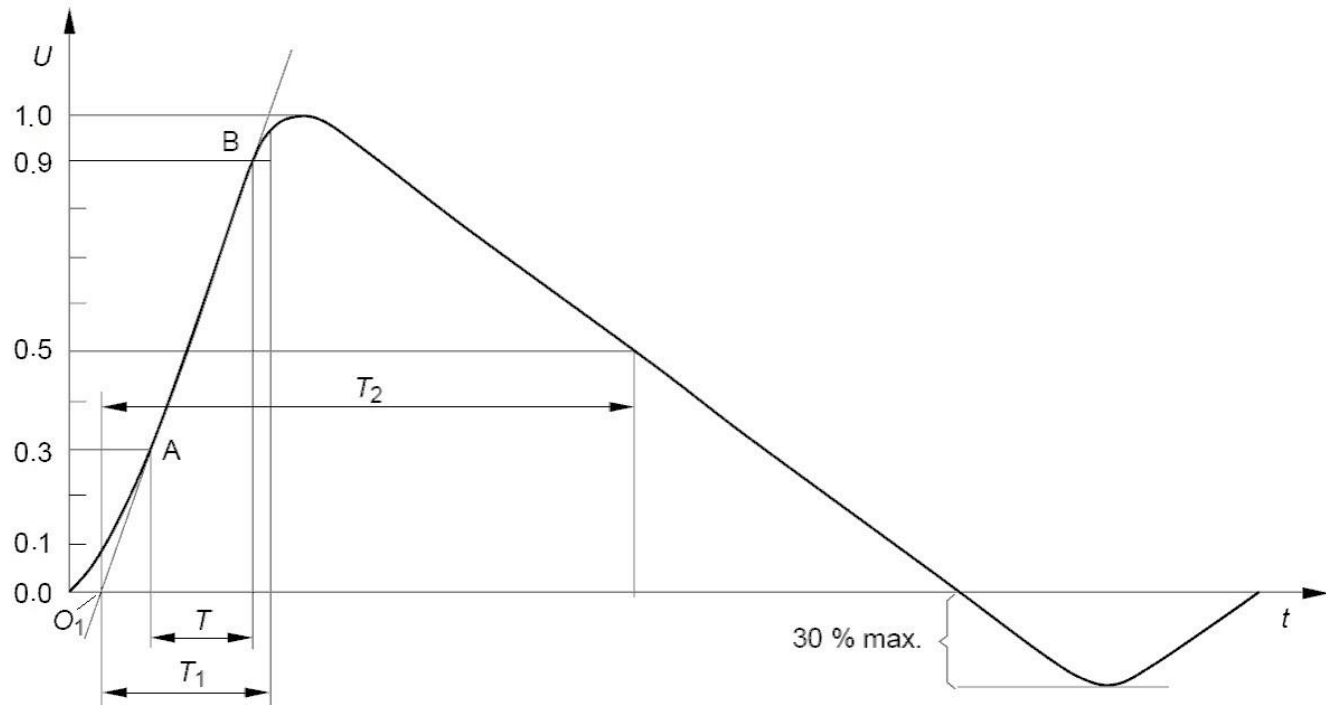

- Front time T_1 is the time with respect to the extrapolated line
- T_2 is the time taken for the impulse voltage to fall to its 50% magnitude after reaching the peak value

6.3 Characteristics of SPDs

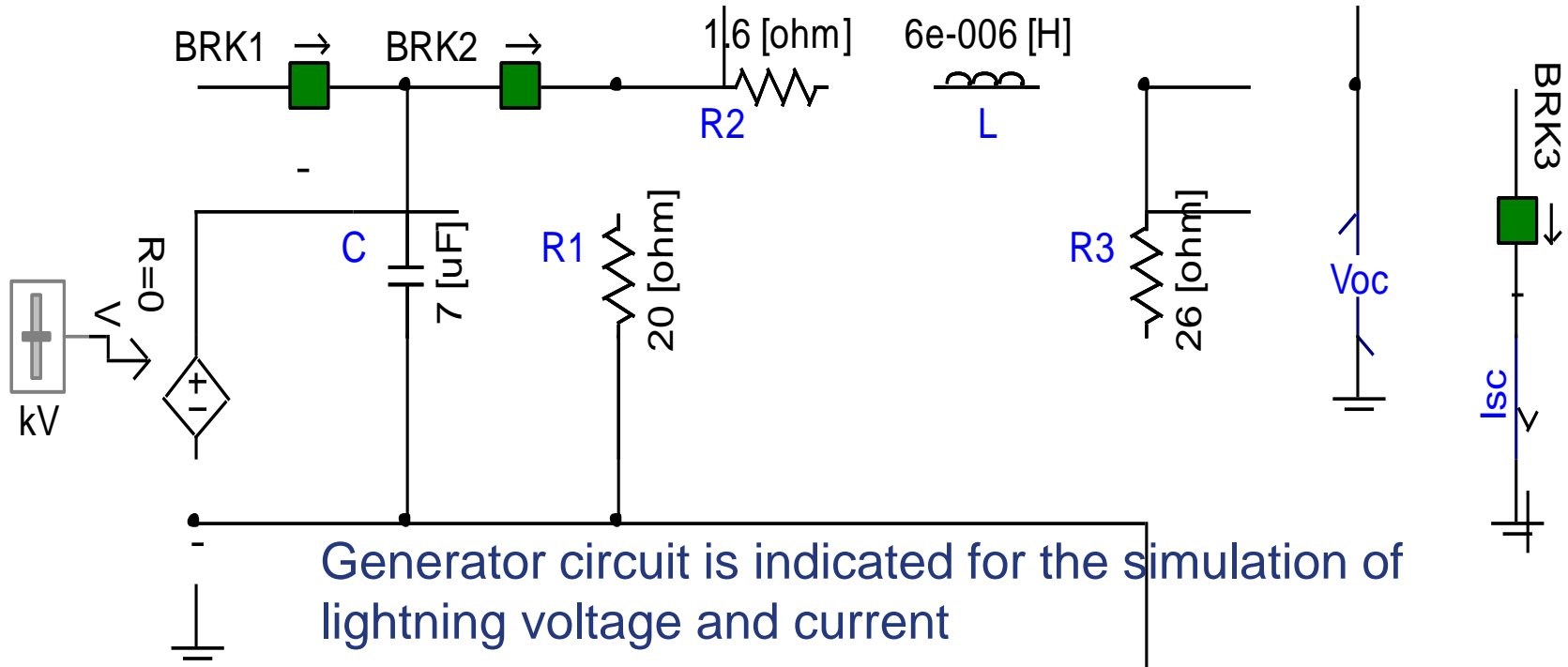

- Capacitor C is slowly charged from source until the HV switch BRK1 is opened with very short ignition time.
- Once the BRK1 is opened, the BRK2 is closed, R2 will damp the circuit to allow the front of the wave to reach peak in the desired time

6.3 Characteristics of SPDs

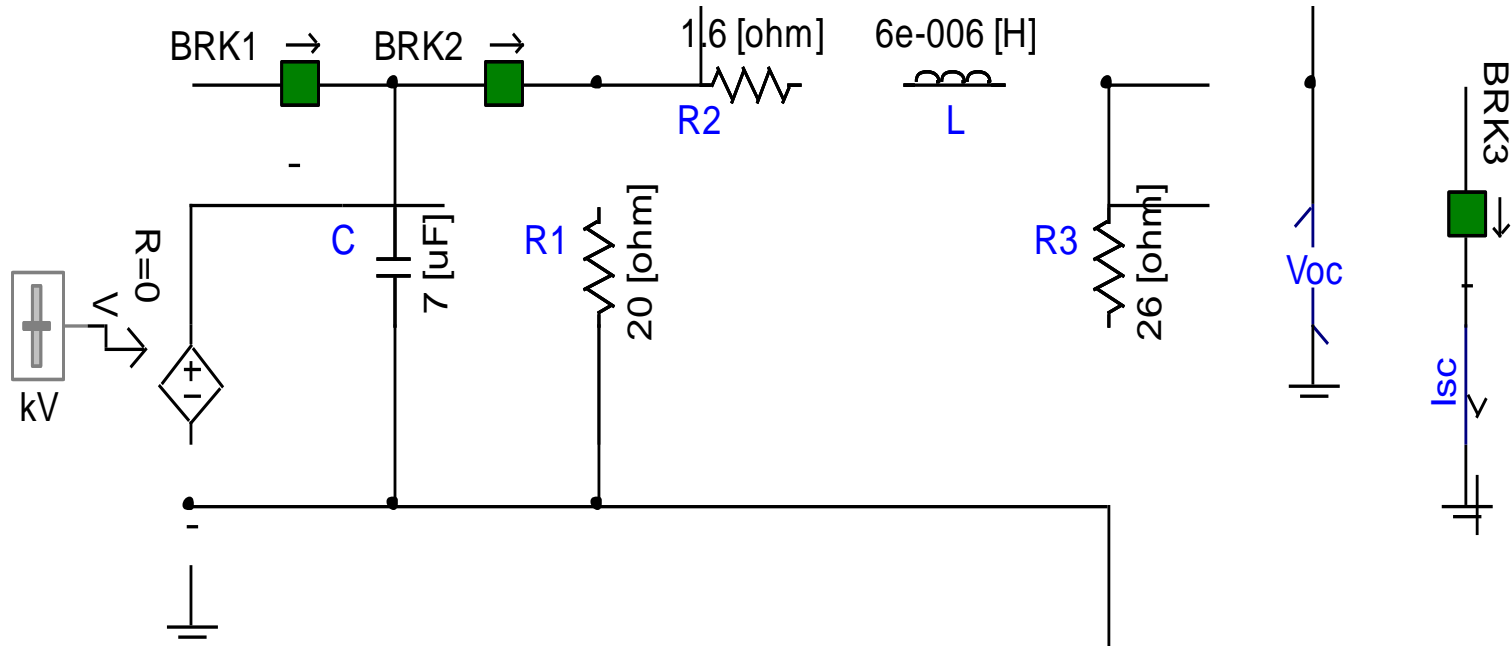

- R1 will discharge the capacitor C, thus control the tail of the wave shape to the half-voltage level (50% magnitude)
- R3 represents the full load
- Inductor L allows the short circuit current waveform to reach peak current in the desired time.
- **A negative or positive waveform can be achieved by changing the polarity of DC source as positive or negative.**

7. Application of SPDs

7.1 Modes of Protection

- A typical 3 \emptyset configuration of the electrical distribution includes three phase wire, one neutral wire and earthed at the service entrance of an installation.
- The possible protection modes include three line-to-neutral modes, three line-to-earth modes and one neutral-to-earth mode

7.1 Modes of Protection

- Mode of protection shall be each L-N, each L-E and N-E.
- There is no benefit in connecting the SPDs from L-L. Commercial gimmick.

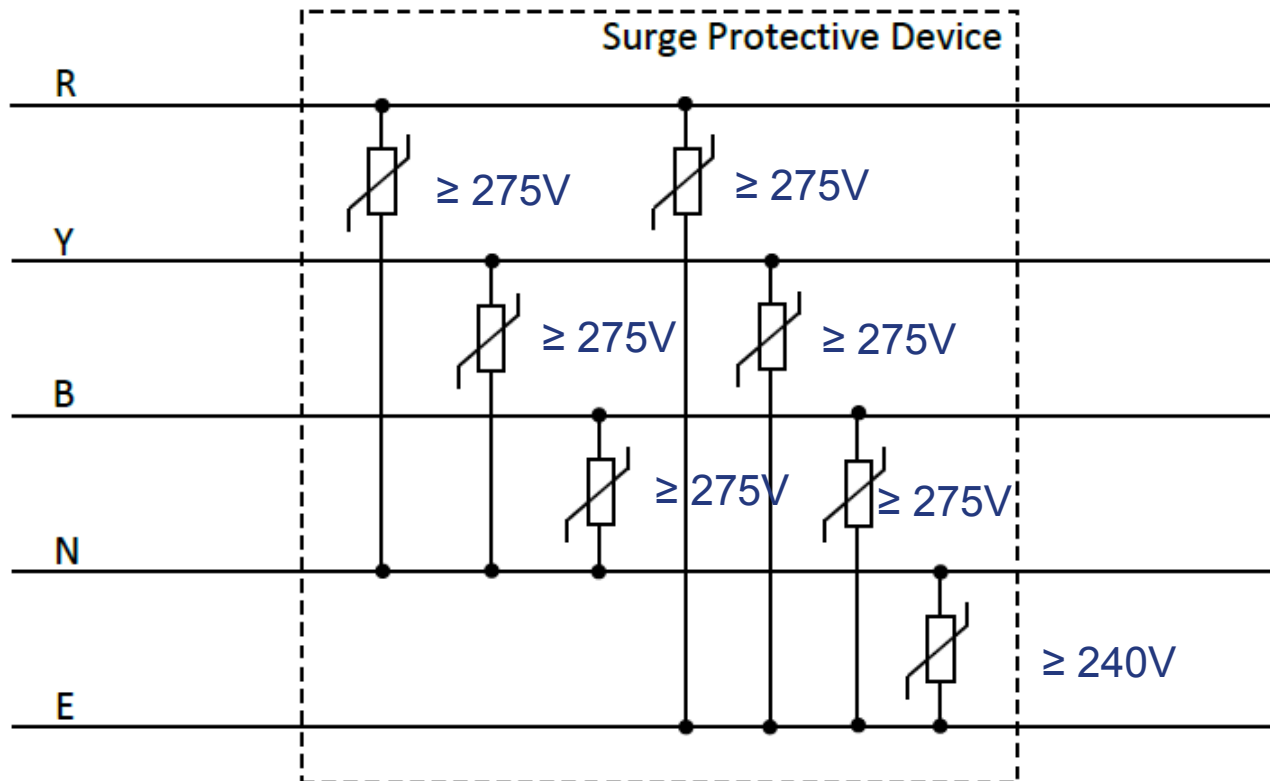

7.1 Modes of Protection

Common mode

- Overvoltages occur between the live conductors and earth (e.g. phase/earth or neutral/earth)

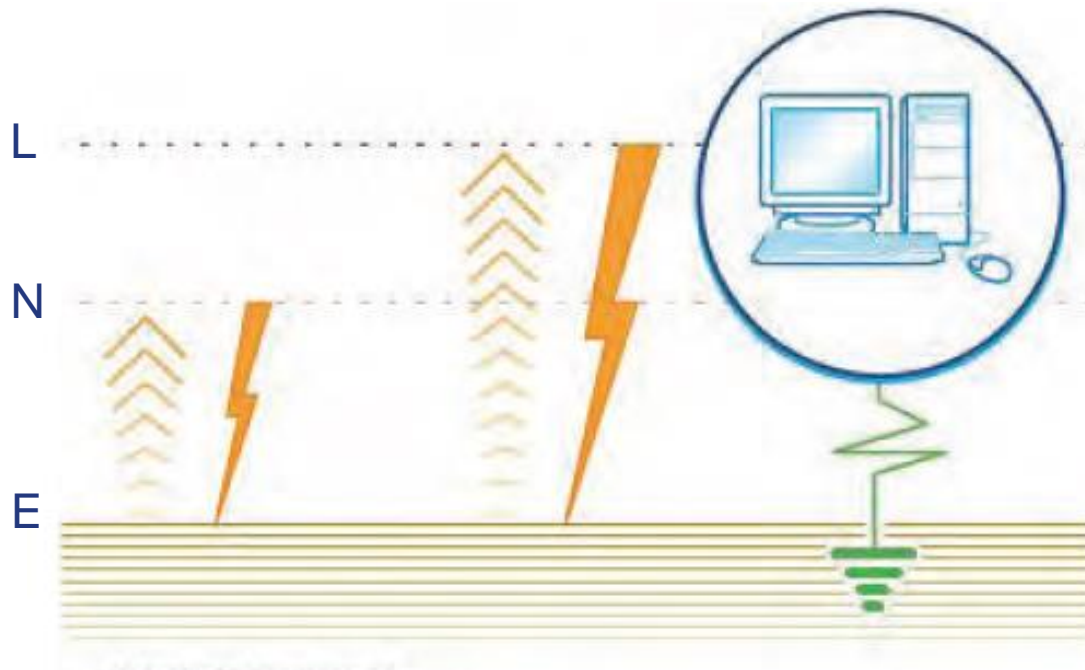

7.1 Modes of Protection

Differential mode

- Overvoltages in differential mode circulate between the live phase/phase or phase/neutral conductors. They can cause damage to any equipment connected to the electrical network, particularly sensitive equipment.

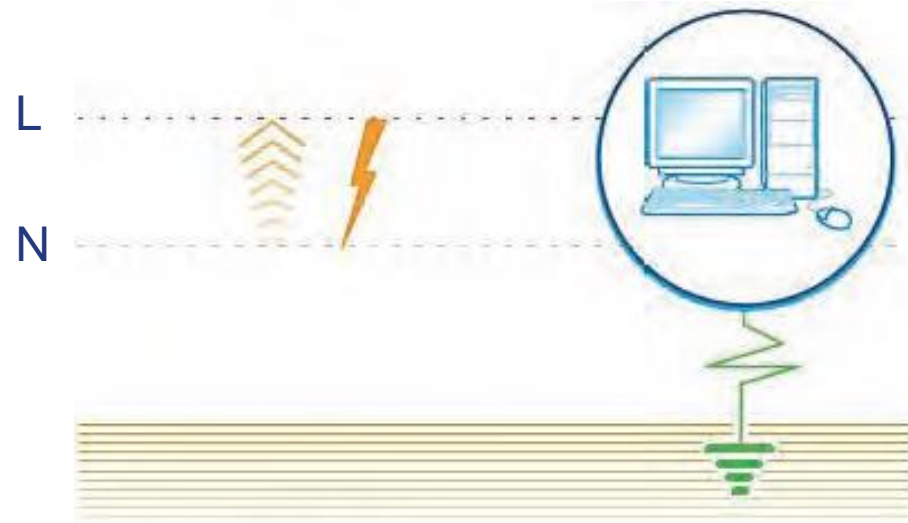

7.1 Mode of protection

- Connection type (3+1 configuration) for a three-phase system with neutral (IEC 60364-5-53)

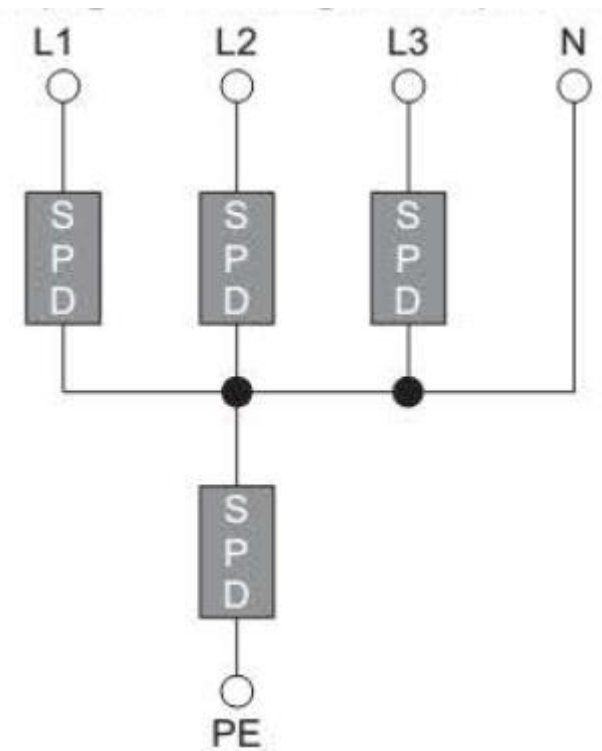
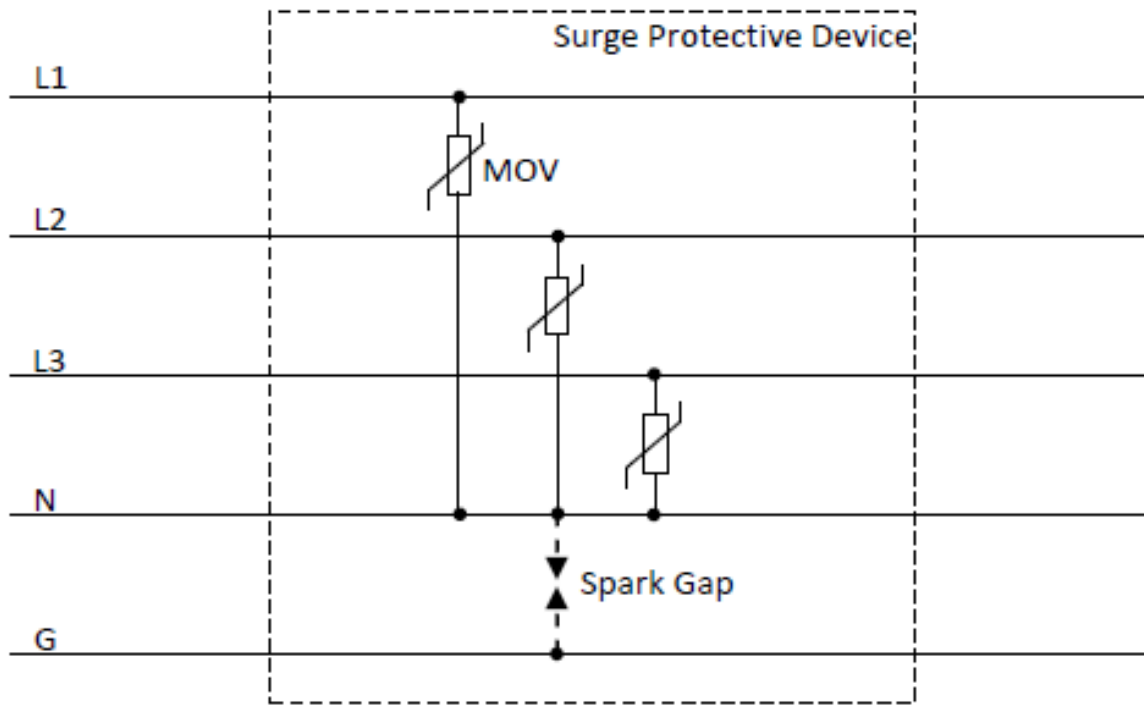

7.1 Mode of Protection

- Installation of SPDs in TT systems (IEC 60364-5-53)

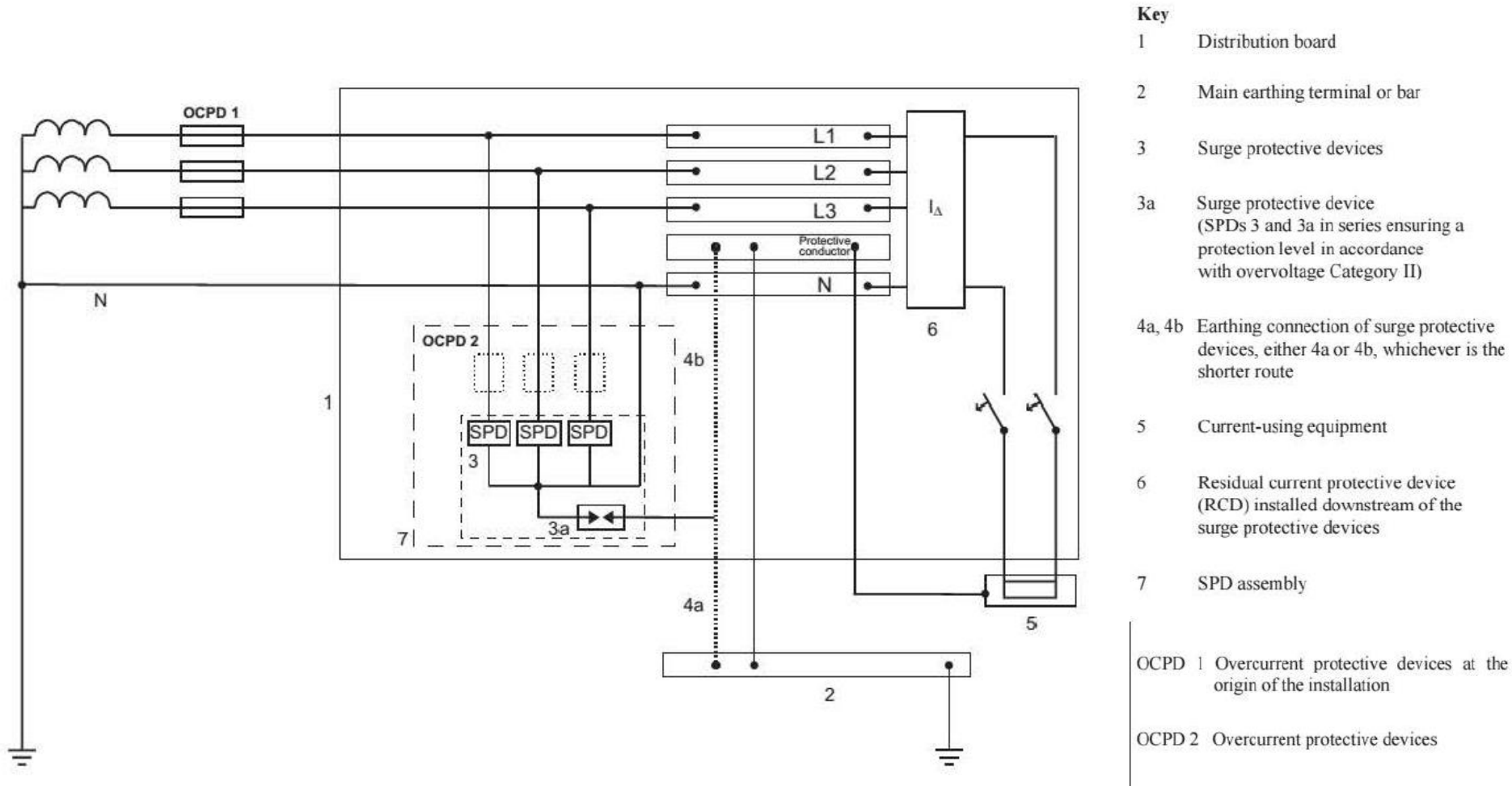

7.2 SPD Failure Modes

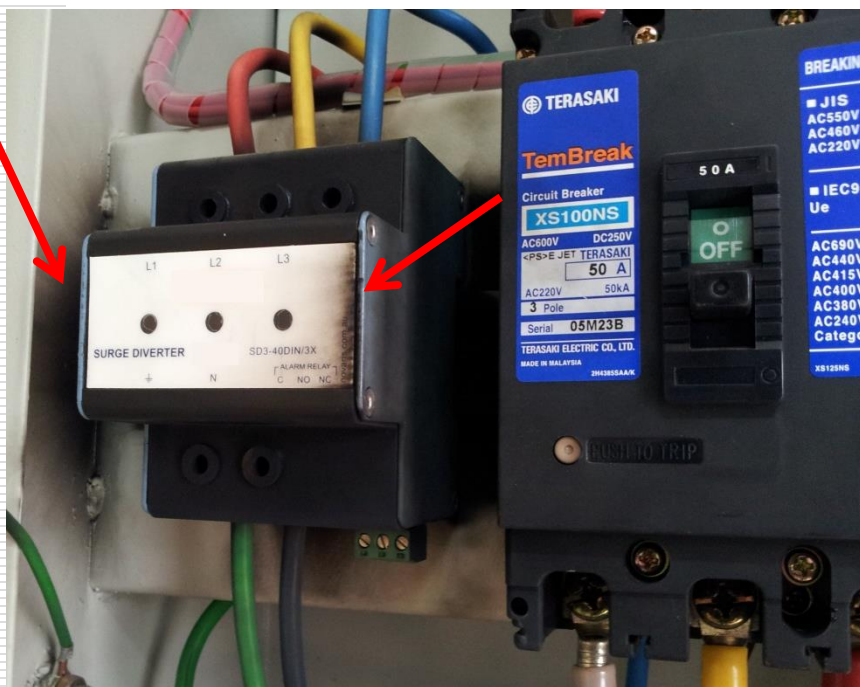

SPD failures are typically not due to a surge event. The most common reason for SPD failure is sustained temporary overvoltage (TOV) on an MOV. A TOV can result from utility/facility faults or loss of the neutral on 3-phase, 4-wire systems. These occurrences degrade the MOV gradually and changing its resistance from megaohms to milliohms

7.2 SPD Failure Modes

Phase-to-earth fault conditions

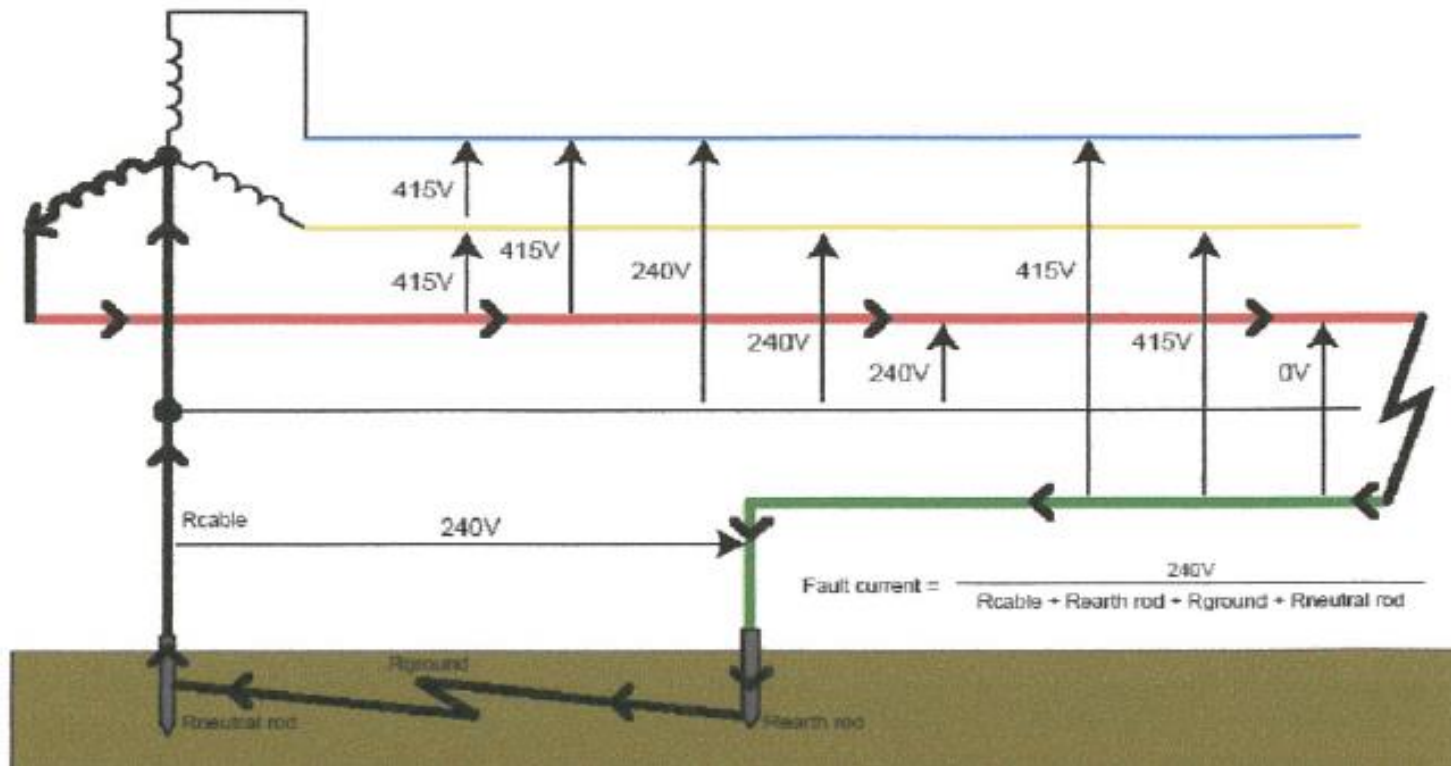

7.2 SPD Failure Modes

Phase-to-neutral fault conditions

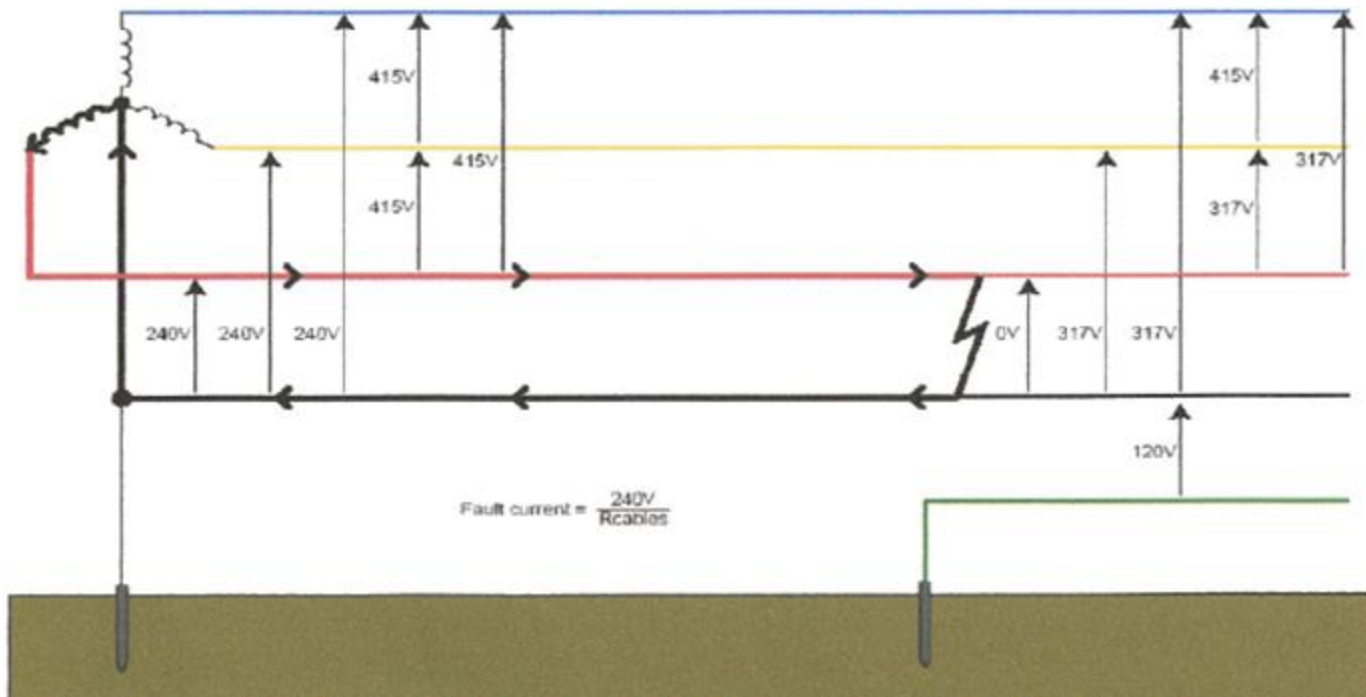

7.2 SPD Failure Modes

Broken neutral fault conditions

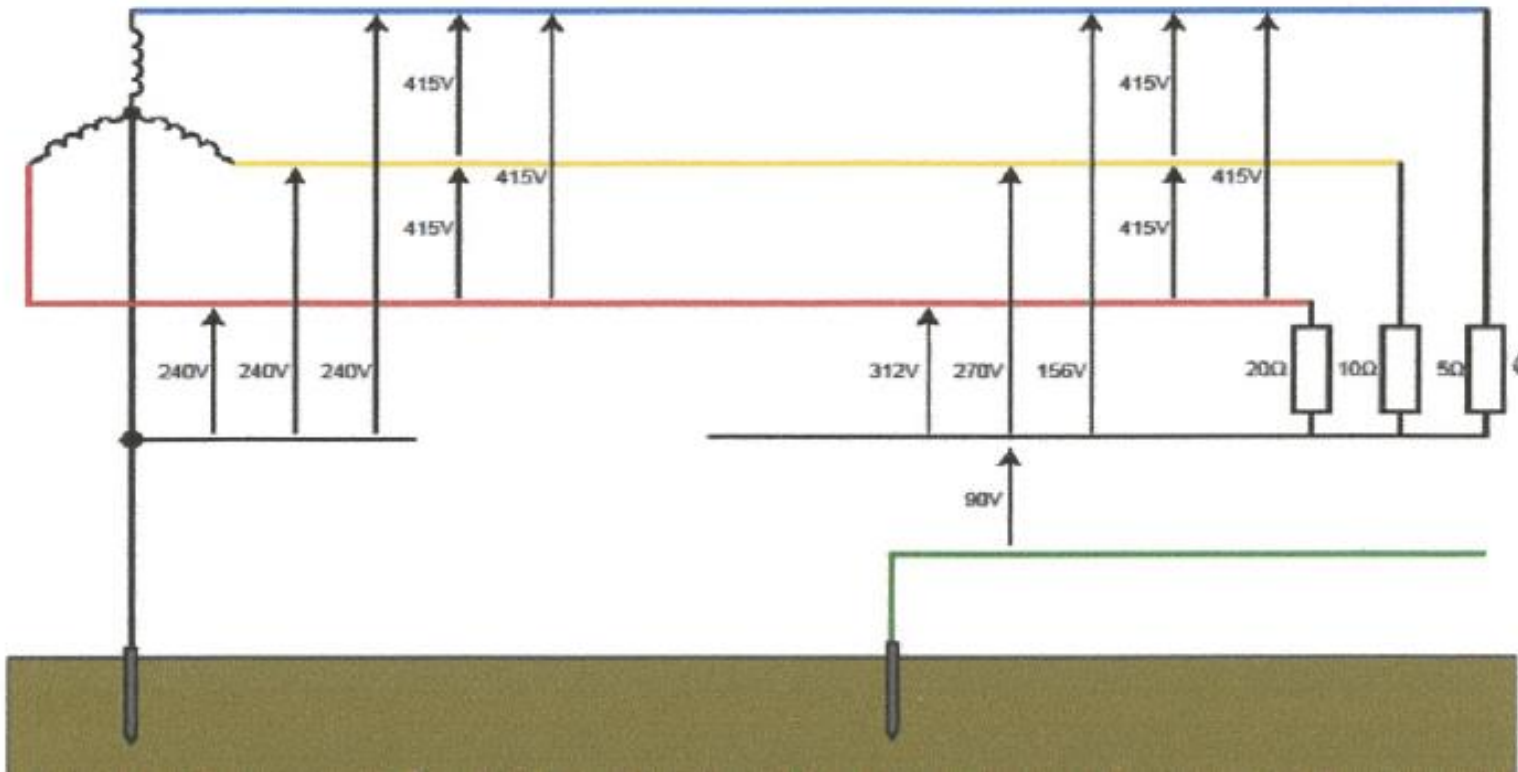

7.3 Connecting Lead Length

- Connecting conductors shall be as short as possible (preferably not exceeding 0.5 m for the total length & in no case exceed 1.0 m)
 - *Connecting conductors are the conductors from the line conductor to the SPD & from the SPD to the switchboard earthing terminal/bar*
- If the total wiring length exceeds 1.0 m, select an SPD with a lower voltage protection level Up (IEC 60364-5-53).

7.3 Connecting Lead Length

- All conductors together with the connections between the SPD and any external circuit breaker, shall be kept as short and as straight as possible and any unnecessary cable loops shall be avoided (IEC 60364-5-53)

7.3 Connecting Lead Length

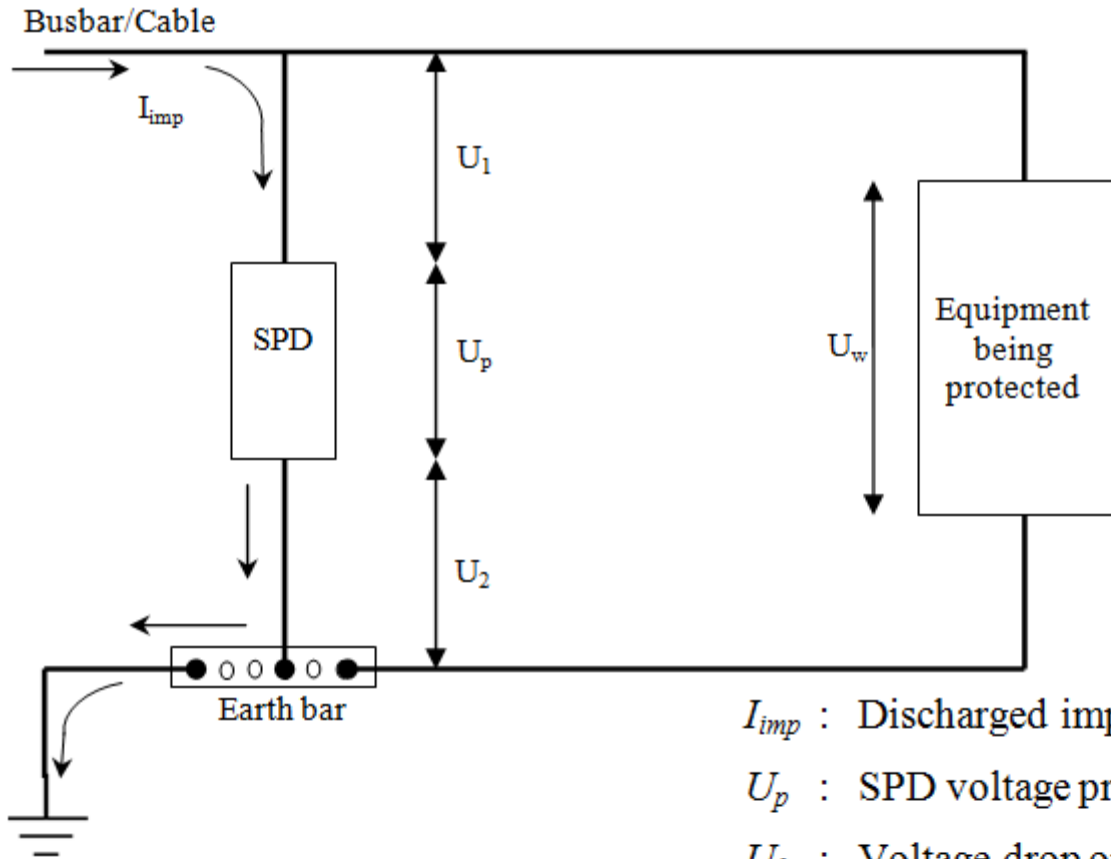

Connecting conductors are the conductors from the line conductor to the SPD & from the SPD to the switchboard earthing bar

I_{imp} : Discharged impulse current

U_p : SPD voltage protection level

U_1 : Voltage drop on the phase side connection of the SPD

U_2 : Voltage drop at the earth side connection of the SPD

U_w : Impulse withstand voltage of the equipment

$$U_1 + U_p + U_2 \leq U_w$$

7.3 Connecting Lead Length

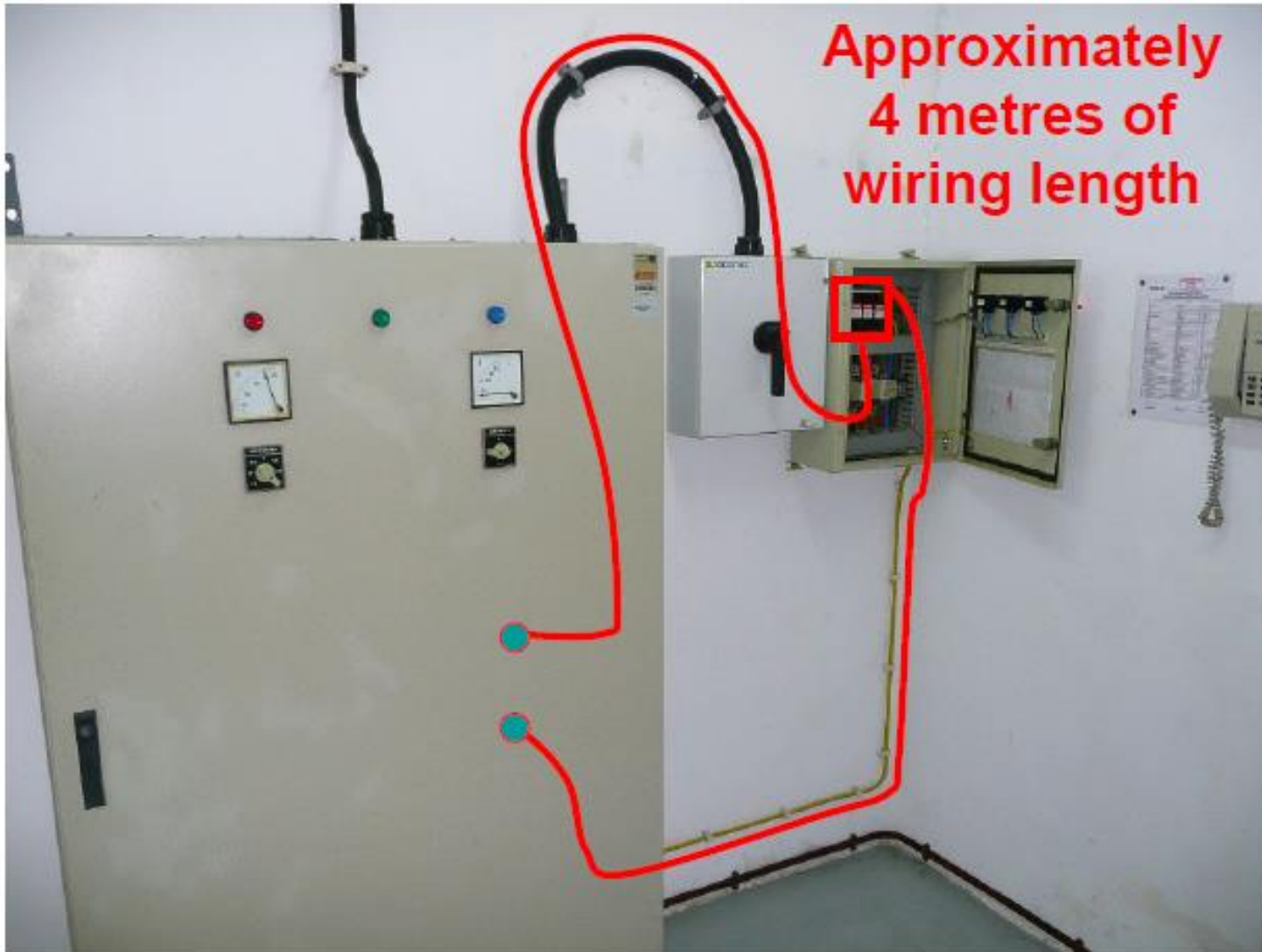

7.3 Connecting Lead Length

Connecting conductors must be as short as possible. This is vital as it minimises the voltage let through to equipment. Twisting shunt-connected leads together, or at least keeping them together also helps to reduce the voltage let through to equipment. An SPD with a protection level suitable for the equipment to be protected should be chosen.

The total length of the connections is $L = L1 + L2 + L3$. It represents an impedance of roughly $1 \mu\text{H/m}$ for high frequency currents. Application of the rule with an $8/20 \mu\text{s}$ wave and a current of 10 kA leads to a voltage of 1296 V peak per metre of cable.

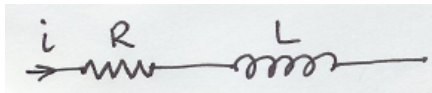

4 mm^2 is $\approx 4.61 \text{ m}\Omega/\text{m}$

$$\Delta U = iR + L \frac{di}{dt}$$

$$\begin{aligned} \Delta U &= (10 \times 10^3)(4.61 \times 10^{-3}) + (1 \times 10^{-6}) \left(\frac{10 \times 10^3}{8 \times 10^{-6}} \right) \\ &= 46.1 + 1250 \\ &= 1296 \text{ V} \end{aligned}$$

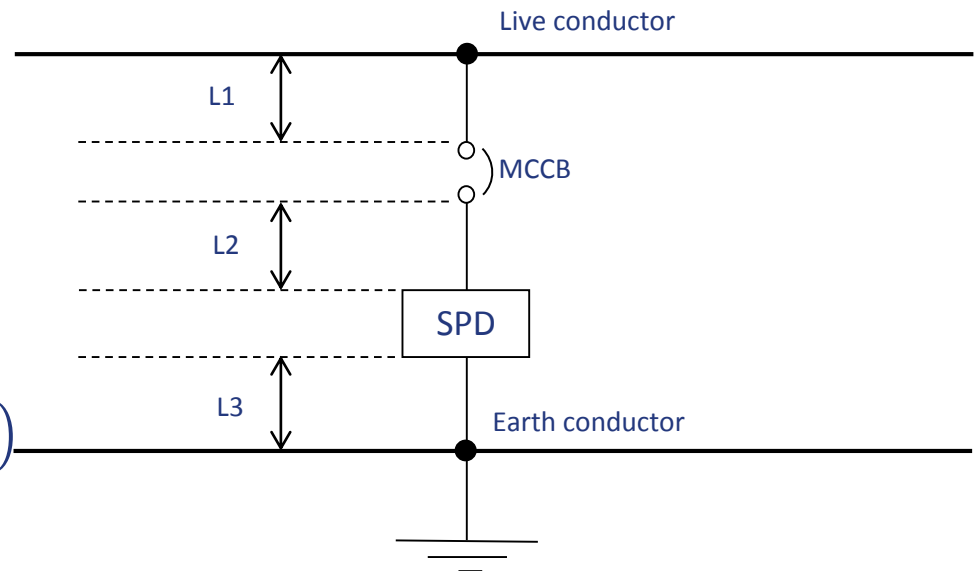

7.3 Connecting Lead Length



7.5 SPD Types & Location

Location Category	1.2/50 μ s (Uoc) Voltage Generator	8/20 μ s (Isc) Current Generator	Voltage Protection Level (Up)	Max. Discharge Current, Imax (8/20 μ s) per mode
Main Switchboard (MSB)	≥ 20 kV	≥ 10 kA	≤ 1800 V	≥ 65 kA
SSB receiving energy from MSB located in the same building	≥ 10 kV	≥ 5 kA	≤ 1500 V	≥ 40 kA
SSB receiving energy from MSB located in other building	≥ 20 kV	≥ 10 kA	≤ 1800 V	≥ 65 kA
DB receiving energy from SSB located in the same building <i>(for cases where the SSB located in the same building with MSB)</i>	≥ 6 kV	≥ 3 kA	≤ 1200 V	≥ 20 kA
DB receiving energy from SSB located in the same building <i>(for cases where the SSB located in other building with MSB)</i>	≥ 10 kV	≥ 5 kA	≤ 1500 V	≥ 40 kA
DB receiving energy from the licensee or MSB/SSB located in other building	≥ 20 kV	≥ 10 kA	≤ 1500 V	≥ 40 kA
Socket Outlet or Terminal Equipment	≥ 2 kV	≥ 1 kA	≤ 500 V	≥ 10 kA

7.5 SPD Types & Location

- SPDs installed at the origin of the electrical installation shall be Type 1 or Type 2 (IEC 60364-5-53)

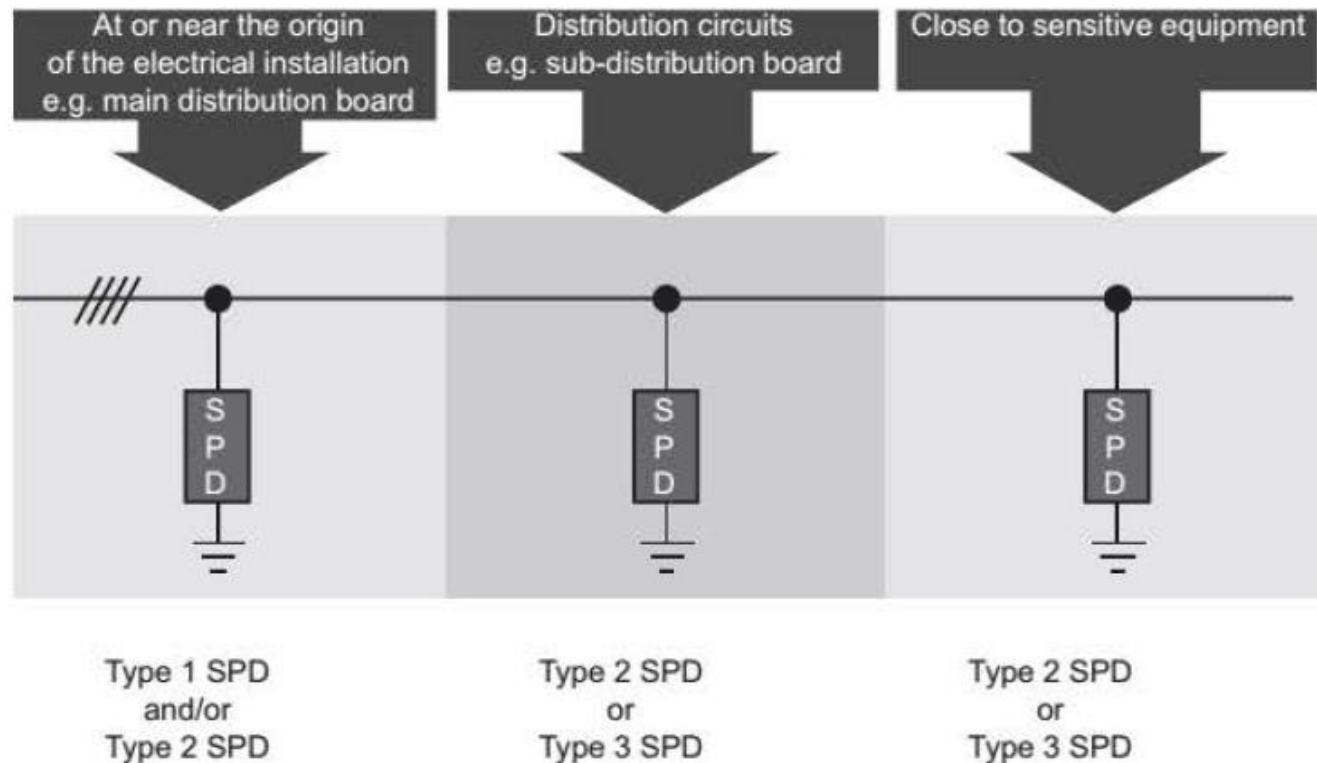

7.5 SPD Types & Location

- Typically, Type 1 SPDs are used at the origin of the installation, Type 2 SPDs are used at distribution boards and Type 3 SPDs are used near terminal equipment

SPD according to IEC 62305	SPD according to IEC 61643-11
SPD tested with I_{imp}	Type 1
SPD tested with I_n	Type 2
SPD tested with a combination wave	Type 3

7.6 Disconnecting Devices

- MCCB (3-pole) or fuse (IEC 61643-11, sub-clause 7.2.5.1)
- For MCCB, the breaking capacity of the MCCB should comply with the rated ultimate short circuit breaking capacity (I_{cu}) for the switchboards or DB (IEC 61643-11, sub-clause 7.2.5.3/8.3.5.3). I_{cs} should be 50% of I_{cu}
- The rated current of MCCB or fuse should be recommended by SPD's manufacturer

7.7 Interaction between SPDs & Other Devices

- SPDs should be connected on the line side of RCDs (such as RCCBs). Failure to do so may encourage nuisance tripping

7.8 Installation of SPDs

- The incoming cable and outgoing cables should be well separated. This prevents surges being induced from the unprotected (polluted/dirty) incoming cable to the protected (clean) outgoing cables.

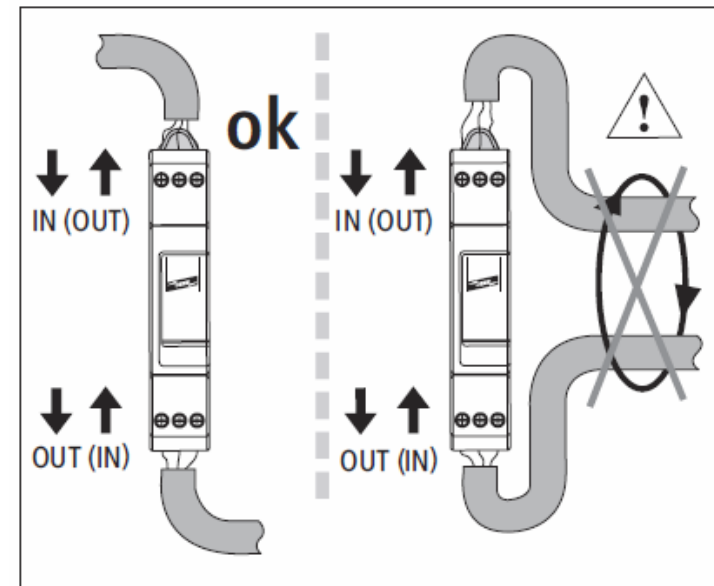

7.8 Installation of SPDs

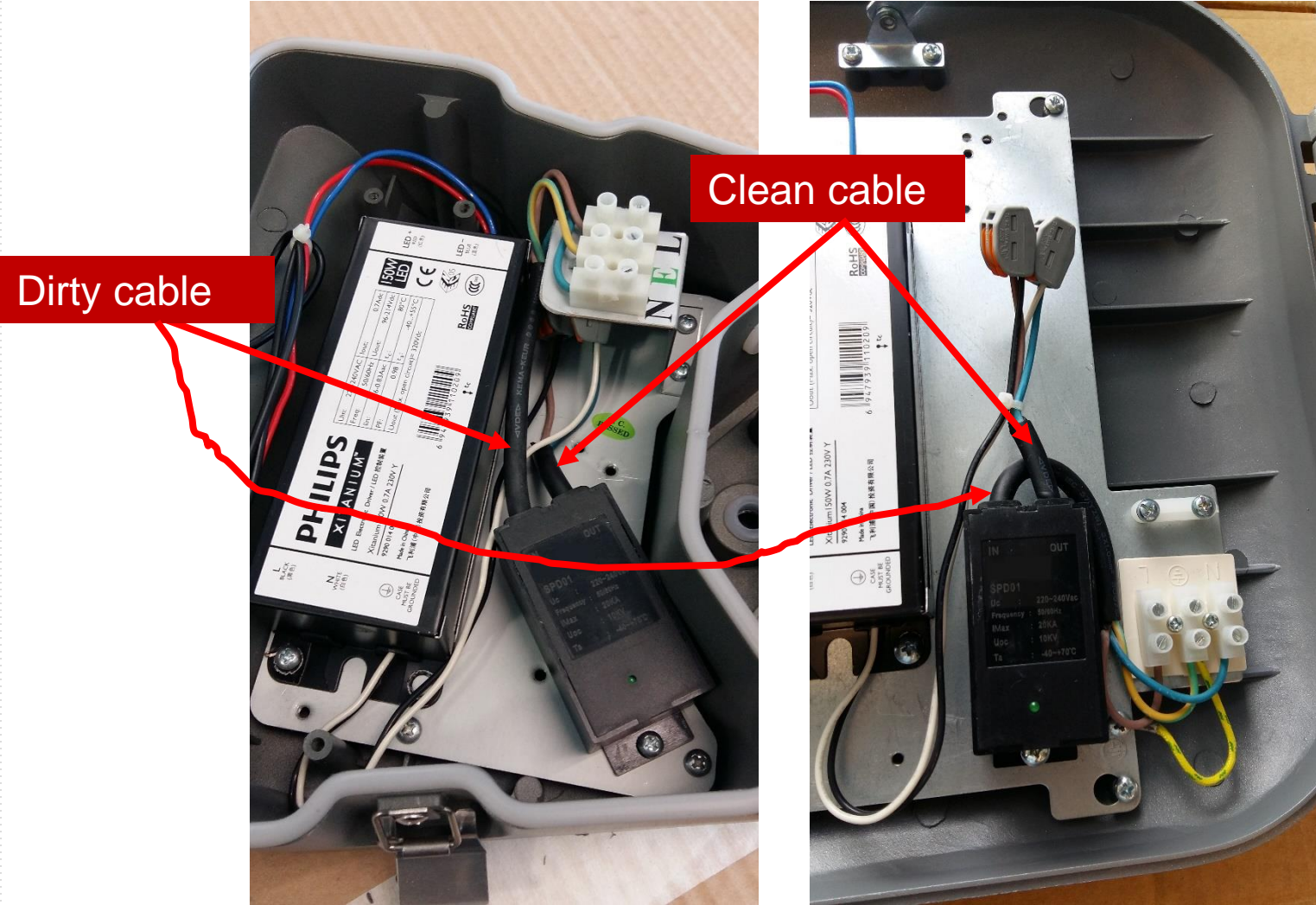

7.9 Single Line Schematic Wiring Diagram

- Switchboard
- DB



7.10 On Site Installation

- SPD and its associated equipment shall be housed in a separate compartment at immediate lower subsection

- Note:*
- a) SPD compartment must be totally compartmentalized with clear transparent cover
 - b) SPDs shall be connected after the incoming circuit breaker



7.10 On Site Installation

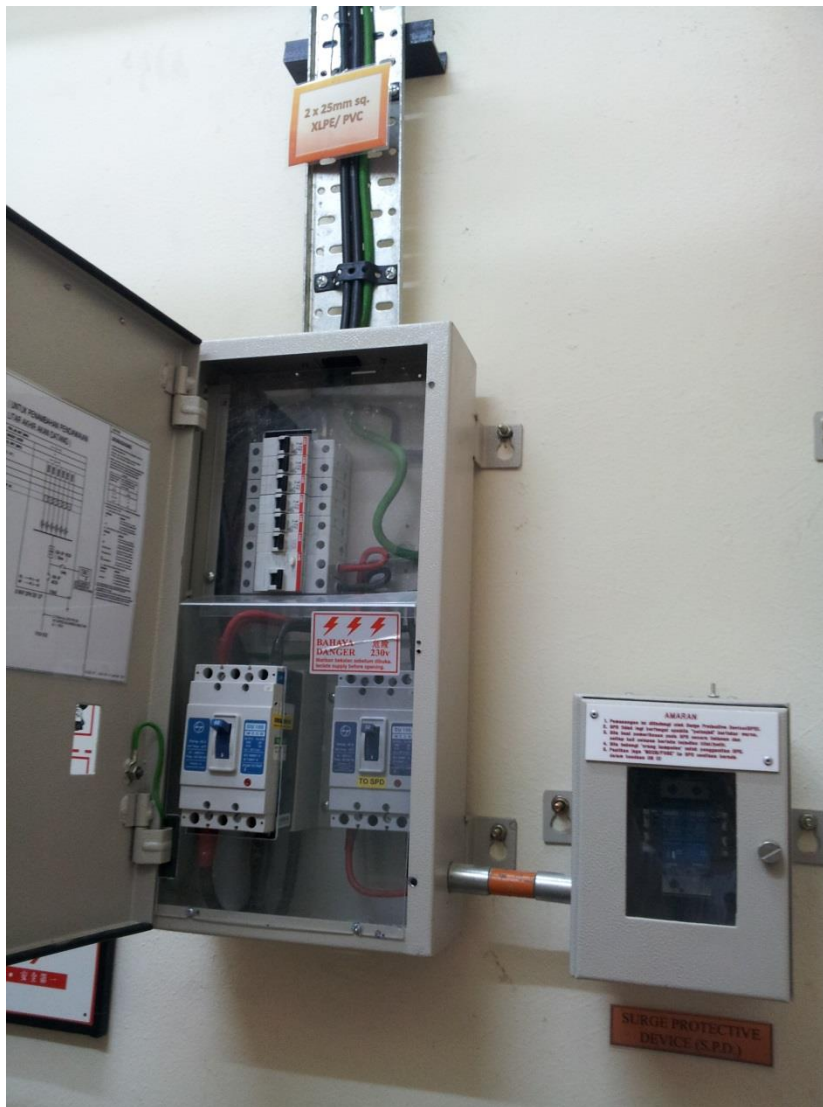

7.10 On Site Installation



7.11 Status Indicator

Many of the SPDs are not inspected once they are installed and the user is not aware of their operating status. Therefore, a durable label with **red lettering on a white background** with words as stated below shall be fastened externally on the front cover of the SPDs compartment.

AMARAN

1. Pemasangan ini dilindungi oleh Surge Protective Device (SPD).
2. SPD tidak lagi berfungsi apabila “petunjuk” bertukar warna.
3. Sila buat pemeriksaan pada SPD secara bulanan dan setiap kali selepas berlaku kejadian kilat/petir.
4. Sila hubungi ‘orang kompeten’ untuk penggantian SPD.
5. Pastikan juga ‘circuit breaker’ ke SPD sentiasa berada dalam keadaan ON (I).

7.12 Inspection

Periodic inspection of SPDs according to MS IEC 62305-3:

- Visual inspection of the status indication of an SPD
- SPDs for telecommunications and signalling networks mostly have no status indication or remote contact

7.12 Inspection

Status indication of an SPD

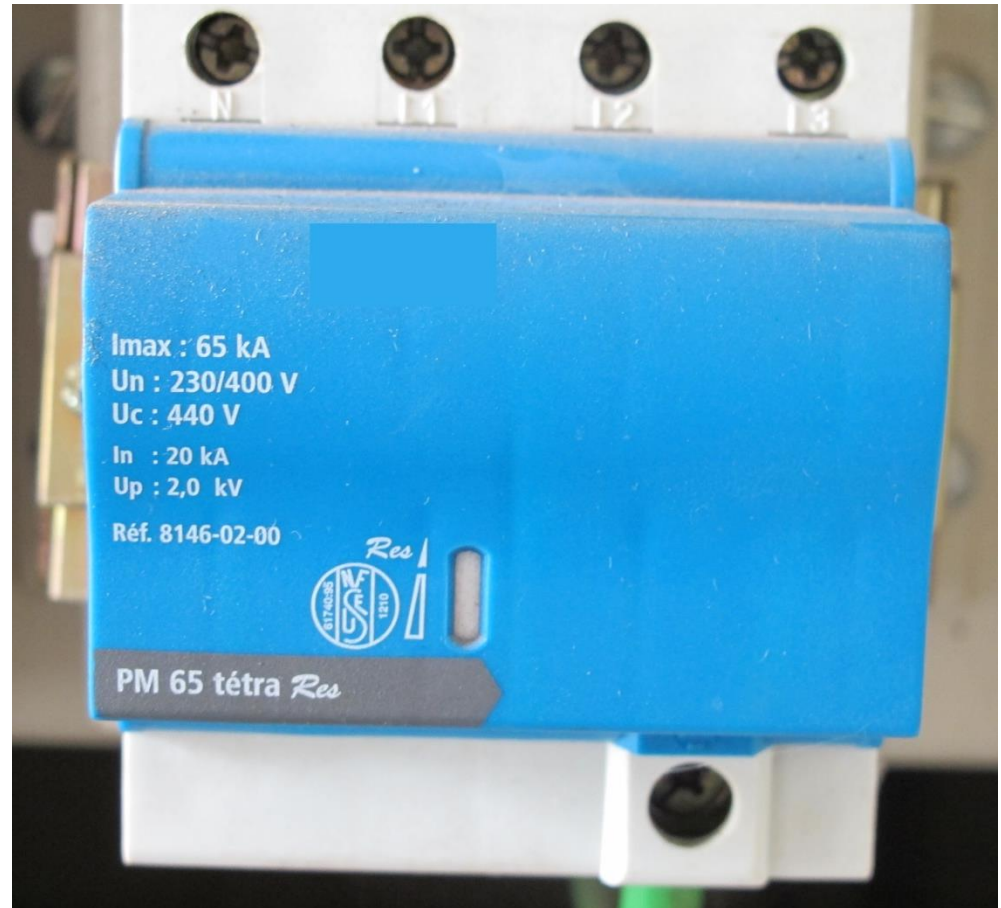

7.12 Inspection

Check	Look for	Reason
SPDs	<ul style="list-style-type: none"> • Installed at MSB, SSBs, DBs and critical equipment • To minimize high frequency impedance, connecting leads should be short, with no bends 	<ul style="list-style-type: none"> • Lightning is high energy and needs multilevel protection • Lightning has high freq components. Shorter connecting leads have less X_L and less impedance at high freq.
Earth Electrode at MSB	<ul style="list-style-type: none"> • Earth electrode connections are not loose or corroded • Earthing conductor should not be coiled or have unnecessary bends 	<ul style="list-style-type: none"> • Ensure low earth resistance to minimize potential to earth with lightning induced surges • Minimize impedance to high freq components of lightning
Earth Electrode Bonding	All earth electrodes should be effectively bonded together ($<0.1 \Omega$)	Prevent difference in earth potential between electrodes in event of lightning
Datacom cabling that runs between building	SPDs on datacom cabling or use of fiber optic cables	Datacom cabling run between buildings can be a path for surge currents

8. Alternative to the installation of SPDs

Double Wound Shielded Isolation Transformer

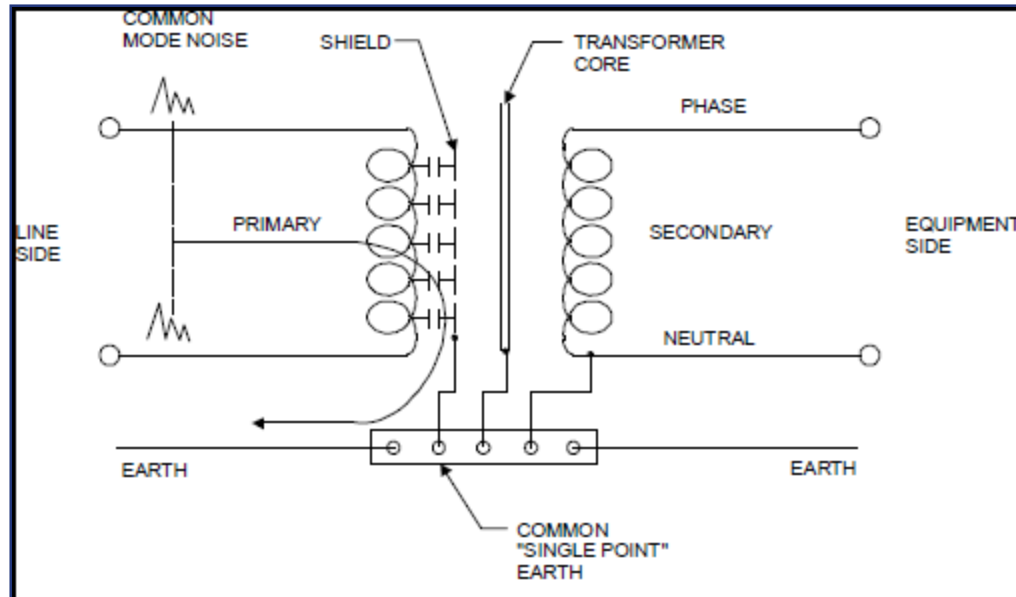

Isolation transformer to be connected as a separately derived system. It should be placed near to the load.

What Type of Learner are You?





Thank You

Hamzahis.jkr@1govuc.gov.my



3 September
2020