

	MATERIAL/TYPE	CONDITION ANALYSIS	RATING (1 - 5)
	R.C. PIPE		2
	NONE		N/A
	NONE		N/A
	NONE		N/A
	R.C. PIPE		2
	BITUMINOUS		2
	NONE		N/A
	CONCRETE HEADWALL		3
	NONE		N/A
	NONE		N/A

CROSS SECTION

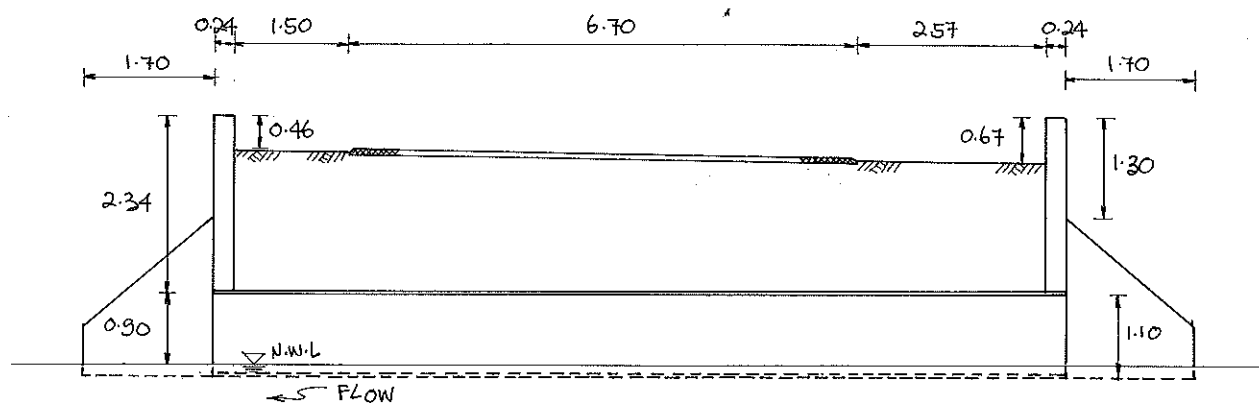

SCALE: 1 : 100

LONG SECTION

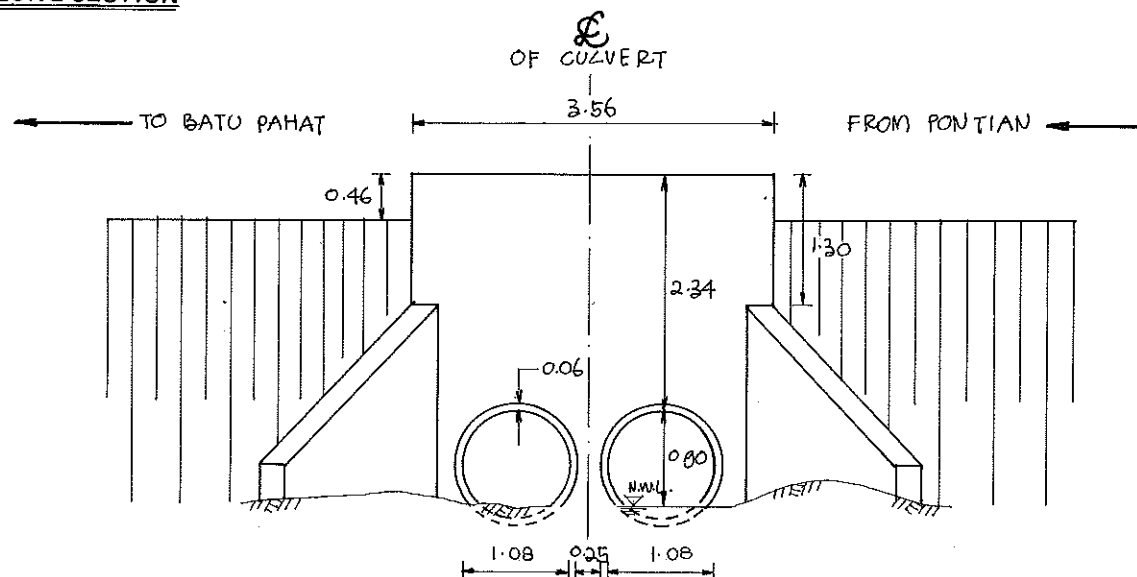

SCALE: 1 : 75

CALCULATION REFERENCES AND MAINTENANCE NOTES:

CONSTRUCTION :