

# KERAJAAN MALAYSIA

## MANUAL ON TRAFFIC CONTROL DEVICES TEMPORARY SIGNS AND WORK ZONES CONTROL



©2017 Jabatan Kerja Raya Malaysia.

Hak Cipta Terpelihara.

Tidak dibenarkan mengeluarkan mana-mana bahagian artikel, ilustrasi dan isi kandungan buku ini dalam apa jua bentuk dan dengan apa jua cara sama ada secara elektronik, mekanikal, salinan, rakaman atau cara lain sebelum mendapat keizinan bertulis daripada penerbit.

Manual on Traffic Control Devices  
Temporary Signs and Work Zones Control

ISBN 978-967-5957-78-9



9 789675 957789

Jabatan Kerja Raya  
Cawangan Jalan



Ketua Pengarah Kerja Raya  
Jabatan Kerja Raya Malaysia  
Jalan Sultan Salahuddin  
50582 Kuala Lumpur



ATJ 2C/85 (Pindaan 2017)

MANUAL ON TRAFFIC CONTROL DEVICES TEMPORARY SIGNS AND WORK ZONES CONTROL

## **FOREWORD**

The purpose of this new manual Arahan Teknik (Jalan) 2C/85 (Pindaan 2016), hereinafter called ATJ 2C/85 (Pindaan 2017) Manual on Traffic Control Devices: Temporary Signs and Work Zones Control is to establish uniformity in the design and application of all traffic signage and control devices in Malaysia for the benefit of road users, road and traffic authorities and manufacturers of traffic signs.

This manual supersedes and forms part of the revised version of JKR/J(Rb) 0001/80, Manual On Traffic Control Devices – Traffic Signs. The manual is now divided into the following parts:-

- 1) ATJ 2A/85 – Standard Traffic Signs.  
Standard traffic signs drawings for Regulatory, Warning and Guide signs are illustrated complete with dimensions. A coloured chart for all the traffic signs indicating the acceptable colours for each sign.
- 2) ATJ 2B/85 – Traffic Sign Application.  
It consists of, with the exception of Temporary signs, design criteria and location requirements for all traffic signs.
- 3) ATJ 2C/85 – Temporary Signs and Work Zones Control.  
It consists of standard temporary sign drawings and their applications in the work zones.
- 4) ATJ 2D/85 – Road Markings and Delineation  
Standard road line paints, road markings and delineators are identified together with guides on their applications.
- 5) ATJ 2E/87 – Guide Signs Design and Application  
It covers among others, general requirements, principles, classification and latest design layout for guide signs.

The specifications in this manual are recommended to be used for all new signage and for all replacements of existing signage which have outlived their usefulness.

This document has also been arranged to comply with the current Road Transport Act and Road Transport Rules, wherever applicable.

This manual will be reviewed and updated from time to time to cater for the changes on policies and current requirements. In this respect any comments and feedback regarding this manual should be forwarded to Bahagian Pembangunan Inovasi & Standard, Pakar Kejuruteraan Jalan & Jambatan, Cawangan Jalan.

Published by:-

Cawangan Jalan  
Ibu Pejabat JKR Malaysia

## ACKNOWLEDGEMENT

This ATJ 2C/85 (Pindaan 2017) was prepared by a working committee comprised of the following members:

### *Committee Members*

Ir. Hj. Wan Abdul Rahman bin Hassan (Chairman)	JKR
Ir. Mohd. Azahar bin Don	JKR
Ir. Abdul Rahman bin Baharuddin	JKR
Ir. Razhiah binti Wahab	JKR
Ir. Mohd. Yusup bin Zahidin	JKR
Ir. Mohd. Shahrom b. Ahmad Saman	JKR
Ir. Atikah binti Zakaria	JKR
Ir. Mohamad Sharip bin Wahijan	JKR
Pn. Siti Nurilam binti Abu Mansor	JKR
En. Tengku Mohamad Shahril bin tengku Razman	JKR
Pn. Munirah binti Hasan	JKR
Ir. Nurrul Hudha Haryati binti Amzah	JKR
Pn. Rosmawati binti Abdul Razak	JKR
En. Amirul Ain bin Amran	DBKL
En. Samsul bin Jaharudin	Supplier
En. Abd. Karim bin Hj. Mohammed	Consultant
En. Zainady bin Zakaria	Contractor
Ir. Mohamed Shafii bin Mustafa	Safety Auditor
En. Adi Marwan bin Munawar	Consultant
Cik Suriati binti Mahmud	Consultant

Special thanks and appreciation to the proof reader: -

Ir. Mohd. Azahar Bin Don Cawangan Jalan

Finally, the publisher would like to express its gratitude to the above committee members for their substantial contribution towards the successful completion of this document.

A special thanks to Dato' Dr. Ir. Meor Aziz bin Osman, Deputy Director General of Works (Infra Sector), Ir. Zulakmal bin Haji Sufian, Senior Director of Road Branch, Dato' Ir. Hj. Che Noor Azeman bin Yusoff, Director of Road and Bridge Design, Ir. Dr. Lim Char Ching, Director of Forensics Engineering and Technical Support Division, *Cawangan Jalan, Jabatan Kerja Raya Malaysia* for their support and contribution towards the successful completion of this manual.

**MANUAL ON TRAFFIC CONTROL DEVICES**  
**TEMPORARY SIGN AND WORK ZONE CONTROL**

<b>CONTENTS</b>		<b>PAGE</b>
<b>PART ONE: WORK ZONE CONTROL</b>		<b>1</b>
1.0	THE NEED FOR TRAFFIC MANAGEMENT AT WORK ZONES	2
1.1	Background	2
1.2	Traffic Safety at Work Zones	2
1.3	Issues of Traffic Management at Work Zones	3
1.4	Possible Solutions to Traffic Management at Work Zones	4
2.0	THE PRINCIPLES OF TRAFFIC MANAGEMENT AT WORK ZONES	
2.1	Purpose of Traffic Management at Work Zones	5
2.2	Construction Activities Requiring Traffic Management	5
2.3	The Principles of Traffic Management at Work Zones	5
3.0	STRATEGIES FOR EFFECTIVE IMPLEMENTATION OF TRAFFIC MANAGEMENT AT WORK ZONES	7
3.1	During the Detailed Engineering Design Phase	8
	3.1.1 Design of the conceptual Traffic Control Plan (TCP)	8
	3.1.2 Costing of TCP in the Bill Of Quantities	8
3.2	During Pre-Construction Phase	9
3.3	During the Construction Phase	9
	3.3.1 Strategies for Execution of the TMP	9
	3.3.2 STEP 1- Set up Monitoring Framework	9
	3.3.3 STEP 2- Set up Working Teams	10
	3.3.4 STEP 3- Design of Localised TCP for Each Work Zones	12
	3.3.5 STEP 4- Use of Standardised Approaches	13
	3.3.6 STEP 5- Preparation of the Traffic Management Safety Report	13
	3.3.7 STEP 6- Audit of Traffic Management During Construction	13
3.4	Responsibilities	13
	3.4.1 Responsibilities of the SO/PD (Superintending Officer/Project Director) / Representative	13
	3.4.2 Responsibilities of the Supervising Engineers	14
	3.4.3 Responsibilities of the Contractor	14
	3.4.4 Responsibilities of the Traffic Management Officer (TMO)	15
	3.4.5 Responsibilities of the Road Safety Auditor	16

<b>CONTENTS</b>	<b>PAGE</b>	
4.0	PLANNING OF TRAFFIC MANAGEMENT AT WORK ZONES	17
4.1	The Planning Process	17
4.1.1	STEP 1: Assemble Data	17
4.1.2	STEP 2: Select the Traffic and Construction Duration Categories	19
4.1.3	STEP 3: Determine Extent of Roadway Occupancy	20
4.1.4	STEP 4: Identify Feasible Work Area Types	20
4.1.5	STEP 5: Impact Analysis	21
4.1.6	STEP 6: Select Preferred Traffic Management Plan	21
4.1.7	STEP 7: Check for Mitigation Requirement	21
4.2	The Traffic Study	22
4.3	Performance Indicators	22
4.4	Emergency Response Team (ERT) Requirement	24
5.0	DESIGNING A TRAFFIC MANAGEMENT AT WORK ZONES	25
5.1	Different Types of Traffic Management Plans(TMP)	26
5.1.1	The Traffic Management Plan Proposal	26
5.1.2	Traffic Control Plans	28
5.1.3	Strategies for Best Design Practice of Traffic Control Plan	28
5.2	Design of Work Zones	29
5.2.1	Advance Warning Area	30
5.2.2	Transition Area	30
5.2.3	Buffer Area	32
5.2.4	Work Area	32
5.2.5	Termination Area	33
6.0	TYPICAL LAYOUTS OF THE TRAFFIC MANAGEMENT PLAN	35
6.1	General	35
6.1.1	The Traffic Category	35
6.1.2	The Construction Duration Category	35
6.2	Sign Arrangements	40
6.2.1	Advance Warning Area	40
6.2.2	Transition Area	41
6.2.3	Buffer And Work Area_	41
6.2.4	Termination Area	41
6.3	Modification of Typical Layouts	48
6.4	Consideration of Parameters of Typical Layouts	48
6.5	Considerations to Modifying the Typical Layouts	49
6.6	Typical Application Layouts	49

<b>CONTENTS</b>		<b>PAGE</b>
7.0	TAKING OFF QUANTITIES	55
7.1	Objective	55
7.2	Practices In Estimating BQ For Traffic Management	55
	7.2.1 Previous Practice	55
	7.2.2 Current Practice	55
7.3	Taking Off Quantities	56
	7.3.1 Example of Case Study 1: Short/Long Term Works Where Traffic Is Detour (Rural Low Speed)	56
	7.3.2 Example of Case Study 2: Temporary Diversion at Intersection of Single Carriageway (Urban Low Speed)	59
	7.3.3 Example of Case Study 3: Short/Long Term Works Where Traffic Is Detour on Bridge (Rural High Speed)	62
	7.3.4 Conclusion	64
8.0	PLACEMENT AND REMOVAL OF TRAFFIC CONTROL DEVICES	65
8.1	Preparation for Placement Process	65
	8.1.1 Preparation for Placement Process	65
	8.1.2 Coordination with Affected Groups	65
	8.1.3 Inventory and Storage	65
	8.1.4 Training and Instruction	66
8.2	Placement	66
	8.2.1 Placement Sequence	66
	8.2.2 Placement Procedure	67
	8.2.3 Placing Channelizing Devices	67
	8.2.4 Lateral Position	67
	8.2.5 Cone Placement	68
	8.2.6 Expressway Lane Closures	68
	8.2.7 Exterior Lane Closures	68
	8.2.8 Interior or Center Lane Closures	68
8.3	Modification and Removal	69
8.4	Special Equipment and Techniques	69
9.0	MAINTENANCE OF TRAFFIC CONTROL ZONES	70
9.1	Inspection and Maintenance Program	70
	9.1.1 Elements of an Inspection Program	70
9.2	Inspection Procedures	71
	9.2.1 Responsibility	71
	9.2.2 Frequency	71
	9.2.3 Documentation	72
	9.2.4 Record Keeping	72

<b>CONTENTS</b>	<b>PAGE</b>
9.3 Training and Equipment Needs	73
9.3.1 Training	73
9.3.2 Personnel, Equipment and Materials	74
10.0 REPORTS	
10.1 The Traffic Management Plan Proposal	75
10.2 Traffic Management Safety Reports (TMSR)	76
<b>PART TWO: TEMPORARY TRAFFIC CONTROL DEVICES</b>	<b>77</b>
1.0 GENERAL	78
2.0 CATEGORY OF TRAFFIC CONTROL DEVICES	78
2.1 Temporary Signage	78
2.2 Temporary Road Marking	79
2.3 Temporary Management Equipment	103
APPENDIX A: BORANG PEMERIKSAAN RUTIN ZON KERJA	A-1
APPENDIX B: COLOUR CODE FOR TRAFFIC SIGN	B-1

## ABBREVIATIONS

1) Abbreviations used in this Manual shall have following meaning:

ADT	Average Daily Traffic
BQ	Bill of Quantity
ERP	Emergency Response Plan
ERT	Emergency Response Team
JKR	Jabatan Kerja Raya
PE	Professional Engineer
PPE	Personal Protection Equipment
RE	Resident Engineer
RSA	Road Safety Audit
SE	Supervising Engineer
SO/PD	Superintending Officer/Project Director
TCD	Traffic Control Device
TCP	Traffic Control Plan
TMO	Traffic Management Officer
TMP	Traffic Management Plan
TMSR	Traffic Management Safety Report
TMT	Traffic Management Team
TMWZ	Traffic Management at Work Zone
TS	Traffic Supervisor

2) Abbreviations of units of measurement used in this Manual shall have following meaning:

c/c	centre to centre
hr	hour
kg	kilogram
m	metre
km	kilometre
kph	kilometre per hour

3) The words or phrases used in this Manual shall have following meaning:

- a) 'Traffic Management Plan' refers to a compiled document consisting of method statement of Traffic Management, work programme, Traffic Control Plan, organization chart etc....
- b) 'Traffic Control Plan' refers to the detailed drawing that shows the placement of Traffic Control Devices according to the construction sequence.
- c) 'Personal Protection Equipment' refers to a set of safety equipment that consists of (but not limited to) safety helmet, reflective uniform / safety vest, and safety boots.

For JKR Internal Use Only

**PART ONE**  
**WORK ZONE CONTROL**

For JKR Internal Use Only

## **1.0 THE NEED FOR TRAFFIC MANAGEMENT AT WORK ZONES**

### **1.1 Background**

Whenever work is done on or near the roadway, drivers are faced with changing and unexpected traffic conditions. These changes may be hazardous for motorists, workers, and pedestrians unless protective measures are taken.

Motorists may not be able to differentiate between the various types of construction sites and the unexpected dangers in the work zone areas. Hence, proper traffic control measures and safety considerations are required for all types of work both on major long term projects or those of short duration.

This Manual has been designed and written to explain the application of standards to the various work situations. The Manual should be used by everyone who is involved with planning, designing, installing, maintaining, and inspecting traffic control at work sites. The illustrations can be used for a quick guide and reference for various examples of Traffic Control Plan.

Handling traffic in work zones is challenging because the work activities present an abnormal and often disruptive environment to the motorists. Motorists accustomed to a clear, unobstructed roadway are required to recognize and avoid closed lanes, workers in or near the roadway, and a variety of fixed object hazards. Pedestrians expecting a clear, direct walking path can be faced with closed sidewalks and open trenches closer to the moving traffic. The construction activities may also present a distracting view to many motorists that can divert their attention from the driving task.

Work zones are often dynamic, and the layout of the traffic control is changed as the works progress. As such, the motorists and pedestrians are constantly being confronted with new challenges and disruptive elements in their travel path. There are many instances where this has led to serious accidents, some including fatalities.

### **1.2 Traffic Safety at Work Zones**

The Work Zone is the distance between the first advance warning sign and the point beyond the termination area where traffic is no longer affected. A typical Work Zone should have the following areas:

- (a) Advance Warning Area
- (b) Transition Area
- (c) Buffer Area
- (d) Work Area
- (e) Termination Area

Traffic safety is a major issue at work zones. When the travelling path of motorist is occupied for work activity, conflict arises between the requirements of the construction workers and the desire of smooth un-interrupted traffic flow by motorists. Work sites create potential hazards because they:

- (a) Confront the motorists with unexpected and often confusing situations;
- (b) Create obstructions which the motorists have to avoid;
- (c) Disrupt the motorist's attention from the driving task; and
- (d) Expose the construction workers to more and often speeding traffic.

The potential for severe and fatal crashes are greatest within the work zone. The proportion of multiple-vehicle crashes is also the highest within the work zones.

In work zone, the following crashes may occur:

- (a) Mostly within the Work Area.
- (b) Rear end collision in Advance Warning Areas.
- (c) Side Swipe crashes, most common in Transition Areas
- (d) Fixed-object-off-road and angle crashes in Work Areas.

More fixed-object crashes during night time.

Crash types that have higher frequency of occurrence during construction are:

- (a) Fixed Object
- (b) Rear End
- (c) Head On

### **1.3 Issues of Traffic Management at Work Zones**

General problems associated with local work zones are attributed to:

- (a) Poor management of traffic flow.
- (b) Inadequate Traffic Control Devices.
- (c) Inappropriate signage.
- (d) Lack of maintenance of signage and control devices.
- (e) Speeding traffic.
- (f) Lack of day time and night time safety auditing of the work zones.
- (g) High incidence of traffic crashes
- (h) Late / Non-removal of Traffic Control Devices upon completion.
- (i) Inadequate provisions for vulnerable road users.

This Manual provides a more updated standard on traffic management at work zones taking into account the volume and composition of traffic on the roads. The existing publications and standard drawings issued by the Road Authorities are sufficient to ensure good design and best practice in a work zone. However, proper implementation of traffic management at work zones should be the prime focus for improving mobility and safety of road users.

#### 1.4 Possible Solutions to Traffic Management At Work Zones

The probable solutions to these problems of implementing improvements to traffic safety at work zones include the following remedial actions:

- (a) The Road Authorities and the Supervising Engineers must review the Traffic Management Plans as to ensure this Manual and current best practices are implemented and optimum materials used.
- (b) The existing templates for the Traffic Management Plans may require more detailed consideration for the introduction of additional information/guide signs; use of the VMS and promoting appropriate use of barrier systems; and provide for the needs of pedestrians, cyclists and motorcyclists.
- (c) The new additions to the Standard Specifications must be strictly implemented or possible litigation may arise in the event of an accident.
- (d) Lastly, there must be constant surveillance both day and night checks to ensure that the good design and best practice in traffic management at work zones are adhered to. Requirements of good traffic management practices must be met to ensure that the Contractors comply with the specifications and legal requirements.

## **2.0 THE PRINCIPLES OF TRAFFIC MANAGEMENT AT WORK ZONES**

### **2.1 Purpose of Traffic Management at Work Zones**

The purpose of Traffic Management at Work Zones is to ensure the mobility and safety of workers and to provide safe passage for motorists, pedestrians, and workers through the road works site. Traffic Management at Work Zones must incorporate the following key elements:

- (a) warn motorists and pedestrians of roadworks hazard ahead.
- (b) provide safe travel paths through the works area for the travelling public including pedestrians, at all times, day or night, and in all weather conditions.
- (c) provide a safe work area for workers and road users.

### **2.2 Activities Requiring Traffic Management**

Work zone traffic management is needed for a wide variety of activities on roads and highways as follows:

- (a) Construction
  - Roadway reconstruction or resurfacing
  - Roadway widening projects
  - Storm drains and sewers
  - Replacement of public utilities
  - Bridge deck replacement
- (b) Minor maintenance works
  - shoulder repairs
  - guardrail repair
  - shoulder mowing
  - pavement striping
  - ditch cleaning
- (c) Major maintenance works
  - pavement joint repair
  - culvert repairs
  - bridge repairs
- (d) Utility operations
- (e) Emergency situations such as vehicle breakdowns or road accidents

### **2.3 The Principles of Traffic Management at Work Zones**

- (a) Make traffic safety an integral and high priority element of every project.
  - Use geometries and traffic control devices that are comparable to those of normal road situations.
  - Prepare a traffic management plan that is easily understood by all persons responsible for work zone traffic control.

- (b) Avoid inhibiting traffic flow as much as possible.
- Avoid reduced speed zoning except where required.
  - Avoid frequent and abrupt changes in geometrics.
  - Provide for the safe operation of work vehicles.
  - Minimize work time to reduce exposure.
  - Schedule work during off-peak periods.
- (c) Guide motorists in a clear and concise manner.
- Use adequate warning, delineation, and channelization to give guidance for all light and weather conditions. expected during the work activity.
  - Remove inappropriate pavement markings.
  - Use flagging only when other methods of traffic control are inadequate.
- (d) Perform routine inspection of traffic control elements.
- Assign individuals trained in safe traffic control the responsibility for safety at worksites.
  - Make modifications to traffic controls or working conditions when necessary.
  - Monitor work sites under varying conditions of traffic volume, light, and weather.
  - Perform engineering analysis of all accidents in work zones.
  - Analyse work zone accident records to guide officials in improving work zone operations.
  - Remove traffic control devices immediately when they are no longer needed.
- (e) Give constant attention to roadside safety.
- Provide clear roadside recovery area as wide as practical.
  - Use lightweight channelization devices, which will yield on impact.
  - Provide appropriate barriers to protect workers and errant road users.
  - Store construction equipment, materials and debris in a manner, which will minimize the opportunity for run-off-road vehicle impacts.
  - Use latest technology / materials to provide advance information and enhanced visibility to all road users.

### 3.0 STRATEGIES FOR EFFECTIVE IMPLEMENTATION OF TRAFFIC MANAGEMENT AT WORK ZONES

#### DESIGN PHASE

- Road Design Engineers to prepare overall TCP design.
- Road Design Engineers to prepare Bill of Quantities.
- Road Safety Auditor to audit in RSA Stage 3.

#### PRE-CONSTRUCTION PHASE

- Contractor to prepare TMP proposal for the project
- Contractor appoints TMO.
- Road Safety Auditor to audit the TMP in RSA Stage 4 Part 1.

#### CONSTRUCTION PHASE

- SO/PD sets up TMWZ Monitoring Framework.
- Contractor to establish TMT, ERT (if required), and prepare TCP and TMSR.
- Road Safety Auditor to audit Traffic Management during construction.

The Traffic Management at Work Zones requires thorough planning and design as to ensure a high and satisfactory level of safety is provided for all road users. A well thought-out Traffic Management Plan (TMP) will reduce the number and severity of accidents, slow down traffic and minimize public complaints.

One of the major aims of this Manual is to propose strategies for the effective implementation of traffic management at work zones. The strategies involve the following:

- (a) The preparation of conceptual "Traffic Control Plan (TCP)" for the entire project by Road Design Engineers during the Detailed Engineering Design Stage.
- (b) The preparation of a Bill of Quantities for the TMWZ, which will be part of the Tender Document.
- (c) The setting up of a framework to manage and monitor the TMWZ activities.
- (d) The preparation of Traffic Management Plan (TMP) for the Project by the Contractor during the Pre-Construction Phase
- (e) The appointment of a Traffic Management Officer (TMO).
- (f) The setting up of the Traffic Management Team and the Emergency Response Team where it is warranted.
- (g) The TMO to prepare Traffic Control Plans (TCP) for the local work zones and are submitted through the Traffic Management Safety Reports (TMSR), at every three (3) months interval or as instructed by the S.O.
- (h) The daily inspections, corrective actions and maintenance of the Work Zones by TMO.
- (i) The Road Safety Auditor will audit the TMP at the RSA Stage 4 Part 1. In addition, all TCPs for local work zones will be audited as they are submitted through the TMSR.

The above strategies outline the procedures for planning, designing and implementing the Traffic Management Plans. It also outlines the roles and responsibilities of the persons involved in the implementation of the Traffic Management at Work Zones.

The procedures and steps to be taken are as follows:

### **3.1 During the Detailed Engineering Design Phase**

#### **3.1.1 Design of the conceptual Traffic Control Plan (TCP)**

Design of the conceptual Traffic Control Plan (TCP) by the Road Design Engineers.

- (a) The Road Design Engineers must design a conceptual TCP appropriate for the construction sequences of the facilities which they have designed for.
- (b) At this level, the TCP must cover the overall project site.
- (c) The designed TCP must be audited by the Road Safety Auditor during the RSA Stage 3 Audit.

#### **3.1.2 Costing of TCP in the Bill Of Quantities**

- (a) The Road Authorities or the person/parties carrying out works on the road (e.g. Developers) should allocate funds for the execution of traffic management at work zones.
- (b) For the purpose of costing, Consultants and Contractors are to refer to the requirements specified in the Chapter 7 of this Manual.

### 3.2 During Pre-Construction Phase

- (a) Within one (1) month of the site possession, the Contractor must come up with their Traffic Management Plan of the project for the approval of the SO/PD. This TMP shall be submitted for auditing by the Road Safety Auditor (RSA). This audit is carried out in the RSA 4 Pt 1 (Verification and TMP Audit) Stage.
- (b) The Contractor to appoint certified Traffic Management Officer (TMO) within one (1) month after site possession.
- (c) The TMP must be made known to the local authorities, local communities, and road users well in advance of any construction works.
- (d) The TMP must also be made known to the JKR District and JKR State, especially if it involves road/lane closure or major road diversion.
- (e) Before any planning on the Traffic Management Plan (TMP) commences, the Contractor must visit the site for field checks and to collect inventory of the existing facilities including existing structure, services and public facilities such as street lighting, traffic light, bus and taxi stops and road furniture that may require removal or relocation during the construction stage.
- (f) In addition, the Contractor should assess the existing road capacity, determine the existing travel and distribution patterns and identify potential problems that might arise due to temporary road diversions. The Contractor should also carry out discussion with the local authorities on the effect of the construction works on the existing traffic patterns and the occurrences of any local festivities / activities / upgrading programs.

### 3.3 During the Construction Phase

#### 3.3.1 Strategies for Execution of the TMP

For the execution of the TMP, a six-step strategy is proposed. These are:

- (a) STEP 1: Set up a Monitoring Framework
- (b) STEP 2: Set up Working Teams
- (c) STEP 3: Design Localised TCPs for each Work Zone
- (d) STEP 4: Use of Standardised Approaches
- (e) STEP 5: Prepare the Traffic Management Safety Reports (TMSR)
- (f) STEP 6: Audit of Traffic Management during construction

#### 3.3.2 STEP 1- Set up Monitoring Framework

The first step in ensuring a successful implementation of the Traffic Management Plan during the construction phase is to set up a framework where the Contractor, the Supervising Engineers and the Client (Road Authorities) work together in implementing the Traffic Management Plans. The SO/PD shall lead this team to ensure smooth running of the strategies. The roles of the parties are as illustrated in the **FIGURE 3.1**.

The Monitoring Framework shall be set up within one (1) month after the date of site possession.

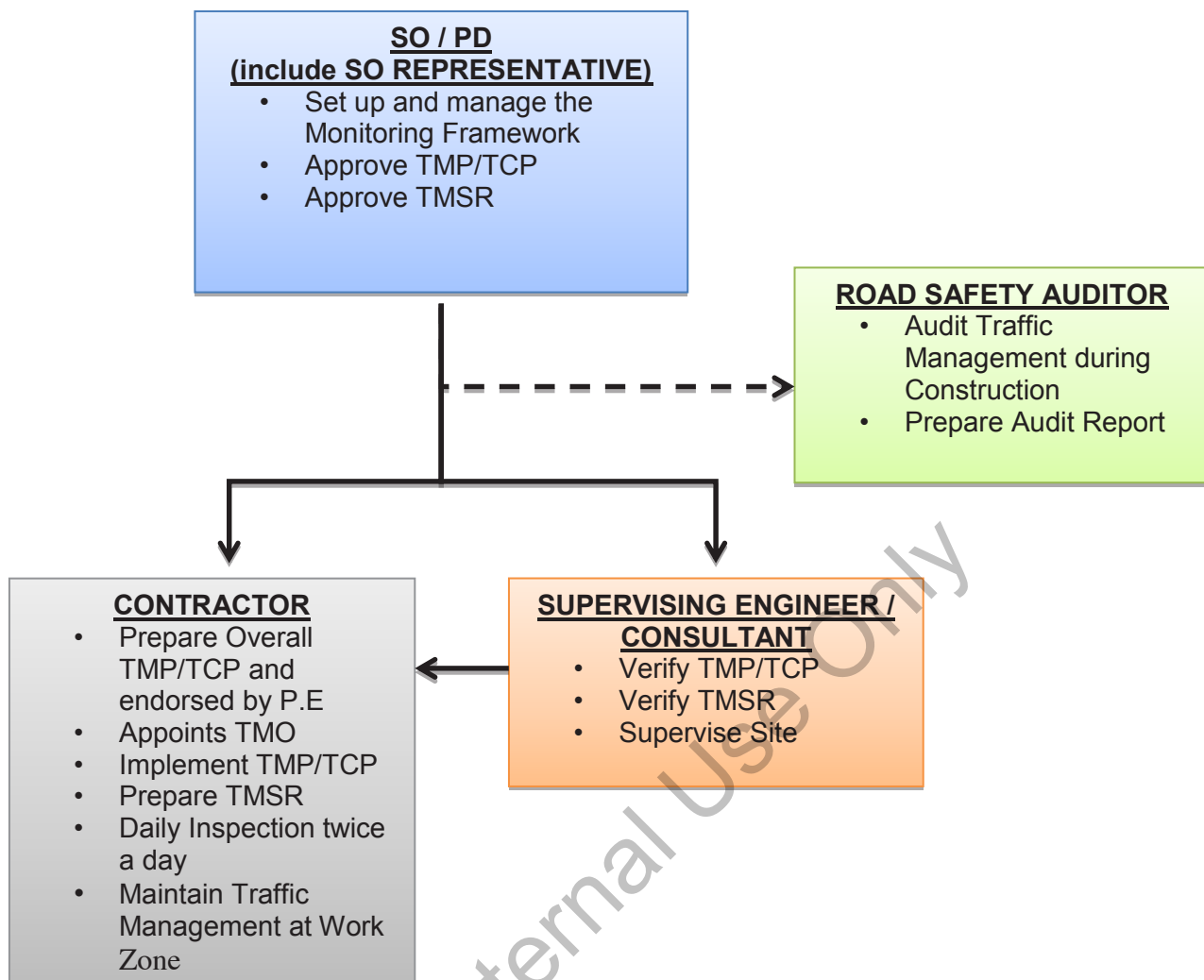

**FIGURE 3.1: FRAMEWORK TO MONITOR TRAFFIC MANAGEMENT AT WORK ZONE**

### 3.3.3 STEP 2- Set up Working Teams

To ensure a smooth construction sequence without compromising public road safety for pedestrians and other road users, the Contractor needs to set up two distinct teams, each with their unique roles and responsibilities. They are the Traffic Management Team (TMT) and the Emergency Response Team (ERT) as illustrated in **FIGURE 3.2**

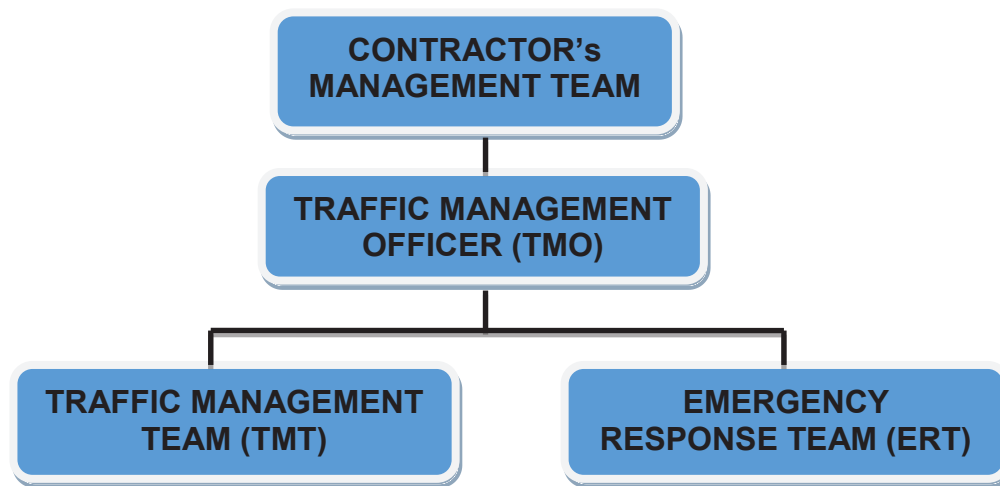

*Note:*

1. TMT is required for all road works
2. ERT is only required if its absence is anticipated to result in undue delay/congestion during construction (such as high traffic volume, protocol road, major diversion) and it has to be identified during the detail design stage.

**FIGURE 3.2: TRAFFIC MANAGEMENT TEAM AND EMERGENCY RESPONSE TEAM**

**(a) Traffic Management Team**

The role of the Traffic Management Team (TMT) is to ensure that the Traffic Control Plan is implemented in accordance with the approved plan. Their duties include proper installation, maintenance and cleaning of Traffic Control Devices (TCD). In addition, they will ensure that all lane closures and traffic diversions are implemented in compliance with all traffic management procedures as per the authority requirement.

The team is also responsible to ensure the safety and smooth traffic flow through the period of road closure. The person-in-charge of the TMT must regularly inspect the situation of traffic flow and update the SO/PD on the prevailing traffic conditions. The team must be able to establish an effective line of communication for emergencies and changes in circumstances.

There are occasions that may necessitate the reroute of traffic to opposite traffic lanes in contra flow for activities such as the launching of bridge beams, the construction of a bridge pier and at interchanges in the middle of existing roadways.

Traffic management personnel should be present at site during the duration of construction including weekends, public holidays, and under any weather conditions.

Traffic management personnel should be equipped with complete PPE.

**(b) Emergency Response Team (ERT) – when warranted**

The role of the ERT is to provide a 24-hour patrol for the full domain of the construction zone. They will liaise with TMT, contractor, tow-truck operators, traffic police and relevant parties in the event of a road accident, stalled vehicles, landslides, ground failures and flash floods that may occur at any time within the construction zone.

In addition, the ERT will report to the TMO on any incidence of poor housekeeping by Contractors. They shall be on the lookout for inappropriate or poor condition signboards and other TCD. Particular attention must be given to public safety in areas of open excavations.

TMO should prepare an Emergency Response Plan (ERP) that will include all likely events that may cause disruptions to the smooth flow of traffic at the approach to and at the construction site. The Emergency Response Team is responsible to implement the ERP. An orderly chain of command needs to be established by the ERT to inform all parties of any emergencies and enable the SO/PPD and/or his representative to make well informed decisions, including informing the Police and the media, to overcome/mitigate the effects of the emergencies and minimize inconvenience to road users. Organisation chart of ERT and a copy of ERP are to be submitted to the SO/PPD and District Engineer for their information and record.

**3.3.4 STEP 3- Design of Localised TCP for Each Work Zones**

The Traffic Control Plans (TCP) are required for all Work Zones. It is the responsibility of the TMO to prepare the TCPs. Before distributing to the parties involved, the TCP must be vetted by the Supervision Engineers who will then verify the designed TCP.

Each work zone will have a specific TCP with a specific reference number to it. Whenever there is a change of traffic control on the site, this must be reflected in the TCP being displayed. The TCP must also have specific Placement Date and Removal Date. A copy of the endorsed TCP shall be forwarded to the S.O./PPD for approval and acceptance.

The Localised TCP have to be designed at least three months before the placement dates.

### **3.3.5 STEP 4- Use of Standardised Approaches**

This Manual provides a framework for the STANDARDISATION OF DESIGN of the Traffic Management Plans (see **Chapter 6**).

The Work Zones are standardised based on the location and the speed of traffic on the road. These will then translate into the various sizes of the Traffic Control Zones. The sign faces are also standardised to feature different shapes for use on the expressways and other roads.

The Manual also proposes standardisation on the use of Traffic Control Devices. This will be based on the duration of the Construction Period of each Work Zone.

### **3.3.6 STEP 5- Preparation of the Traffic Management Safety Report**

The Traffic Management Safety Reports (TMSR) is essential in the execution of the project. These reports are to be submitted at 3-month or 6-month intervals to the SO/PD, Supervision Engineers and the Road Safety Auditor. These reports are to be prepared by the Traffic Management Officer. A more detailed requirement of the report is laid out in Chapter 10.

### **3.3.7 STEP 6- Audit of Traffic Management During Construction**

The TCPs shall be included in the TMSR. The Road Safety Auditor shall carry out the audit of TCPs within two (2) weeks of receiving the TMSR. The audit will cover TCPs in the TMSR as well as on site during implementation of the TCPs.

## **3.4 Responsibilities**

### **3.4.1 Responsibilities of the SO/PD (Superintending Officer/Project Director)/ Representative**

The SO/PD/ Representative must follow these procedures;

- (a) Be mindful of the Government's responsibilities and legal implications of providing, as far as practical, safe and convenient travelling conditions for road users and safe working conditions for personnel and plant under their control.
- (b) Ensure that the traffic safety personnel maintain and remove signs and devices, carry out their works diligently in accordance to design Manuals and procedures.
- (c) Be familiar with, and act in accordance with the provisions of this Manual and all the appropriate legislation.

The duties of the SO/PD/Representative include the following:-

- (a) Chair the Stage 4 Audit meetings to discuss the Road Safety Auditor findings and make decisions based on the Auditor recommendations and response by the Contractor.
- (b) Evaluate the financial, contractual and legal issues arising from compliance/non-compliance to Auditor recommendations based on advice from the SO/PD representative and Road Safety Auditor.
- (c) Set up and manage the framework to monitor the TMP activities.
- (d) Provide scope of Audit works to Road Safety Auditor via the Contractor
- (e) Call for commencement meeting to discuss scope of Audit works and specific conditions and location of the construction site
- (f) Call for Stage 4 meetings to discuss Road Safety Auditor findings
- (g) Prepare minutes of Stage 4 meetings of Road Safety Auditor findings
- (h) Supervise the corrective/improvement measures as directed by the SO/PD.
- (i) Issue work approvals for the next stage of construction.
- (j) Liaison with the enforcement agencies such as PDRM on measures to reduce traffic congestion.
- (k) Inform major road users including truckers, public transport, Keretapi Tanah Melayu (KTM), Malaysia Airline System(MAS) Kargo, etc of any major disruptions to major Federal Roads due to construction works.

#### **3.4.2 Responsibilities of the Supervising Engineer**

The Supervising Engineers shall be responsible for the overall implementation of the Traffic Control Plans (TCP) during construction. The Supervising Engineers shall vet through the TCP prepared by the Contractor.

Apart from the above, the Supervising Engineers are to carry out the following duties:

- (a) Verification of the TCP
- (b) Monitoring the placements and removal of the Traffic Control Devices
- (c) Monitoring the operations of the Traffic Control Devices
- (d) Monitor the occurrences of road accidents within the work zones
- (e) Visiting the site to supervise and inspect the Work Zones during the Construction Phase.

#### **3.4.3 Responsibilities of the Contractor**

The Contractor carrying out construction or maintenance operations on roads or bridges will take due care and diligence to minimize the risk of injury to road users or damages to their properties as a result of such operations. Actions should be taken to warn the public of prevailing conditions and to guard, delineate, and, where necessary, to illuminate works which may pose a hazard to traffic. The Contractor shall take all necessary measures to minimize delays and detours which will inconvenience motorists.

There is a legal requirement on the part of the Contractor to provide a safe working environment for its employees and the travelling public through the work site.

The duties of the Contractor include:

- (a) To appoint a Road Safety Auditor prior to commencing the construction works
- (b) Provide scope of Audit works
- (c) Prepare the Traffic Management Plan (TMP) for the project endorsed by Professional Engineer and submit to SO/PD, Local Authority, PDRM and Road Safety Auditor
- (d) Provide construction program chart to Road Safety Auditor to enable Road Safety Auditor prepare schedule of Stage 4 Audit works
- (e) Prepare response to Road Safety Auditor findings
- (f) Carry out corrective/improvement works as decided upon by the SO/PD
- (g) Inform/advise Road Safety Auditor of the next stage of Audit
- (h) Disseminate information on TMP to public via newspaper, radio, TV, traffic signs, etc (Preferably 2 weeks in advance)

#### **3.4.4 Responsibilities of the Traffic Management Officer (TMO)**

The Traffic Management Officer is the Contractor's representative responsible for all matters related to the traffic management, safety of the travelling public and construction workers within the limits of the construction works / Contract. He supervises both the Traffic Management Team and Emergency Response Team.

The TMO must ensure the following:

- (a) The Contractor's responsibilities in providing safe and convenient travelling conditions for road users and safe working environment for personnel and plants under their control.
- (b) The personnel under their control are employees of the Contractor and should at all times be courteous to the travelling public. Personnel should not allow themselves to be provoked by members of the public and, by exercising restraint, this will strengthen their position both then and at any subsequent enquiry or legal proceedings if ever it arises.
- (c) The traffic controllers assigned to direct traffic or personnel employed to place, maintain and remove signs and devices, are well-trained and fully aware of their duties and responsibilities.
- (d) To act in accordance with the provisions and directives of, this guideline and all the relevant acts.

The Traffic Management Officer is to provide evidence to the S.O. that he has the necessary skills and qualification as stipulated in the Contract.

The duties of the TMO to include and not limited to:

- (a) Designing the TCPs for Localized Traffic Management Plan during construction.
- (b) Monitoring the placements and removals of the Traffic Control Devices.
- (c) Monitoring the operations of the Traffic Control Devices.
- (d) Maintain the effectiveness of the Traffic Control Plans.
- (e) Analyzing the occurrences of road accidents within the work zones.
- (f) Preparing and displaying up-to-date TMP for inspection and audit.
- (g) Preparing the tri-monthly Traffic Management Safety Report (TMSR).

- (h) Prepare Emergency Response Plan (ERP) that shall include all contingencies that can affect the smooth flow of traffic at the approach to and within the construction site (e.g. floods, landslides, stalled vehicles, major sporting events, etc.).
- (i) Oversee the performance and effectiveness of the Emergency Response Team (ERT). This includes 24-hour patrol, liaison with PDRM, and local authorities.
- (j) Give special attention to abnormal traffic operations such as contra flow, bridge diversion, etc.
- (k) To ensure all permits given by the Local Authority(s) is valid.
- (l) Developing Standard Operating Procedures (S.O.P.).
- (m) Prepare and maintaining daily records.

#### **3.4.5 Responsibilities of the Road Safety Auditor**

The role of the Road Safety Auditor is to audit the TMP and the TCPs at the approach to and within the construction site. This includes the observation of the effectiveness of the TCPs and the traffic control devices employed during the day and night. The duties of the Road Safety Auditor include:

- (a) Visiting the site (Preferably together with the Contractor and/or the Consultant)
- (b) Auditing the TCPs at the beginning of the construction to ensure workability and suitability throughout the duration of the construction period.
- (c) The TCPs will be audited as they are submitted through the TMSR.
- (d) Auditing the Work Zones during the Construction Phase. This is normally carried out every three months (Subject to request by SO/PD).
- (e) Preparing the Road Safety Audit reports and sending them directly to all the relevant parties (JKR, Contractor and Consultant).
- (f) Presenting the findings of the Audit Report.

## 4.0 PLANNING OF TRAFFIC MANAGEMENT AT WORK ZONES

The development of work zone traffic management begins with the planning process. This Section details the importance of the planning process and gives an overview of the steps in the process with emphasis is on the relationship between planning and design.

### 4.1 The Planning Process

The overall purpose of the planning process is to select the most appropriate traffic management strategy. The strategy of “Traffic Management at Work Zones” is the basic scheme of moving traffic through or around a construction, or maintenance activity. The type of work to be carried out is the most significant element of the strategy to be considered, which includes length of work zone, duration of work, number of lanes, width of lanes, speed control method and right-of-way control method.

The planning process involves seven steps which are shown in **FIGURE 4.1**.

#### 4.1.1 STEP 1: Assemble Data

The basic data required is a complete description of the work to be performed which covers a wide range of activities such as:

- (a) Construction of new roadside drainage which may have no direct disruption of traffic flow.
- (b) Adding a new lane, reconstructing a highway ramp, or resurfacing a pavement can have extensive impact on traffic.
- (c) Replacing a bridge or culvert which may involve roadway closure and detours with very extensive disruption to traffic.

**TABLE 4.1** summarizes the basic data requirements. The basic information required are described in item A of the table which will be sufficient for most projects. The item B describes the requirement for detour routes or where additional information is required to appraise various options available.

It is important that the designer of the Traffic Management Plans and his/her team to visit the site for field check and gather information on the existing facilities including existing structures, services and public facilities such as street lighting, traffic light, bus and taxi stops and roadside furniture that may require removal during the construction stages.

Data collection, assessment of existing road capacity with traffic movement including the number of lanes, existing islands, medians, kerbs, geometry, existing travel and distribution patterns. Identify potential problems that may arise due to temporary road widening or diversions to be used by contractor.

Desktop studies of existing traffic data will also assist in the planning processes.

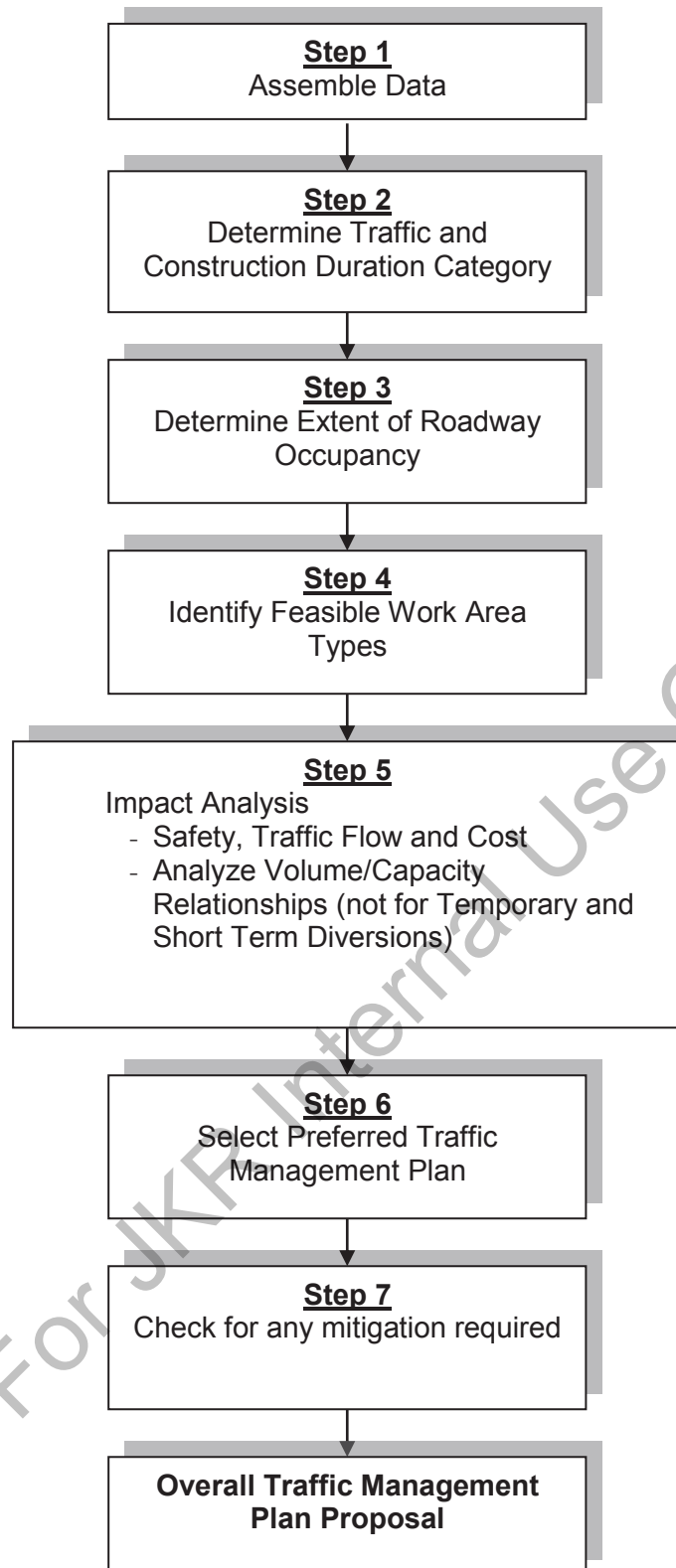

**FIGURE 4.1: THE PLANNING PROCESS**

**TABLE 4.1: SUGGESTED DATA BASE**

<p><b>A. <u>Basic Information</u></b></p> <ul style="list-style-type: none"><li>• Description of Construction Project<ul style="list-style-type: none"><li>- Type of work</li><li>- Roadway encroachment <i>should include the space required by the work activities and equipment, the safety buffer required for adequate work site protection and the physical space occupied by the barricades or other traffic control devices.</i></li><li>- Limits of work</li><li>- Tentative work sequence and work programme</li><li>- Estimated cost</li><li>- Construction category</li></ul></li><li>• Traffic Data<ul style="list-style-type: none"><li>- 24 hour volume counts</li><li>- Roadway geometrics</li><li>- Speed data</li><li>- Description of potential detour routes</li></ul></li></ul>
<p><b>B. <u>Additional Information</u></b></p> <ul style="list-style-type: none"><li>• Roadway Data<ul style="list-style-type: none"><li>- Right of way limitations</li><li>- Horizontal and vertical profiles</li><li>- Type and location of traffic control devices</li><li>- Adjacent lane use</li></ul></li><li>• Traffic Data<ul style="list-style-type: none"><li>- Daily and seasonal volume variations</li><li>- Intersection and Interchange turning movement counts</li><li>- Volume of trucks</li><li>- Signal timing data</li><li>- Accident history</li></ul></li></ul>

(Source: 7<sup>th</sup> MRC 2007– Draft on Traffic Management at Work Zones – An Interim Guidelines)

**4.1.2 STEP 2: Select the Traffic and Construction Duration Categories**

For the purpose of standardization, ease of strategy identification and design, the Work Zones are categorised according to the speed profile and duration of construction as shown in **TABLE 4.2** and **TABLE 4.3** respectively.

**TABLE 4.2: TRAFFIC CATEGORIES**

TRAFFIC CATEGORIES		
ROAD CLASSIFICATION	SPEED PROFILE	SPEED
URBAN	Low Speed	< 60 km/hr
	High Speed	> 60 km/hr
RURAL	Low Speed	< 70 km/hr
	High Speed	> 70 km/hr
EXPRESSWAY	Low Speed	< 90 km/hr
	High Speed	> 90 km/hr

(Source: 7<sup>th</sup> MRC 2007– Draft on Traffic Management at Work Zones – An Interim Guidelines)

**TABLE 4.3: CONSTRUCTION DURATION CATEGORIES**

CLASSIFICATION	DURATION
Temporary Lane Closure	< 1 Day
Short Term Diversion	> 1 Day < 1 Month
Long Term Diversion	> 1 Month

(Source: 7<sup>th</sup> MRC 2007– Draft on Traffic Management at Work Zones – An Interim Guidelines)

#### 4.1.3 STEP 3: Determine Extent of Roadway Occupancy

The type of construction will determine the degree to which the roadway will be occupied and closed to normal traffic, the extent of which will be determined by the following factors:

- (a) The total project length from the start point until the end point.
- (b) The length of the occupied roadway at any one time and during the 24-hour period.
- (c) The portion of the roadway that will be closed to normal traffic.
- (d) The expected number of working days to complete the project.
- (e) The cross section of the road, including the ROW.

Each of the above factors is a function of the work zone strategy and has some flexibility such that traffic disruption can be minimised. As a guide, the number and width of lanes provided through the work zones should, where possible, be the same as the existing roadway.

#### 4.1.4 STEP 4: Identify Feasible Work Area Types

This serves to identify possible work area types such as:

- (a) Lane Narrowing
- (b) Lane Closure
- (c) Shared Right of Way / Contra Flow
- (d) Detour
- (e) Temporary Bypass
- (f) Intermittent Closure
- (g) Use of Shoulder or Median

Based on the extent of roadway occupancy, the cross-sectional characteristics (lane width, shoulder width, right of way, etc.) and considering the constraints imposed by regulations and policies, feasible work area types can now be chosen. Typically, only a small number of work area types will emerge as being feasible for a particular project, and in many cases only one may be possible. Identification of these types in this early stage of the planning process can significantly reduce the analysis effort in subsequent steps.

#### **4.1.5 STEP 5: Impact Analysis**

The purpose of this step is to conduct impact assessment related to safety, traffic flow and cost to evaluate in detail the extent of each impact due to the construction activities. For the Temporary Lane Closure and Short Term Diversions, there is no need to carry out the volume/capacity analysis.

For the Long Term Diversion the general level of roadway congestion should also be identified. The purpose of this step is to analyse in detail and investigate the volume/capacity relationships to allow a complete consideration of each possible strategy.

This step will also determine the roadway capacities of the various work zone strategies and to compare them to the anticipated traffic volumes. When volume exceeds capacity, an estimate of queue length will also be calculated. Depending on the length and duration of the queue, the strategy may have to be abandoned unless additional measures can be taken to increase capacity or reduce demand. Such measures may include restricting work to certain times, making signalization improvements, removing parking, and diverting traffic to other facilities.

#### **4.1.6 STEP 6: Select Preferred Traffic Management Plan**

When all critical impacts are analysed, the most effective strategy will often has less impact on all the measures.

#### **4.1.7 STEP 7: Check for Mitigation Requirement**

Finally, mitigation measures will be necessary for the preferred TMP to minimise impact caused by the construction works. This complete analysis should be carefully documented and used as input to the overall work zone traffic control process.

## 4.2 The Traffic Study

Traffic Management Plan (TMP) requires thorough planning and design so as to ensure that a good and satisfactory level of safety and mobility are provided for all road users during construction.

In order to ensure the effectiveness of TMP during construction, a Traffic Study may need to be carried out to ascertain the Level of Service (LOS). Therefore, it is necessary to know when a Traffic Study is required. This is because all TMP's will advertently worsen the LOS due to the sudden change in traffic flow and waiting/queueing time.

For determination of the LOS and consideration of whether Traffic Study may need to be carried out or otherwise, any of the following traffic conditions under TMP can be used as criteria for its warrant.

- (a) Traffic diversion to routes or junctions outside works limit within an extended period of time
- (b) Change of existing traffic light phasing
- (c) Change of direction in traffic flow during construction period (Example: two way flow becoming one way or vice versa)
- (d) Several options or alternative routes which requires LOS to be determined

The above criteria to be applied, will also be considered together with the duration of TMP to be implemented (recommended > 1 month) and size of project, all these to be ascertained and decided by the S.O./P.D.

## 4.3 Performance Indicators

Whenever traffic study is carried out for a Traffic Management Plan, the results shown in the report should include Delay, Queue Length, Travel time, Degree of Saturation and Level of Service (LOS), whenever applicable.

For the analysis of an intersection, the performance indicators involved are Delay, Queue Length, Degree of Saturation and Level of Service (LOS). The following tables show the relationship between Delay, Degree of Saturation and Level of Service (LOS).

**TABLE 4.4: LEVEL OF SERVICE BASED ON DELAY TIME (FOR INTERSECTIONS)**

Level of Service	Control delay per vehicle in seconds (d)	
	Signals	Sign Control
<b>A</b>	≤ 10.0	0 – 10.0
<b>B</b>	> 10.0 - 20.0	> 10.0 - 15.0
<b>C</b>	> 20.0 - 35.0	> 15.0 - 25.0
<b>D</b>	> 35.0 - 55.0	> 25.0 - 35.0
<b>E</b>	> 55.0 - 80.0	> 35.0 - 50.0
<b>F</b>	> 80	> 50

(Source: Malaysian Highway Capacity Manual 2006, Highway Planning Unit, Ministry of Works)

**Note:**

*v* = volume of traffic

*c* = capacity of road

Queue Length is an important performance indicator at intersections to determine the sufficiency of lengths of lane. This is extremely important when it involves a storage lane. From the Queue Length parameters, it is also able to determine if the back-of-queue will cause a probability of blockage to the upstream traffic and the probability of short lane overflow.

For the analysis of a link, or more commonly known as mainline traffic, the performance indicators involved are Density, Speed, Travel time, Delay and Level of Service (LOS). Travel time is the time spent travelling from a point to another and is usually related to the speed that a vehicle can travel at. Travel time can be used to calculate the delay and subsequently measure the performance and Level of Service of a road.

Delay is defined as “The additional travel time experienced by a driver, passenger, or pedestrian, which is the difference in the actual travel time as compared to the ideal travel time.” Since the definition of “delay” depends on a hypothetical “ideal travel time,” what constitutes a delay then is not always directly measurable in the field and a judgement of an acceptable “delay time” during construction and implementation of its TMP can only be made at site, based on factors and conditions affecting the traffic flow.

For a Two-Lane Highways, the Level of Service is often related to Percentage (%) Time-Spent-Following and Average Travel Speed (km/h) as shown in the figure below.

**TABLE 4.5 : LEVEL OF SERVICE (LOS) BASED ON PERCENTAGE (%) TIME-SPENT-FOLLOWING AND AVERAGE TRAVEL SPEED (KM/H), FOR TWO-LANE HIGHWAY**

LOS	PERCENTAGE TIME-SPENT-FOLLOWING (%)	AVERAGE TRAVEL SPEED (KM/H)
A	≤ 35	≥ 70
B	≤ 50	≥ 60
C	≤ 65	≥ 50
D	≤ 80	≥ 40
E	> 80	≥ 30

(Source: Malaysian Highway Capacity Manual 2011, Highway Planning Unit, Ministry of Works)

\* LOS F applies whenever the flow rate exceeds the segment capacity

As for a MultiLane Highways, the Level of Service (LOS) can be related to Density and Average Speed (km/h) which subsequently affects the travel time and delay.

The S.O./P.D. can ascertain for himself, based on either **TABLE 4.4** (Intersections), **TABLE 4.5** (Two -Lane Highway) or **TABLE 4.6** (Multilane Highway), which is the prevalent LOS under controlled traffic environment while the TMP is in progress, and take necessary measures to address and improve the traffic flow condition.

A desirable LOS to be maintained would be status quo or its current LOS before TMP. However, in view of traffic having to slow down in most road construction work zone, if not all, this desirable LOS may not be attainable. Under such circumstances, then the S.O./P.D. shall take all necessary measures to mitigate or arrest the apparent drop in LOS in order to maintain an acceptable LOS, at worst that of LOS ‘D’ or LOS ‘E’. This may involve the effective control of traffic by experienced flagmen, the rephrasing of permanent/temporary traffic lights, opening up of more lanes or even rerouting traffic, if necessary.

**TABLE 4.6 : LEVEL OF SERVICE (LOS) BASED ON DENSITY AND AVERAGE SPEED (KM/H), FOR MULTILANE HIGHWAY**

Base Free-Flow Speed (km/h)	Criteria	LOS				
		A	B	C	D	E
110	Maximum density (pc/km/ln)	7	11	16	22	26
	Average speed (km/h)	102.9	99.1	95.0	90.5	87.0
	Maximum volume to capacity ratio (v/c)	0.31	0.47	0.66	0.87	1.00
	Maximum service flow rate (pc/km/ln)	720	1090	1520	1990	2300
100	Maximum density (pc/km/ln)	7	11	16	22	26
	Average speed (km/h)	95.7	93.6	91.3	87.3	84.6
	Maximum volume to capacity ratio (v/c)	0.30	0.47	0.66	0.87	1.00
	Maximum service flow rate (pc/km/ln)	670	1030	1460	1920	2200
90	Maximum density (pc/km/ln)	7	11	16	22	28
	Average speed (km/h)	85.7	82.7	79.4	76.8	74.0
	Maximum volume to capacity ratio (v/c)	0.29	0.43	0.60	0.80	1.00
	Maximum service flow rate (pc/km/ln)	600	910	1270	1690	2100
80	Maximum density (pc/km/ln)	7	11	16	22	28
	Average speed (km/h)	78.6	76.4	75.0	73.2	71.0
	Maximum volume to capacity ratio (v/c)	0.28	0.42	0.60	0.81	1.00
	Maximum service flow rate (pc/km/ln)	550	840	1200	1610	2000
70	Maximum density (pc/km/ln)	7	11	16	22	30
	Average speed (km/h)	68.6	67.3	66.3	64.1	63.3
	Maximum volume to capacity ratio (v/c)	0.25	0.39	0.56	0.74	1.00
	Maximum service flow rate (pc/km/ln)	480	740	1060	1410	1900
60	Maximum density (pc/km/ln)	7	11	16	22	31
	Average speed (km/h)	60.0	60.0	59.4	59.5	59.0
	Maximum volume to capacity ratio (v/c)	0.23	0.37	0.53	0.73	1.00
	Maximum service flow rate (pc/km/ln)	420	660	950	1310	1800

(Sources: Malaysian Highway Capacity Manual 2011, Highway Planning Unit, Ministry of Works.)

\* Density is the primary determinant of LOS. LOS F is characterized by highly unstable and variable traffic flow. Prediction of accurate flow rate, density, and speed at LOS F is difficult.

#### 4.4 Emergency Response Team (ERT) Requirement

Requirement for ERT is on project basis and its inclusion in the contract, if necessary, shall take into consideration the following criteria:

- (a) Protocol road.
- (b) Access to strategic and security location.
- (c) Major arterial and collector.
- (d) Urban area with minimum of 4 lanes and more than 10 km length
- (e) Rural area major collector with project length of more than 20 km.

**5.0 DESIGNING A TRAFFIC MANAGEMENT AT WORK ZONES (DURING CONSTRUCTION)**

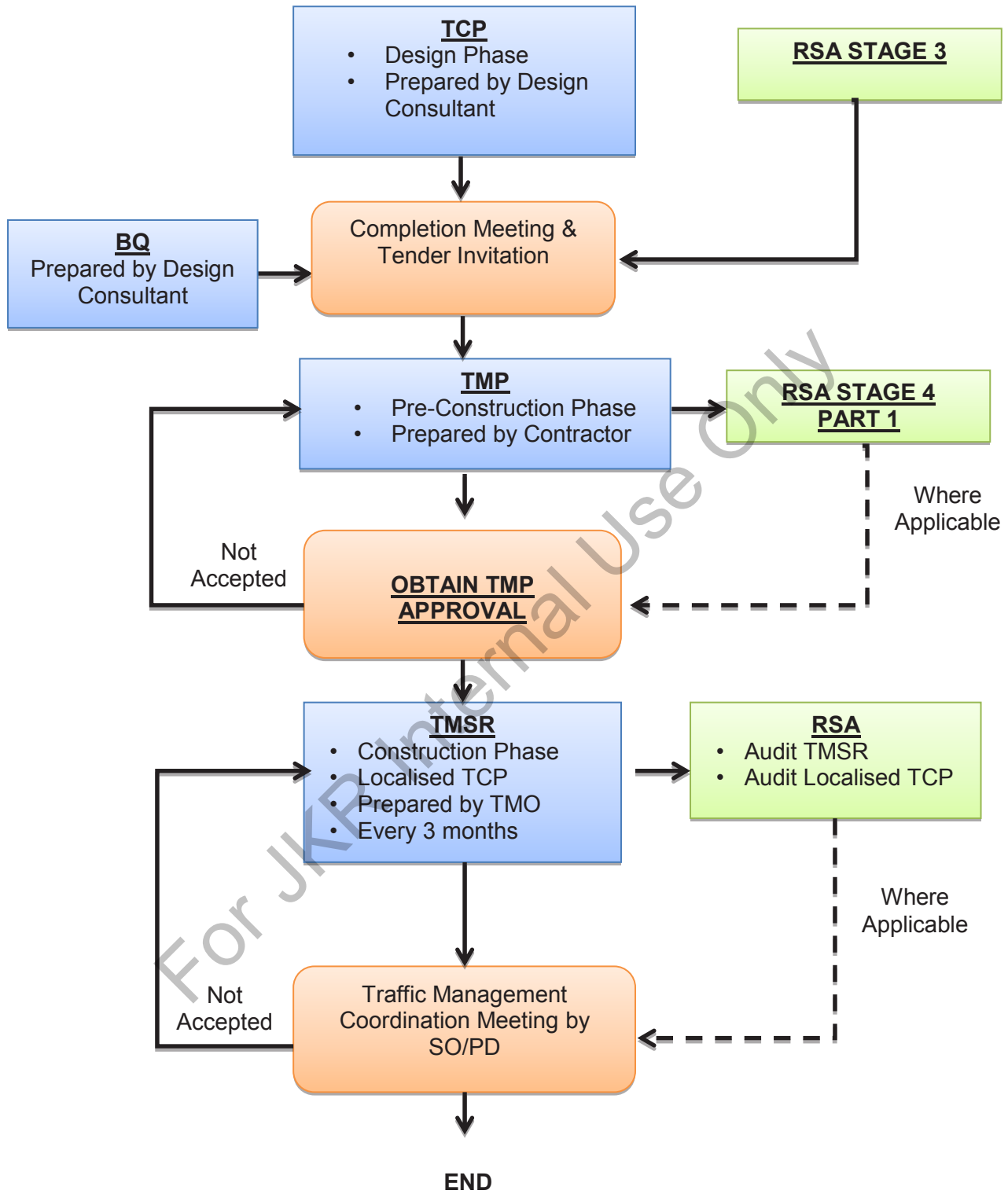

**FIGURE 5.1: SUMMARY OF WORKFLOW FOR DESIGNING A TRAFFIC MANAGEMENT AT WORK ZONES**

## 5.1 Different Types of Traffic Management Plans (TMP)

This Chapter discusses the design of Traffic Management Plans (TMP) including details of the plan, typical layout and adapting typical layout to actual site conditions. The types of Plans to be prepared for a road project are as follows:

- (a) The Traffic Management Plan
- (b) The Traffic Control Plan

The **Traffic Management Plan (TMP)** is a document to be prepared by the Contractor prior to construction works. In this document, the Contractor will spell out his approach to the management of the site during the construction period. Details are as shown below. Most important are the details of planning (refer to Chapter 4) and the Method Statement for the overall project length and duration of the project implementation.

The **Traffic Control Plans (TCPs)** are drawings showing the use of the Traffic Control Devices (TCDs) in the layout of the Work Zones. The TCPs shall be drawn on scaled drawings of existing road layout showing construction sequences, including detours, lane closure and U-turns. The design of the TCPs are detailed out in this chapter.

The TCPs may range from a very detailed plan designed for specific projects, to simply a reference to typical plans. The details of the TCPs depend on the complexity of the project and on the volume of traffic interference brought about by the work activity.

### 5.1.1 The Traffic Management Plan Proposal

Prior to any construction works, the TMP shall be tailored to and implemented by stages according to the construction work sequence. The TMP Proposal should be prepared and must be understood by responsible personnel within one month after site possession.

The Traffic Management Proposal shall consist of the following information:

- (a) Project info
- (b) Detailed construction work programme
- (c) Method statement of traffic management by stages
- (d) Draft media press release (if required)
- (e) Existing road layout including photos (existing facilities, bus stop, lanes, junctions and etc.)
- (f) TCPs that consists of the placement and type of traffic control devices to be used in all work zone involved in the project as well as details about the type of work zone to be implemented in each phase of the work including:
  - (i) Scaled drawings of the work zones
  - (ii) A list of devices selected for installation
  - (iii) Identification of special manpower needs such as flagmen
  - (iv) Endorsement by Professional Engineer.
  - (v) Scaled drawings of construction sequence, including detours, lane closure, U-turns

- (vi) Identification of special needs such as night times delineation, temporary signals, pedestrian crossing facilities, contra flow along dual carriageways
  - (vii) Cross Section to show details of working area
- (g) Other details to be included in the Overall TMP design:
- (i) Existing rules and restrictions on/within the construction area, if any.
  - (ii) The location of work (on roadway, shoulders, or sidewalks)
  - (iii) The number of lanes required for the work activity
  - (iv) Hazards created by the work activity within the recovery area such as boulders, drains, pipe, headwalls, blunt ends of guardrail, and sign supports
  - (v) Anticipated delays during the placement and removal (preferably during low traffic volume periods)
  - (vi) Maximum length of work zone allowed by the road authority
  - (vii) Local traffic generators and attractors

Factors that should be considered in the Preparation of Overall TMP proposal are shown in **TABLE 5.1**.

**TABLE 5.1: FACTORS IN THE PREPARATION OF OVERALL TMP PROPOSAL**

<p><b>Economics and community</b></p> <ul style="list-style-type: none"> <li>- commercial business districts</li> <li>- residential locations</li> <li>- recreation areas</li> <li>- shopping centres</li> <li>- railroad crossings</li> <li>- rural areas</li> </ul>
<p><b>Traffic</b></p> <ul style="list-style-type: none"> <li>- volumes</li> <li>- peak hours, including holiday and special event</li> <li>- pedestrians, bicycles and motorcycle traffic</li> <li>- large vehicles such as trucks and buses</li> <li>- speed of traffic, (Peak and off peak period)</li> <li>- capacity of roadway</li> <li>- traffic signal operation (effect on existing vehicle detectors)</li> <li>- bus stops and taxi stops</li> </ul>
<p><b>Maintenance of work zone site and TCD</b></p> <ul style="list-style-type: none"> <li>- reduced visibility and damage to devices during rain</li> <li>- proper drainage during heavy rain</li> <li>- maintenance of traffic control devices include cleaning and cutting vegetation away from signs</li> </ul>
<p><b>Worker Provisions</b></p> <ul style="list-style-type: none"> <li>- parking of private vehicles</li> <li>- protection near travel way</li> <li>- flagmen</li> <li>- access to each part of work area and break area</li> </ul>

*(Source: 7<sup>th</sup> MRC 2007– Draft on Traffic Management at Work Zones – An Interim Guidelines)*

### 5.1.2 Traffic Control Plans

During the detailed engineering design phase, the Road Design Engineers should design the Traffic Control Plans for the entire project length to suit the sequence of work needed to construct the designed facilities. It will also be used to take-off for the Bill of Quantities.

During construction, TCPs are to be designed by the TMO showing the details of the TCDs to be installed in the Work Zones for any particular location. TCPs should be prepared when there are changes in construction stages/work areas during implementation of traffic management at work zones in the construction area.

The TCPs must be endorsed by the Supervising Engineers and approved by SO/PD/Local Authority (if required) before implementing the TCP at work zones.

Approved TCP must be included in the Traffic Management Safety Report (TMSR) for submission to SO/PD, Supervising Engineers and the Road Safety Auditors.

### 5.1.3 Strategies for Best Design Practice of Traffic Control Plan

Best design practices of Traffic Control Plan are as follow:

- (a) Development of the Traffic Management Plan starts during the planning process. The planning process will generally specify the most appropriate work zone type, the phases of work, and scheduling considerations.
- (b) The work zone length shall be limited to a maximum of 5km in rural condition and 2km in urban condition (not including surcharge work length).
- (c) The spacing between each work zone shall not be less than the maximum work zone length ( as per (b)).
- (d) The number of excavated areas shall not be more than four (4) numbers and each area shall not exceed 200m in length (at any one time) with an interval of not less than 200m.
- (e) Stage sequence of TCP should follow Work Programme of the project.
- (f) Construction staging should be re-examined to determine the complexity of each stage, overlapping of stages, periods or work activities that were overlooked and special problems expected.
- (g) TCP should be designed based on the existing road layout rather than on the completed road layout.
- (h) The geometric standards of the new detour road should, as far as possible, match the existing road. The number of lanes of the detour road must match the number of lanes on the existing road.
- (i) If the existing walkway is closed for construction, temporary walkway should be provided.
- (j) Selection of construction sequence should ensure that there will be two-lane travelling lanes on a single carriageway to be maintained at all time and also cater for stalled vehicles.

- (k) Every detail of TCP shall include the following:
  - (i) Legends that show the explanation of symbols/markings etc used in the TCP.
  - (ii) Notes or explanation of standards and requirements that needs to be adhered during the implementation of the TCP.
  - (iii) Cross-section to show details of working area and carriageway.
- (l) To ensure least disturbance to the road users, the existing number of lanes should be maintained throughout the construction period.
- (m) For existing lighted road, the intensity of the street lighting should be maintained throughout the construction period.
- (n) For single carriageway upgrading works, Work Areas on opposite side of the road at the same location (chainage) are not allowed to proceed simultaneously. They are only allowed at staggered locations.

## 5.2 Design of Work Zones

The design of the TCP must follow the basic concept of a typical work zone. A typical work zone should have the following areas:

- (a) Advance Warning Area
- (b) Transition Area
- (c) Buffer Area
- (d) Work Area
- (e) Termination Area

In this Chapter, each of the “AREA” will be examined for one direction of travel in one time. If the work activity affects more than one direction of travel, the same principles apply to traffic in all directions.

**FIGURE 5.2** illustrates the five areas of a traffic control zone to be discussed in this section.

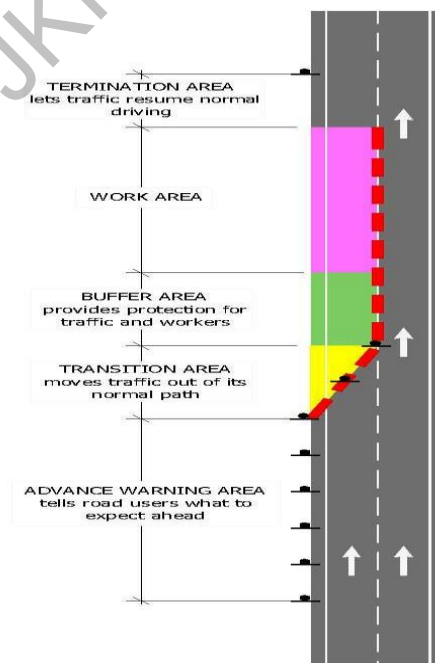

**FIGURE 5.2: AREAS IN WORK ZONE**

### 5.2.1 Advance Warning Area

- (a) An advance warning area is necessary for all traffic control zones because road users need to be made aware that they are approaching the construction area. Before reaching the work area, drivers should be given enough time to alter their driving patterns. The advance warning area may vary from a series of signs with a maximum of 2 km in advance of the work area.
- (b) When the work area, is entirely off the shoulder and the work does not interfere with traffic, an advance warning sign may not be needed. Advance warning sign should be used when any problem including access to the work area or conflicts with the flow of traffic may be anticipated.
- (c) Speed limit during construction shall be reduced gradually with a maximum reduction of 20km/h from the existing speed limit, e.g from 90km/h to 70km/h, 80km/h to 60km/h. The speed reduction should adhere to the final speed limit approved in the overall TMP.
- (d) The advance warning area, from the first sign to the start of the next area, should be long enough to give the motorists adequate time to respond to the changing conditions. For most operations, the advance warning distance requirement for various road types are:
  - (i) 1 km to 2 km for highways
  - (ii) 500m for most rural roadways
  - (iii) at least 250m for urban roadways.

### 5.2.2 Transition Area

- (a) When work is performed within one or more travelled lanes, lane closure(s) is required. In the transition area, traffic is channelized from the normal highway lanes to the path required to move traffic around the work area. The transition area includes the taper transition length.
- (b) Traffic guidance cones may be used for Temporary Diversion.
- (c) The transition area should be clearly visible to drivers. The correct driving path should be clearly marked with channelizing devices and temporary road markings. Existing road markings need to be removed and new yellow temporary road markings placed when they are in conflict with the transition. Road marking arrows are useful in transition areas.
- (d) With moving operations, the transition area moves with the work area. A shadow vehicle may be used to warn and guide traffic into the proper lane.

- (e) A taper is a series of channelizing devices and temporary road markings placed at an angle to move traffic out of its normal path. Three general types of tapers used in traffic control zones are:
- (i) Lane closure tapers are those necessary for closing lanes of moving traffic (sometimes referred to as channelizing tapers)
  - (ii) Contra-flow traffic tapers are those needed to control two-way traffic where traffic required to alternately use a single lane flagman is necessary for this operation
  - (iii) Shoulder closure tapers are those needed to close shoulder areas.

(f) Lane Closure Taper

- (i) If restricted sight distance is a problem, the taper should begin well in advance of the obstruction such as on sharp vertical or horizontal curves.
- (ii) Generally, tapers should be lengthened, not shortened, to increase their effectiveness. Observe traffic to see if the taper is working correctly. Frequent use of brakes and evidence of skid marks is an indication that either the taper is too short or the advance warning is inadequate.

(g) Contra-flow Traffic Taper

The contra-flow traffic taper is used in advance of a work area that occupies part of a two-way road in such a way that the remainder of the road is used alternately by traffic in either direction. In this situation, the function of the taper is not to cause traffic to merge, but rather to resolve the potential head-on conflict. A short taper is used to cause traffic to slow down by giving the appearance of restricted alignment. Drivers then have time to decide whether to proceed cautiously past the workspace or wait for opposing traffic to clear. Flagman on each side with walkie-talkie is usually employed to assign the right-of-way in such situations to manage traffic flow.

(h) Shoulder Closure Taper

When an improved shoulder is closed on a high-speed roadway, it should be treated as a closure of a portion of the roadway, which motorists may expect to use in an emergency. The work area on the shoulder should be preceded by a taper that may be shorter than for lane closures. If the shoulder is being used as a travel lane caused by construction, a lane taper closure should be placed on the shoulder.

### 5.2.3 Buffer Area

- (a) The buffer area is the open or unoccupied space between the transition and work areas. With a moving operation, the buffer area is the space between the shadow vehicle, if one is used, and the work vehicle.
- (b) The buffer area provides a margin of safety for both traffic and workers. If a driver does not see the advance warning or fails to negotiate the transition, a buffer area provides room to stop before the work area. It is therefore important for the buffer area to be free of equipment, workers, materials, and workers' vehicles.
- (c) Place channelizing devices along the edge of the buffer area.

### 5.2.4 Work Area

- (a) The work area is that portion of the roadway, which contains the work activity and is closed to traffic and set aside for exclusive use by workers, equipment, and construction materials. Work areas may remain in fixed locations or may move as work progresses. An empty buffer space may be included at the upstream end. The work area is usually delineated by channelizing devices and shielded by barriers or barriers with hoarding to exclude traffic and pedestrians.
- (b) Conflicts between traffic and the work activity or potential hazards increase as:
  - (i) The work area gets closer to the travelled lanes.
  - (ii) Physical deterrents to normal operation exist, such as uneven pavements, vehicles loading or unloading.
  - (iii) Speed and volume of traffic increases.
  - (iv) The change in travel path gets more complex, shifting traffic a few meters in comparison with shifting traffic across the median and into lanes normally used by opposing traffic.
- (c) Work areas that remain overnight have a greater need for delineation than daytime operations.
- (d) Guidelines
  - (i) Use traffic control devices to make the work area clearly visible to traffic.
  - (ii) Place channelizing devices between the work area and the travelled way with spacing and lateral clearance as shown in **TABLE 5.3**. Devices placed on a tangent (along the work area) to keep traffic out of a closed lane should be spaced in accordance with the extent and type of activity, the speed limit, vertical and horizontal alignment such that it is clearly visible that the lane is closed. For low-speed roadways, a closer spacing may be adopted.

- (iii) Provide a safe entrance and exit for construction vehicles which should be manned by flagman.
- (iv) Protect mobile and moving operations with adequate warning on the work and/or shadow vehicles.
- (v) Flashing lights and flags should be considered on work vehicles exposed to traffic.
- (vi) Plastic barrier shall be used at excavation work area if depth is less than 1m and must be interlocked.
- (vii) Concrete barrier shall be used at excavation work with depth 1m or more.

#### **5.2.5 Termination Area**

- (a) The termination area provides a short distance for traffic to clear the work area and to return to the normal traffic lanes. It extends from the downstream end of the work area to the "PEMBINAAN TAMAT" sign. A downstream taper may be placed within the termination area.
- (b) For some minor work operations, such as single location utility or maintenance repair, it may not be necessary to display a sign as it will be obvious to drivers that they had passed the work area.
- (c) There are occasions where the termination area could include a transition. For example, if a taper were used to shift traffic into opposing lanes around the work area, then the termination area should have a taper to shift traffic back to its normal path. This taper would then be in the transition area for the opposing direction of traffic. It is advisable to use a buffer space between the tapers for opposing traffic.
- (d) Avoid 'gaps' in the traffic control that may falsely indicate to drivers that they had passed the work zone. For example, if the work area includes intermittent activity throughout a 1 kilometre section, the drivers should be reminded periodically that they are still in the work area.

**TABLE 5.2: DISTANCE OF WORK ZONE**

ROAD CLASSIFICATION	SPEED PROFILE	DISTANCE OF WORK ZONE (m)						WORK AREA	TERMINATION AREA (MIN.)
		ADVANCE WARNING AREA	TRANSITION AREA	BUFFER AREA	WORK AREA	TERMINATION AREA			
URBAN	Low Speed (< 60 kph)	250	100	100	50		15		
	High Speed (> 60 kph)	400	150	150	100	30			
	Low Speed (< 70 kph)	350	100	100	110	15			
RURAL	High Speed (> 70 kph)	500	150	150	150	30			
	Low Speed (< 90 kph)	1000	250	250	150	15			
	High Speed (> 90 kph)	2000	300	300	220	30			

\*The road category and its functions can be referred to the latest Arahan Teknik (Jalan) ATJ 8/86: A Guide on Geometric Design of Roads

**TABLE 5.3: SPACING OF DEVICES**

TRAFFIC CONTROL DEVICES	WORK ZONE						SPACING OF DEVICES
	ADVANCE WARNING AREA	TRANSITION AREA	BUFFER AREA	WORK AREA	TERMINATION AREA		
Traffic Guidance Cone	-	-	/	/	-	15 m	
Traffic Guidance Cone	-	/	-	-	-	5 m	
Traffic Super Cone	-	/	-	-	-	5 m	
Plastic Barrier	-	/	/	/	-	Lateral clearance to excavate depth - 1 m	
Concrete Barrier	-	/	/	/	-	Interlocked Lateral clearance to excavate depth - 0.6 m	
Wooden Post for Delineator String	-	/	/	/	-	3 m	
Flashing Light (Blinker)	-	/	/	/	-	Straight - 30 m c/c Taper or curve - 10 m c/c	

## 6.0 TYPICAL LAYOUTS OF THE TRAFFIC MANAGEMENT PLAN

### 6.1 General

This chapter discusses the typical layout of the traffic management plan in work zone. Each traffic control area in one work zone is different, with variables such as speed, volume, location of work, pedestrians, and intersections changing the needs for each area. The goal of work zone traffic control is safety, and the key factor in effective traffic control in work zones is application of proper judgements. The examples in this chapter are guides showing how best to apply the standards.

For the purpose of standardization, ease of strategy identification and design, it is proposed that the Work Zone types are divided into two, i.e.:

- (a) Traffic Category , and
- (b) Construction Duration Category

#### 6.1.1 The Traffic Category

The Traffic Category will determine the length of the work zone. These are illustrated in **TABLE 4.2, FIGURE 6.1A** and **6.1B**.

#### 6.1.2 The Construction Duration Category

The Construction Duration category will determine the type of the Traffic Control Devices. These are illustrated in **TABLE 6.2, FIGURE 6.2A** and **FIGURE 6.2B**.

**TABLE 6.2: THE CONSTRUCTION DURATION CATEGORIES**

CONSTRUCTION DURATION CATEGORIES	
CLASSIFICATION	DURATION
Temporary Lane closure *Flagmen are always required during temporary lane closure	< 1 Day
Short Term Diversion	> 1 Day < 1 Month
Long Term Diversion	> 1 Month

(Source: 7<sup>th</sup> MRC 2007– Draft on Traffic Management at Work Zones – An Interim Guidelines)

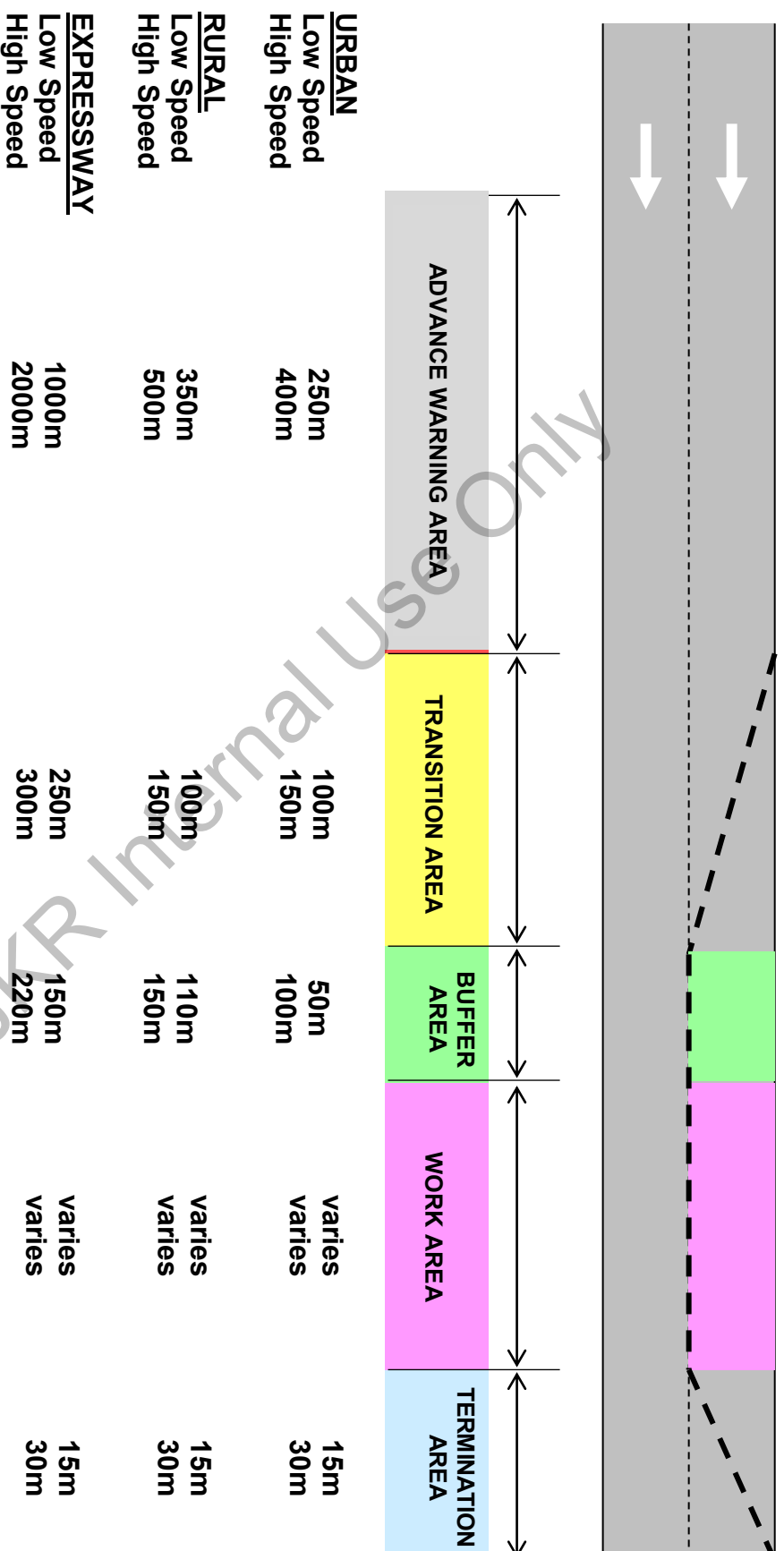

\*The road category and its functions can be referred to the latest Arahan Teknik (Jalan) ATJ 8/86: A Guide on Geometric Design of Roads

FIGURE 6.1A: LENGTH OF AREAS IN WORK ZONE FOR TEMPORARY LANE CLOSURE

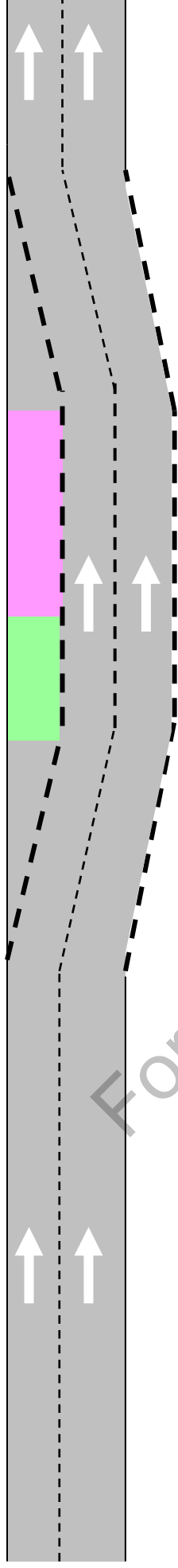

	ADVANCE WARNING AREA	TRANSITION AREA	BUFFER AREA	WORK AREA	TERMINATION AREA
<b>URBAN</b>					
Low Speed	250m	100m	50m	varies	15m
High Speed	400m	150m	100m	varies	30m
<b>RURAL</b>					
Low Speed	350m	100m	110m	varies	15m
High Speed	500m	150m	150m	varies	30m
<b>EXPRESSWAY</b>					
Low Speed	1000m	250m	150m	varies	15m
High Speed	2000m	300m	220m	varies	30m

\*The road category and its functions can be referred to the latest Arahan Teknik (Jalan) ATJ 8/86: A Guide on Geometric Design of Roads

\*Taper length of termination area is half of the termination area based on lateral shift of 1m/s

**FIGURE 6.1B: LENGTH OF AREAS IN WORK ZONE FOR ROAD DIVERSION**

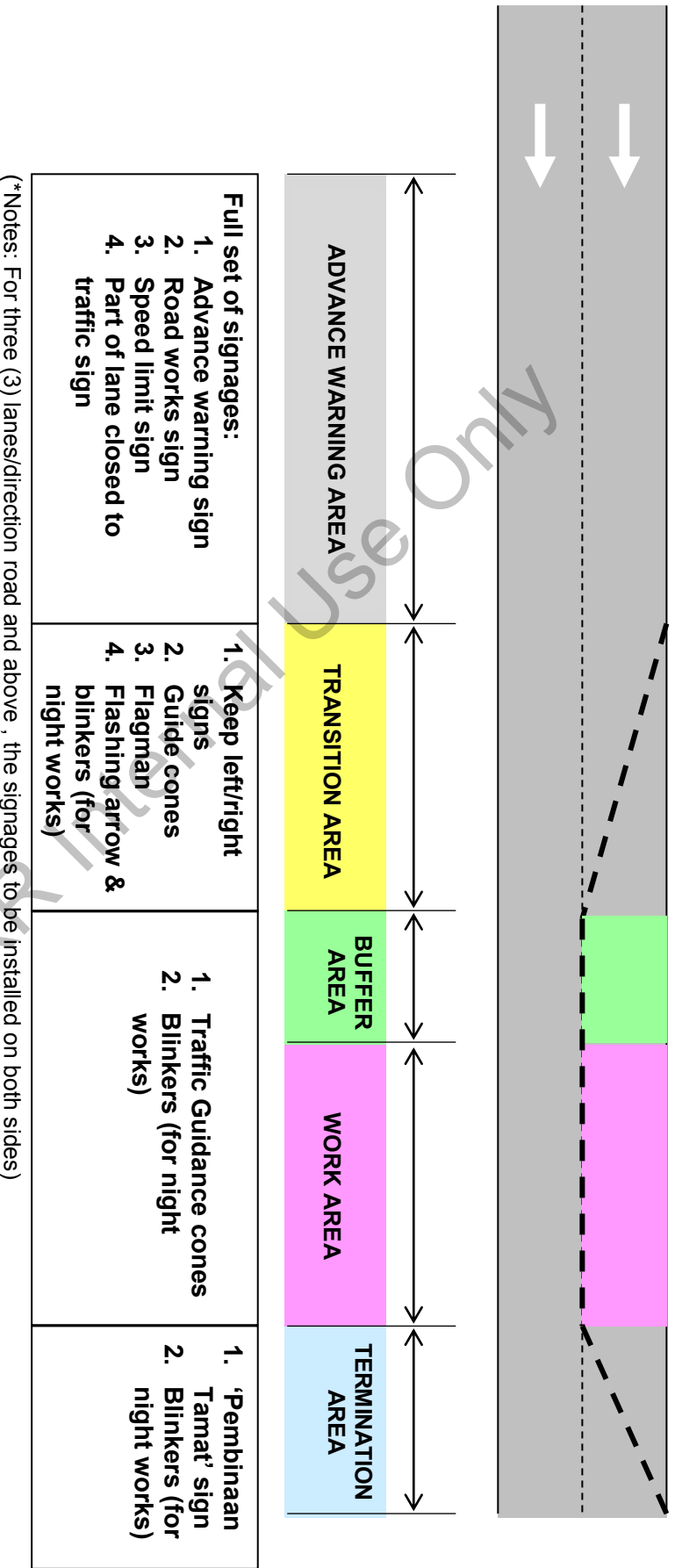

**FIGURE 6.2A: THE CHOICE OF TRAFFIC CONTROL DEVICES (TEMPORARY LANE CLOSURE)**

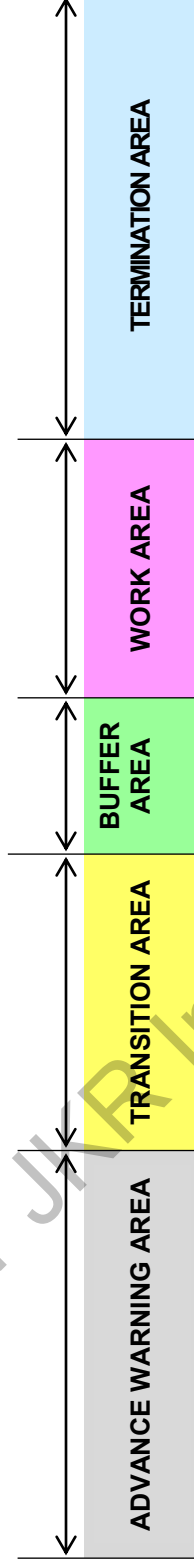
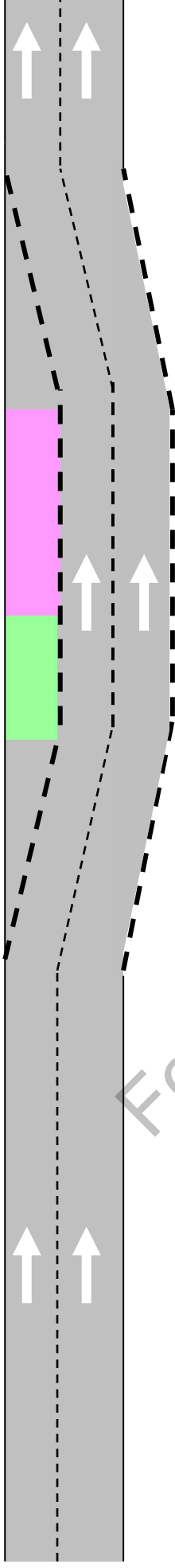

**SHORT TERM  
DIVERSION**

<b>Full set of signages:</b> 1. Advance warning sign 2. Road works sign 3. Speed limit signs 4. Detour sign	1. Keep left/right signs 2. Plastic barriers 3. Flashing arrow & blinkers	1. Road works signs (work area) & speed signs 2. Plastic/concrete barriers 3. Blinkers	1. Chevron delineator signs 2. Plastic barriers 3. Flashing arrow & blinkers	'PEMBINAAN TAMAT' sign
-------------------------------------------------------------------------------------------------------------------------	---------------------------------------------------------------------------------	----------------------------------------------------------------------------------------------	------------------------------------------------------------------------------------	------------------------

**LONG TERM  
DIVERSION**

<b>Full set of signages:</b> 1. Advance warning sign 2. Road works sign 3. Speed limit signs 4. Detour sign	1. Keep left/right signs 2. Plastic barriers 3. Flashing arrow & blinkers 4. Delineator on barriers/delineator string	1. Road works signs (work area) & speed signs 2. Plastic/concrete barriers 3. Blinkers & delineator on barriers/delineator string	1. Chevron delineator signs 2. Plastic barriers 3. Flashing arrow & blinkers 4. Delineator on barriers/delineator string	'PEMBINAAN TAMAT' sign
-------------------------------------------------------------------------------------------------------------------------	--------------------------------------------------------------------------------------------------------------------------------	-----------------------------------------------------------------------------------------------------------------------------------------	-----------------------------------------------------------------------------------------------------------------------------------	------------------------

(\*Notes: For three (3) lanes/direction road and above , the signages to be installed on both sides)

**FIGURE 6.2B: THE CHOICE OF TRAFFIC CONTROL DEVICES (ROAD DIVERSION)**

## 6.2 Sign Arrangements

It is the intention of the Manual to standardize the application of the temporary signs in the Work Zones. This is to ensure that drivers' familiarize and comply with the TMP proposal. It is recommended that a uniform arrangement of signs be adopted throughout the work area. The proposed arrangement of signs is in **FIGURE 6.3**. Advance warning area length, taper length and spacing of devices are given in **TABLE 5.3**.

The detailed signing of each area is as follows:

### 6.2.1 Advance Warning Area (See FIGURE 6.4)

(a) Sign 1 – Advance Warning Sign

This sign gives an advance warning to the motorists of a work area ahead. It should also identify the Road Authority responsible for the work. This is usually a “worded” sign. This sign should be installed as the first sign of advance warning area. The distance from Transition Area is equal to length of the advance warning area.

(b) Sign 2 – Road Works Sign

This sign also provides advance warning to the motorists of a work area ahead. This is usually a “symbol” sign. This sign should be installed as the second sign, that is after the identification sign.

(c) Sign 3 – Speed Limit Sign

This is the Speed sign indicating the first “step-down” speed for the motorists. The speed step-down should not exceed 20km/hr. This sign should be installed as the third sign that is after Information sign.

(d) Sign 4 – Part of Lane Closed to Traffic Sign/ Detour Sign (Symbol Only)

This sign provides information to the motorists of what to expect ahead and what manoeuvres he will need to make. This is usually a “symbol” sign. This sign should be installed as the fourth sign that is after Speed sign. Part of lane closed to traffic sign is for lane closure whereas detour sign is for road diversion.

(e) Sign 5 – Speed Limit Sign

This is the Speed sign indicating the second “step-down” speed for the motorists. This sign should be installed as fifth sign that is after sign 4.

### **6.2.2 Transition Area (See FIGURE 6.5).**

(a) Sign 6,7 & 8 – Keep Left/Right Sign

These signs should be placed at the Transition Area. Sign 6 should be installed at the beginning of the Transition Area. Sign 7 is placed at the middle of the Transition Area. Sign 8 is placed at the end of the Transition Area. It is advisable to install all the Keep Left/Right Sign on high posts.

\* The number of “Keep Left/Right Sign” in the Transition Area can be more if the conditions at the site demand it.

### **6.2.3 Buffer And Work Area (See FIGURE 6.6).**

(a) Sign 9 & 11 – Speed Limit Sign

This is the Speed Limit Sign informing the motorists the safe speed to drive through the Work Area. This sign 9 should be installed at the beginning of the Work Area. It is advisable to install the Speed Limit Sign on high posts. This sign is repeated for Sign 11. This sign should be placed about 100m – 200m after Sign 10.

(b) Sign 10 & 12 – Road Works Sign (Work Area)

This is the Road Works Sign (Work Area) reminding the motorists driving through the Work Area. This sign 10 should be installed at 50m – 100m into the Work Area. It is advisable to install this sign on high posts. This sign is repeated for Sign 12. This sign should be placed about 100m – 200m after Sign 11.

\* The number of “Speed Limit Sign” and “Road Works Sign (Work Area)” in the Work Area can be more if the work area is longer and the conditions at the site warrant it. These signs should be installed alternately at 200m spacing.

### **6.2.4 Termination Area (See FIGURE 6.7).**

(a) Sign 13,14 & 15 – Chevron Delineator Sign

These signs should be placed in the Termination Area upon the occurrence of road diversion. Sign 13 should be installed at the beginning of the Termination Area where the transition begins. Sign 14 is placed at the middle of the taper. Sign 15 is placed at the end of the taper. It is advisable to install all the Chevron Delineator sign on high posts.

(b) Sign 16 – “PEMBINAAN TAMAT” Sign

Installed at the point beyond the Termination Area where traffic is no longer affected.

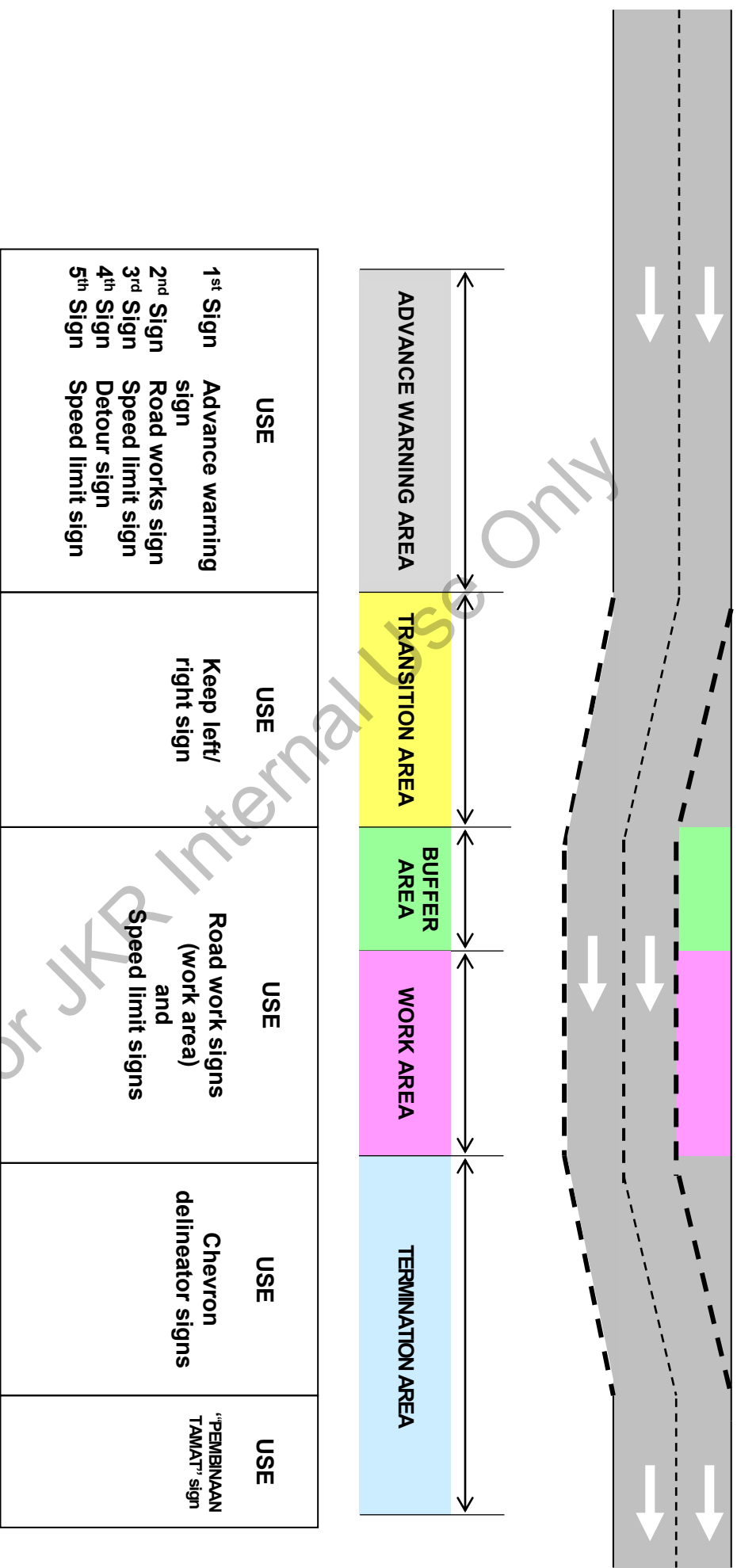

(\*Notes: For three (3) lanes/direction road and above , the signages to be installed on both sides)

FIGURE 6.3: SIGN ARRANGEMENTS

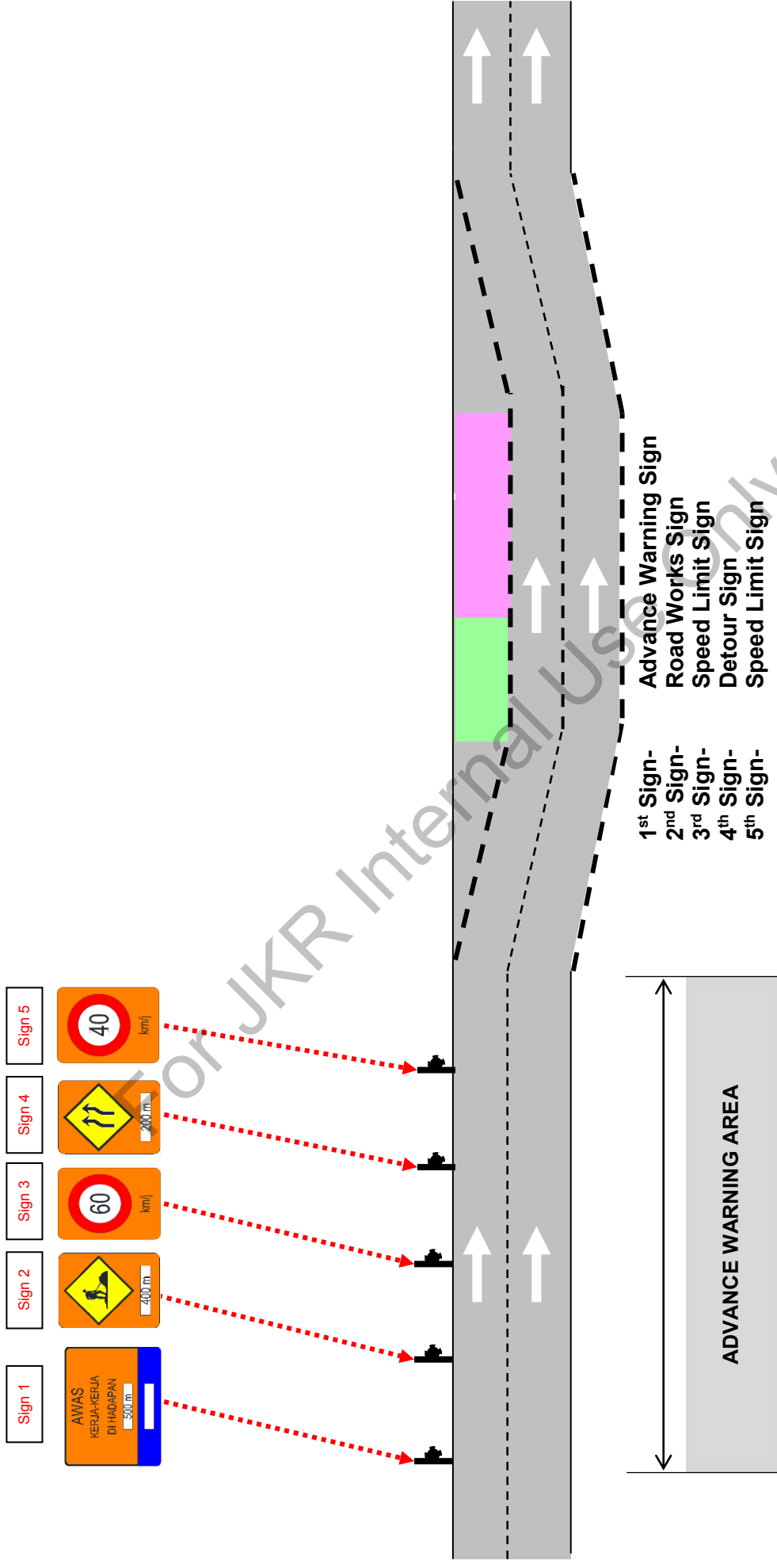

(\*Notes: For three (3) lanes/direction road and above, the signages to be installed on both sides)

**FIGURE 6.4: SIGN ARRANGEMENTS FOR ADVANCE WARNING AREA**

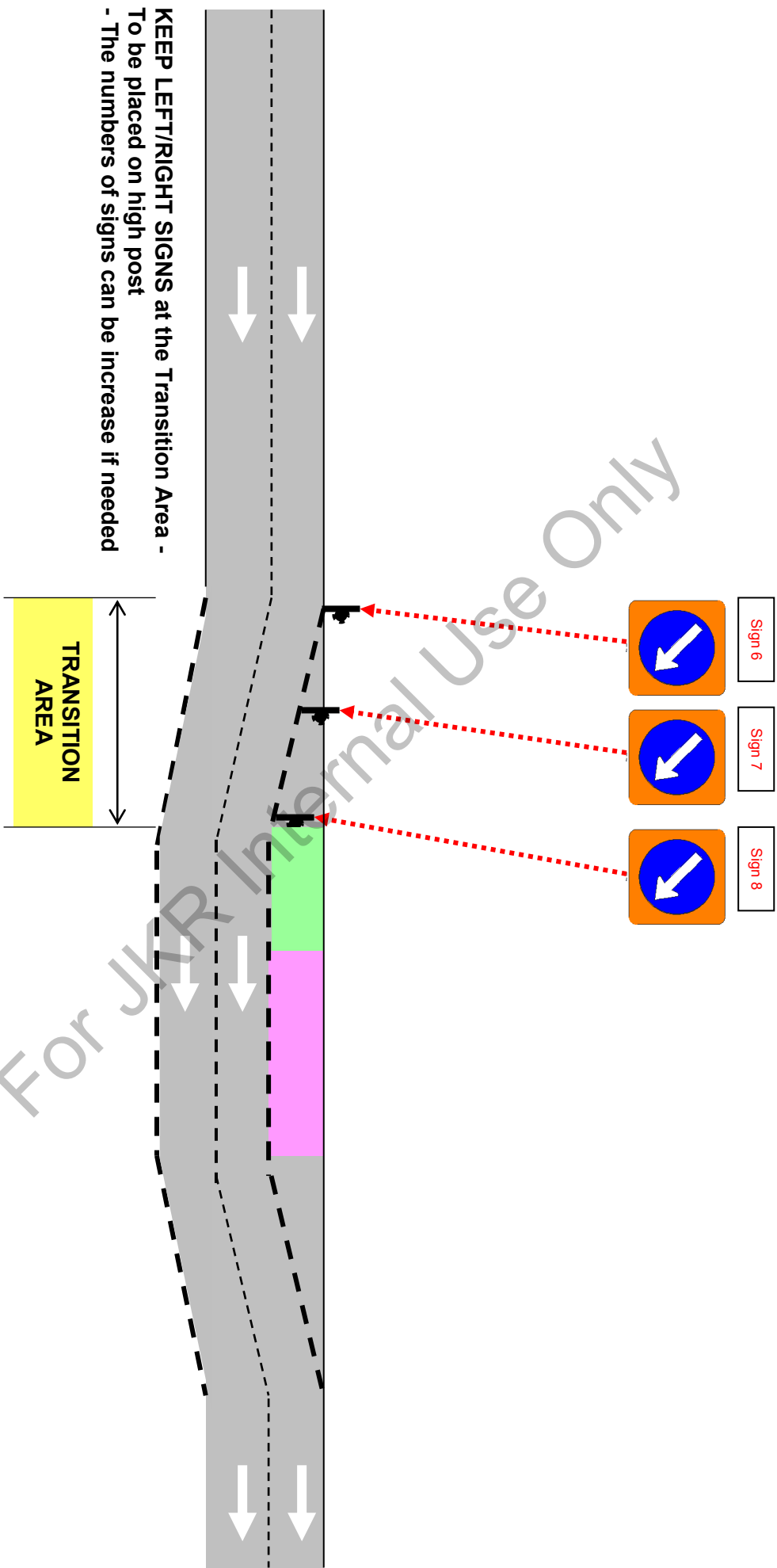

(\*Notes: For three (3) lanes/direction road and above , the signages to be installed on both sides)

**FIGURE 6.5: SIGN ARRANGEMENTS FOR TRANSITION AREA**

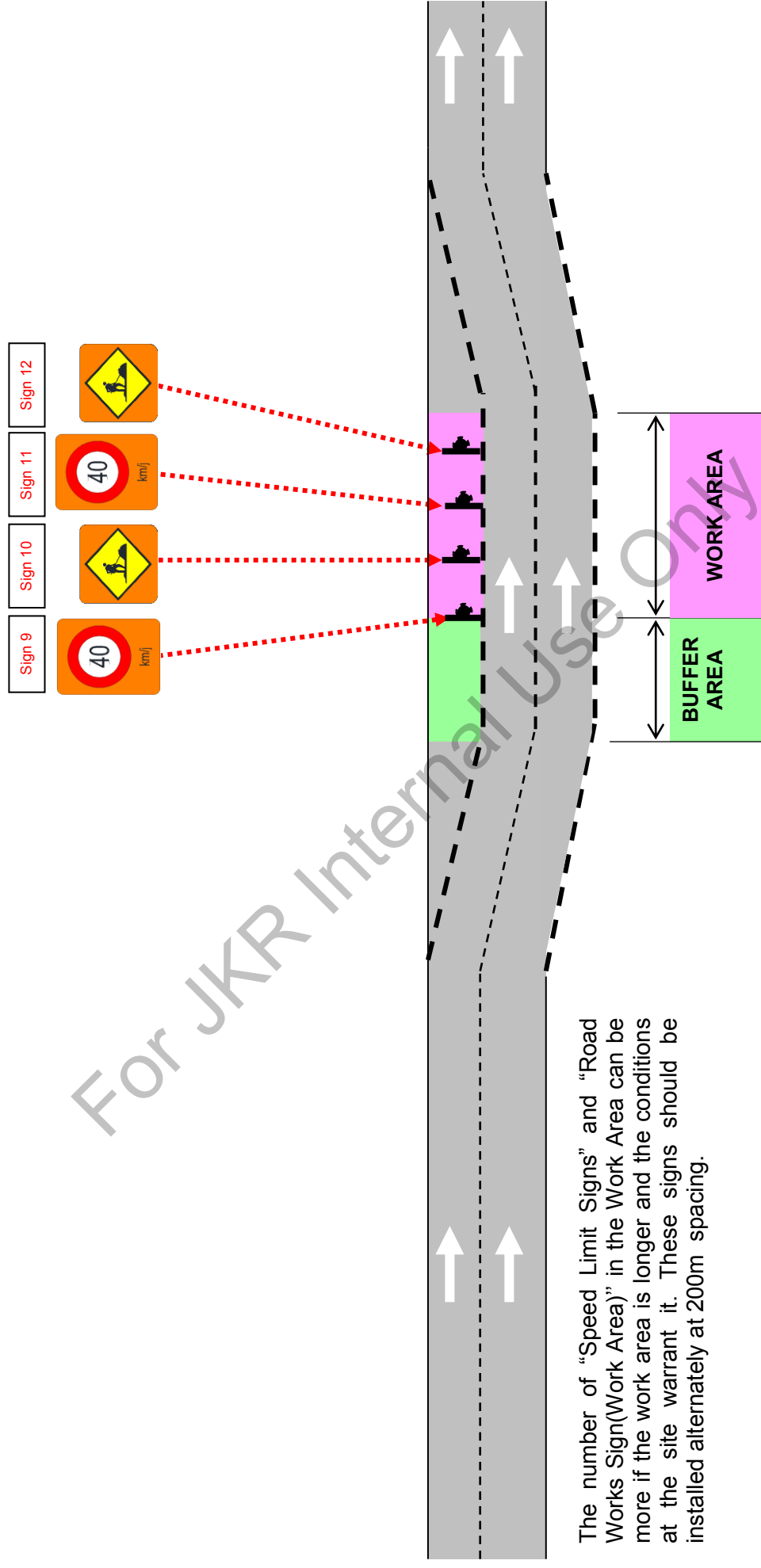

The number of "Speed Limit Signs" and "Road Works Sign(Work Area)" in the Work Area can be more if the work area is longer and the conditions at the site warrant it. These signs should be installed alternately at 200m spacing.

(\*Notes: For three (3) lanes/direction road and above , the signages to be installed on both sides)

**FIGURE 6.6: SIGN ARRANGEMENTS FOR WORK AREA**  
45

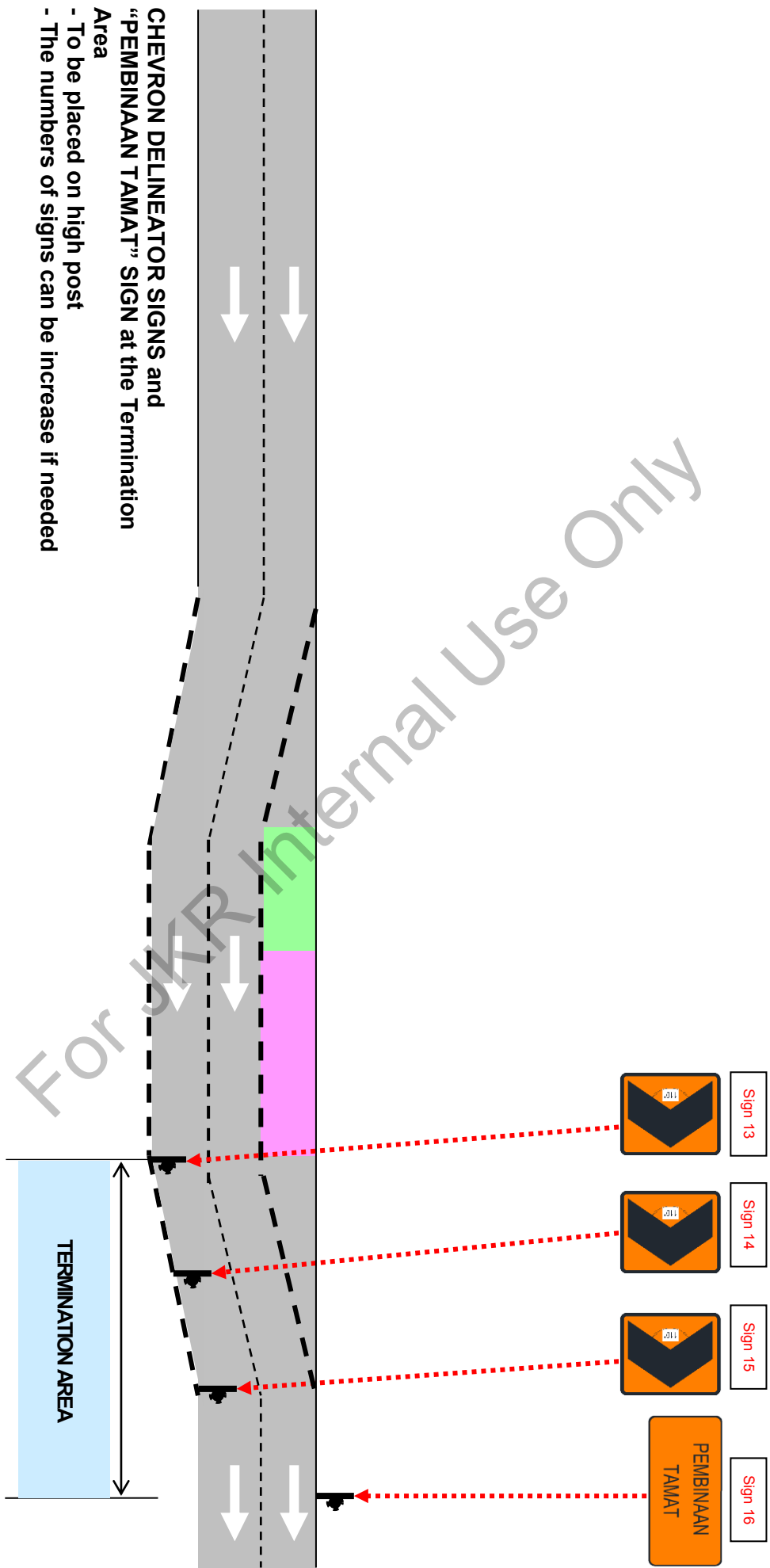

(\*Notes: For three (3) lanes/direction road and above , the signages to be installed on both sides)

**FIGURE 6.7: SIGN ARRANGEMENTS FOR TERMINATION AREA**

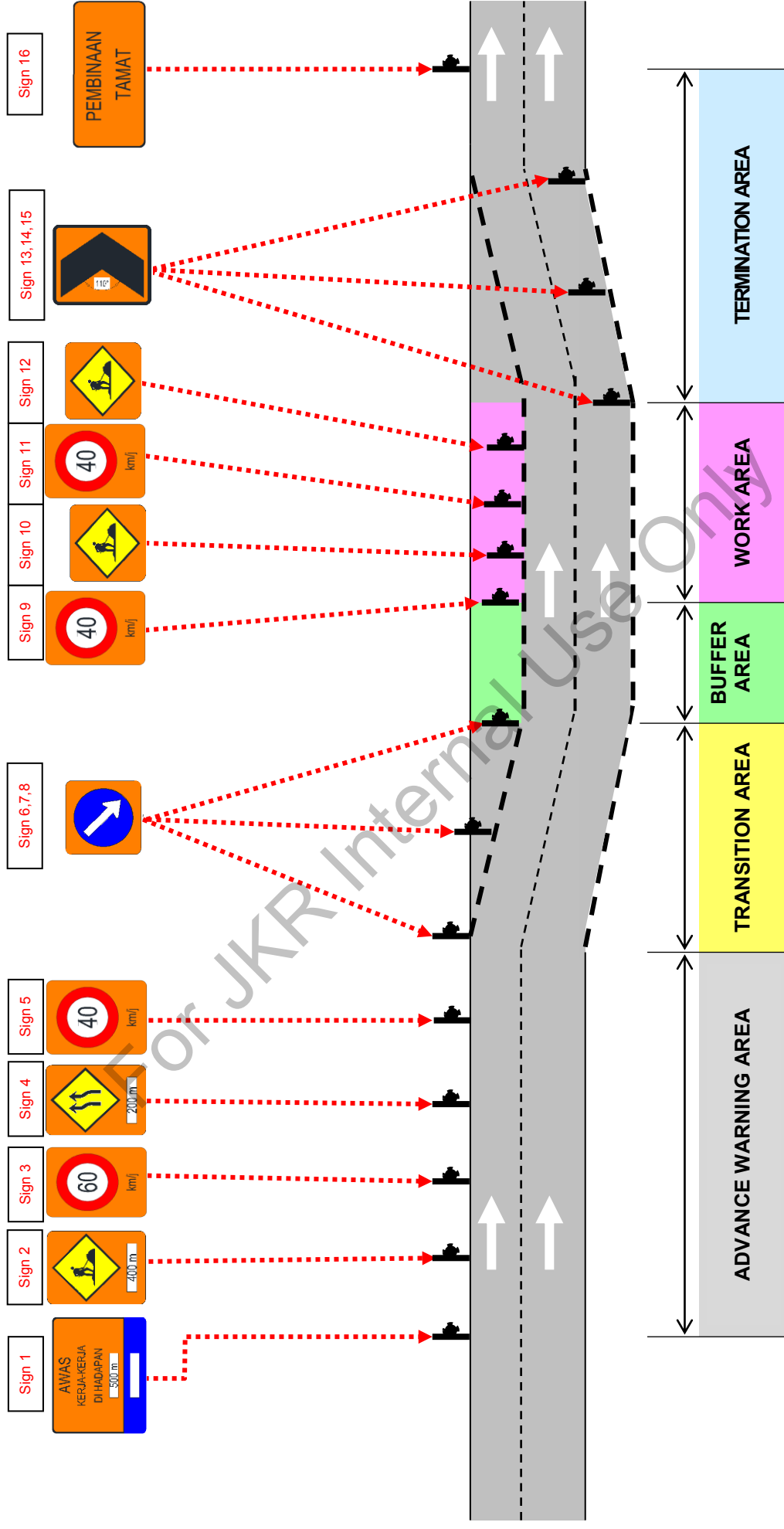

(\*Notes: For three (3) lanes/direction road and above, the signages to be installed on both sides)

**FIGURE 6.8: OVERALL SIGN ARRANGEMENTS FOR THE TYPICAL WORK ZONE**

### 6.3 Modification of Typical Layouts

Plans contained in the Guidelines are called “typical applications.” In this respect, they represent the layouts for the general situations found in the field. When unusual conditions are found, the typical layouts must be adapted to the particular roadway and worksite configuration. Furthermore, these typical layouts are minimum requirements. When needed, either additional device may be used to supplement the layout, or the sign spacing and taper lengths can be increased to give drivers additional response time or shortened for low-speed situations. When difficult situations or unusually hazardous conditions are encountered, a higher-type treatment than that shown as typical may be required.

The types of modifications that may be desirable or needed include the following:

- (a) Additional devices
  - (i) Temporary Signage
  - (ii) Temporary Road Marking
  - (iii) Temporary Management Equipment
- (b) Upgrading of devices
  - (i) improved pavement markings or raised pavement markers
  - (ii) larger signs
  - (iii) higher type channelizing devices
  - (iv) barriers in place of channelizing devices
  - (v) variable message signs
- (c) Improved geometrics at detours or crossovers
- (a) Increased distances
  - longer work zone
- (b) Lighting and Delineation
  - (i) Flashing lights (Blinker)
  - (ii) Beacon Light
  - (iii) Flashing Arrow
  - (iv) Chevron Light
  - (v) Traffic Baton Light used by Flagman
  - (vi) Delineator string
  - (vii) Delineator on Barrier
  - (viii) Temporary Lighting

### 6.4 Consideration of Parameters of Typical Layouts

The following list defines the basic parameters and the range of their characteristics:

- (a) Type of facility
  - (i) two-lane
  - (ii) multilane, undivided
  - (iii) multilane, divided
  - (iv) intersection
  - (v) interchange

- (b) Regional and traffic characteristics
  - (i) rural/urban
  - (ii) low speed/high speed
  - (iii) low volume/high volume
- (c) Work activity duration
  - (i) short or long term
  - (ii) slow or fast moving
  - (iii) intermittent or continuous
- (d) Worksite location
  - (i) in right-of-way
  - (ii) on shoulder
  - (iii) in road
- (e) Closure configuration
  - (i) shoulder closed
  - (ii) lane or lanes closed
  - (iii) shoulder used as travel lane
  - (iv) roadway closed
  - (v) crossover and/or contra flow
  - (vi) on-site detour (bypass)
  - (vii) off-site detour

When making modifications to the typical solutions it is best to establish a set of plans, which covers the range of conditions commonly found rather than a plan for every possible combination of parameter values.

## **6.5 Considerations to Modifying the Typical Layouts**

Typical applications may be modified to suit the conditions of a particular work area.

On many of the typical applications, the existing pavement markings have been either marked or changed to indicate those that should be modified for long-term projects. If the project is short-term, such as 1-day maintenance operations, the pavement markings will not need to be removed and replaced although guidance should be provided with other channelizing devices.

## **6.6 Typical Application Layouts**

**FIGURES 6.8 to 6.12** show typical traffic control devices that are required for various types of Work Zones.

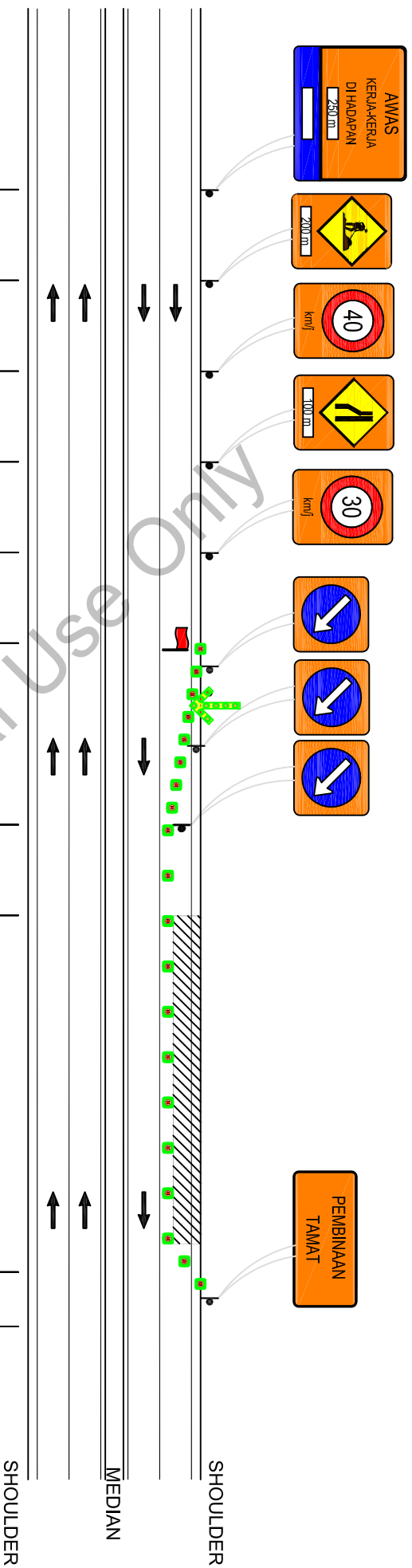

**LEGEND**

	TRAFFIC FLOW
	TRAFFIC GUIDANCE CONE
	FLAGMAN
	WORK AREA

**NOTES**

1. TRAFFIC GUIDANCE CONE SHALL BE INSTALLED EVERY 15m c/c AT STRAIGHT AND 5m c/c AT TAPER OR CURVE.
2. FLASHING LIGHT (BLINKERS) SHALL BE INSTALLED EVERY 30m c/c AT STRAIGHT AND 10m c/c AT TAPER OR CURVE.
3. FOR NIGHT WORKS, THE CONTRACTOR SHALL INSTALL A RELIABLE FLOOD LIGHT SYSTEM (ANTI-GLARE FEATURE).
4. PROVIDE A SAFE ENTRANCE AND EXIT FOR CONSTRUCTION VEHICLES WHICH SHALL BE MANNED BY FLAGMAN.

SPEED LIMIT (kph)	1ST REDUCTION SPEED (kph)	2ND REDUCTION SPEED (kph)
90	70	50
80	60	40
70	50	30
60	40	30
50	30	-

**FIGURE 6.8: TEMPORARY LANE CLOSURE ON SLOW LANE OF DUAL CARRIAGEWAY (URBAN LOW SPEED)**

Scale : Not to scale



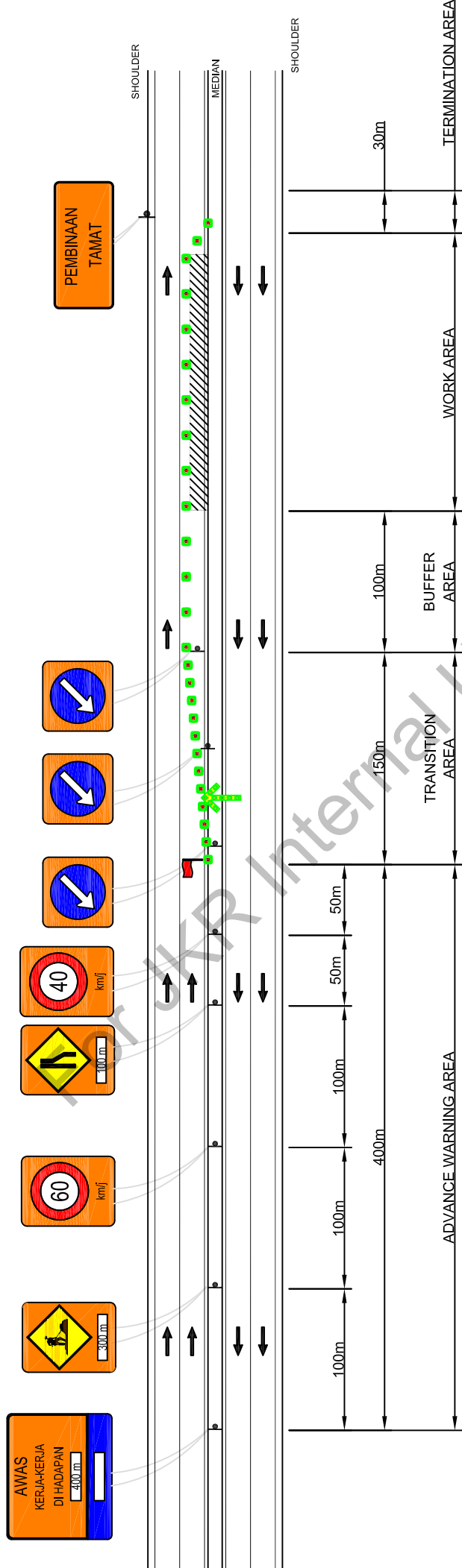

SPEED LIMIT (kph)	1ST REDUCTION SPEED (kph)	2ND REDUCTION SPEED (kph)
90	70	50
80	60	40
70	50	30
60	40	30
50	30	-

**NOTES**

1. TRAFFIC GUIDANCE CONE SHALL BE INSTALLED EVERY 15m c/c AT STRAIGHT AND 5m c/c AT TAPER OR CURVE.
2. FLASHING LIGHT (BLINKERS) SHALL BE INSTALLED EVERY 30m c/c AT STRAIGHT AND 10m c/c AT TAPER OR CURVE.
3. FOR NIGHT WORKS, THE CONTRACTOR SHALL INSTALL A RELIABLE FLOOD LIGHT SYSTEM (ANTI-GLARE FEATURE).
4. PROVIDE A SAFE ENTRANCE AND EXIT FOR CONSTRUCTION VEHICLES WHICH SHALL BE MANNED BY FLAGMAN.

**LEGEND**

	TRAFFIC FLOW
	TRAFFIC GUIDANCE CONE
	FLAGMAN
	WORK AREA

FIGURE 6.9: TEMPORARY LANE CLOSURE ON FAST LANE OF DUAL CARRIAGEWAY (URBAN HIGH SPEED)



Scale : Not to scale

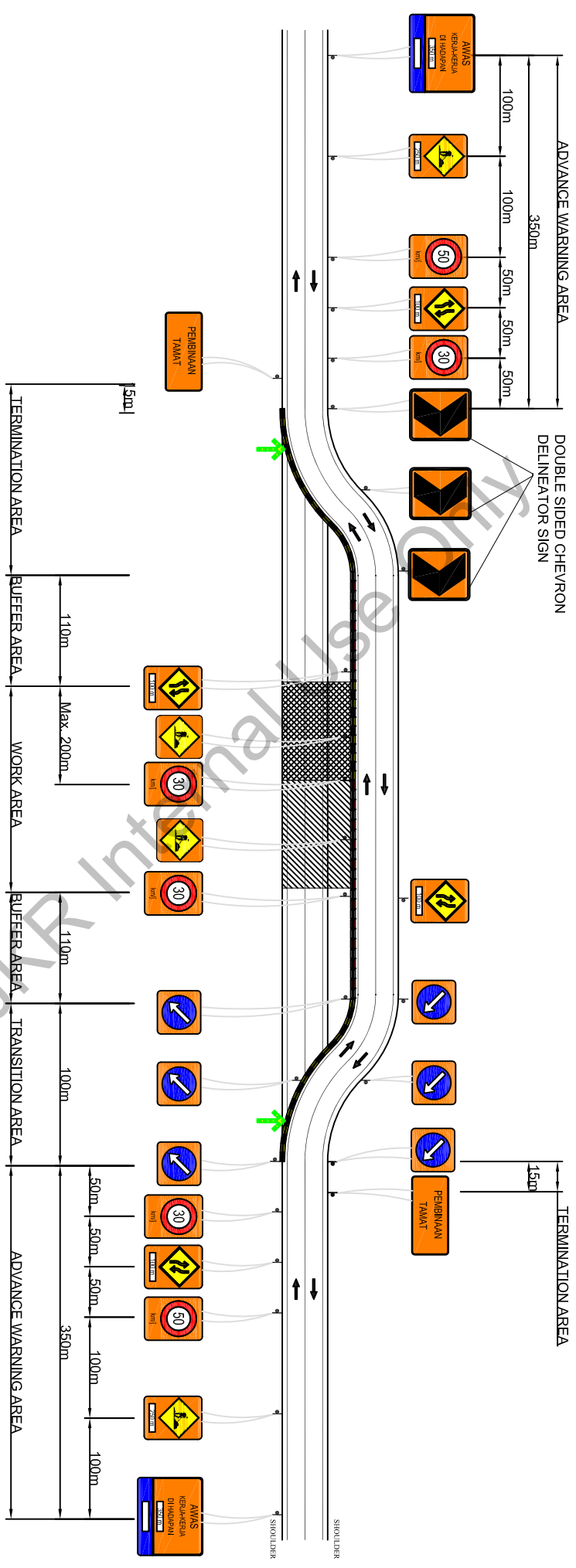

**LEGEND**

	TRAFFIC FLOW
	FLASHING ARROW
	PLASTIC BARRIER
	CONCRETE BARRIER
	WORK AREA
	EXCAVATION AREA WITH DEPTH 1m OR MORE

- NOTES**
1. BARRIERS SHALL BE CONTINUOUS ALONG THE WORK AREA.
  2. PLASTIC HOARDING SHALL BE INSTALLED IF THERE ARE ANY HEAVY MACHINERIES OR ACTIVITIES WITHIN THE CONSTRUCTION AREA.
  3. FLASHING LIGHT (BUNKERS) SHALL BE INSTALLED EVERY 30m dc AT STRAIGHT AND 10m dc AT TAPER OR CURVE.
  4. FOR NIGHT WORKS, THE CONTRACTOR SHALL INSTALL A RELIABLE FLOOD LIGHT SYSTEM (ANTI-GLARE FEATURE).
  5. PROVIDE A SAFE ENTRANCE AND EXIT FOR CONSTRUCTION VEHICLES WHICH SHALL BE MANNED BY FLAGMAN.

SPEED LIMIT (kph)	1ST REDUCTION SPEED (kph)	2ND REDUCTION SPEED (kph)
90	70	50
80	60	40
70	50	30
60	40	30
50	40	30

FIGURE 6.10: LONG TERM WORKS IN WHICH TRAFFIC IS DIVERTED (RURAL LOW SPEED)

Scale : Not to scale



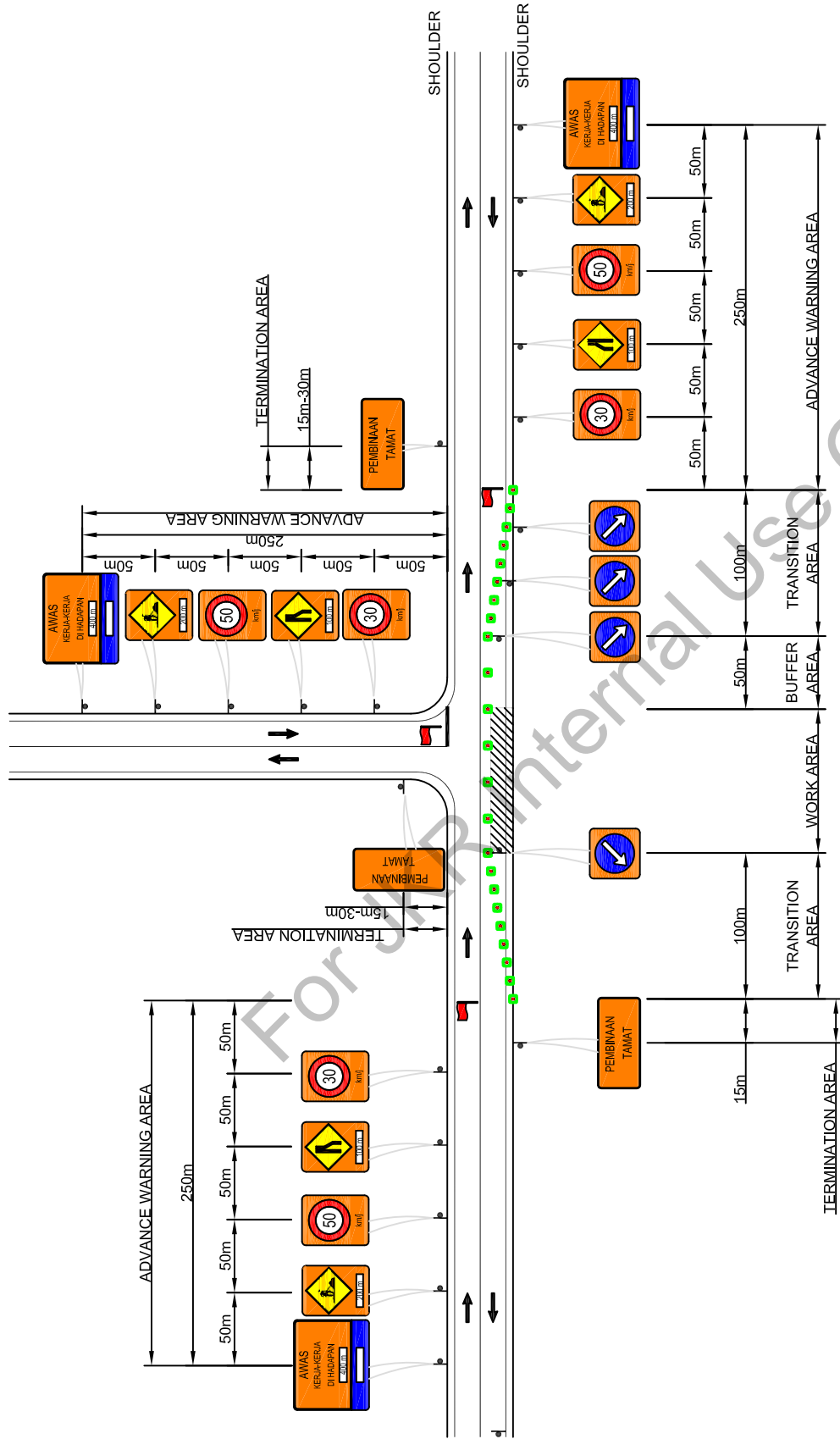

LEGEND

	TRAFFIC FLOW
	TRAFFIC GUIDANCE CONE
	FLAGMAN
	WORK AREA

NOTES

1. TRAFFIC GUIDANCE CONE SHALL BE INSTALLED EVERY 15m c/c AT STRAIGHT AND 5m c/c AT TAPER OR CURVE.
2. FLASHING LIGHT (BLINKERS) SHALL BE INSTALLED EVERY 30m c/c AT STRAIGHT AND 10m c/c AT TAPER OR CURVE.
3. FOR NIGHT WORKS, THE CONTRACTOR SHALL INSTALL A RELIABLE FLOOD LIGHT SYSTEM (ANTI-GLARE FEATURE).
4. PROVIDE A SAFE ENTRANCE AND EXIT FOR CONSTRUCTION VEHICLES WHICH SHALL BE MANNED BY FLAGMAN.

SPEED LIMIT (kph)	1ST REDUCTION SPEED (kph)	2ND REDUCTION SPEED (kph)
90	70	50
80	60	40
70	50	30
60	40	30
50	30	-

FIGURE 6.11: TEMPORARY LANE CLOSURE AT INTERSECTION OF SINGLE CARRIAGEWAY (URBAN LOW SPEED)



Scale : Not to scale

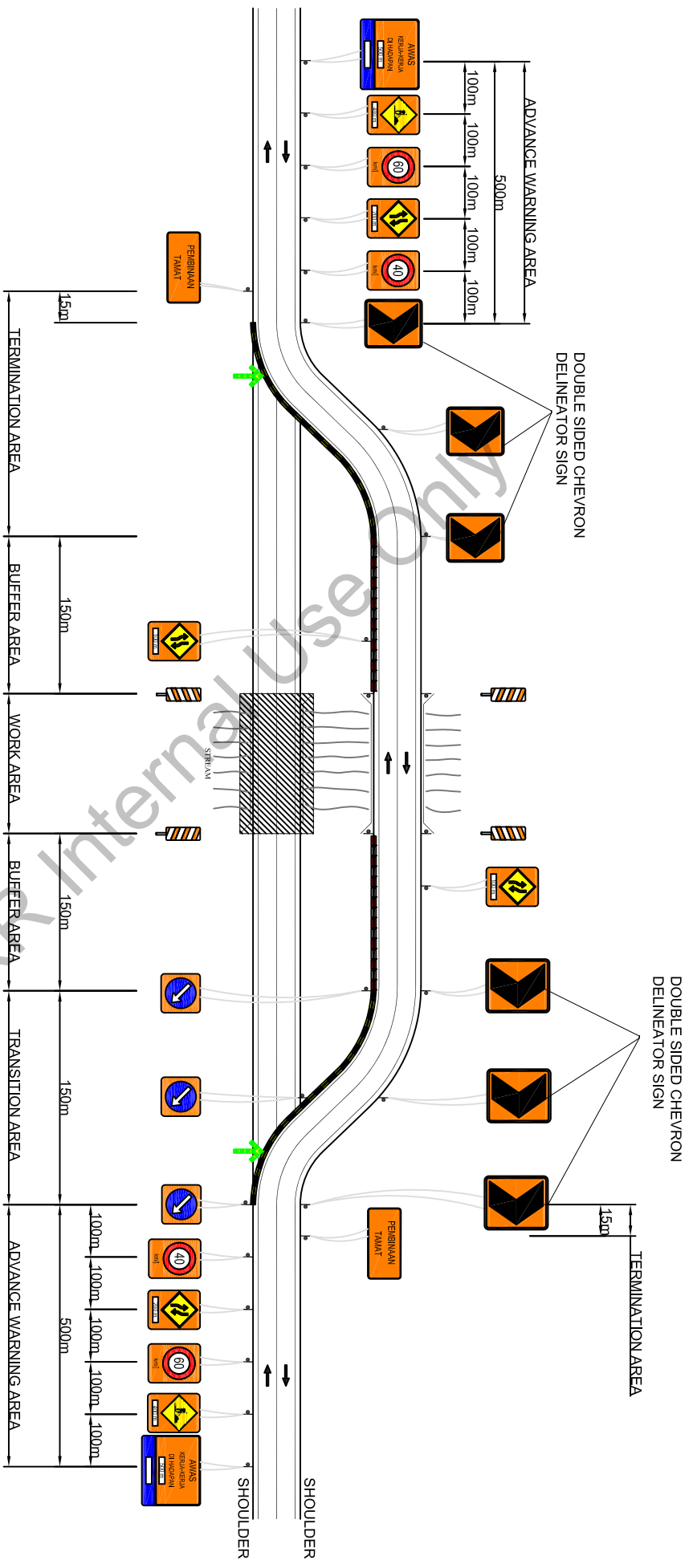

**LEGEND**

	TRAFFIC FLOW
	FLASHING ARROW
	PLASTIC BARRIER
	CONCRETE BARRIER
	WORK AREA
	EXCAVATION AREA WITH DEPTH 1m OR MORE

- NOTES**
1. BARRIERS SHALL BE CONTINUOUS ALONG THE WORK AREA.
  2. PLASTIC HOARDING SHALL BE INSTALLED IF THERE ARE ANY HEAVY MACHINERIES OR ACTIVITIES WITHIN THE CONSTRUCTION AREA.
  3. FLASHING LIGHT (BLINKERS) SHALL BE INSTALLED EVERY 30m ON AT STRAIGHT AND 10m ON AT TAPER OR CURVE.
  4. FOR NIGHT WORKS, THE CONTRACTOR SHALL INSTALL A RELIABLE FLOOD LIGHT SYSTEM (ANTI-GLARE FEATURE).
  5. PROVIDE A SAFE ENTRANCE AND EXIT FOR CONSTRUCTION VEHICLES WHICH SHALL BE MANNED BY FLAGMAN.

SPEED LIMIT (km/h)	1ST REDUCTION SPEED (kph)	2ND REDUCTION SPEED (kph)
80	70	50
70	60	40
60	50	30
50	40	30



Scale : Not to scale

FIGURE 612: LONG TERM WORKS ON BRIDGE OF SINGLE CARRIAGEWAY (RURAL HIGH SPEED)

## **7.0 TAKING OFF QUANTITIES**

### **7.1 Objective**

The objective of this chapter is to provide a guideline and also examples on taking off quantities for the items specified in the standard BQ for Traffic Management during construction. The estimation procedures will be a basis for the engineers coordinating the design process to estimate the costs of the Traffic Management so that adequate funds can be allocated to provide for proper traffic management during construction.

### **7.2 Practices In Estimating BQ For Traffic Management**

Due to the many problems faced and the poor quality provided by the contractors on Traffic Management through the previous procedure, the Traffic Management Costs has been taken out from the Preliminaries Bill and now exists as a separate bill on its own. All the quantities for the items specified in the Bill will be Provisional Quantities except for the Traffic Management Plan and Safety Report that will be priced as Lump Sum. Through this procedure, the detailed items, materials and quantities to be provided on site are specified in the bill.

### **7.3 Taking Off Quantities**

For the estimation of the quantities for Traffic Control Devices (TCD) used in Traffic Management during construction, the overall Traffic Control Plan (TCP) during Design Phase can be used as a basis for the type of Traffic Control Devices (TCDs) and Temporary Signs to be installed.

The estimations **7.3.1** to **7.3.3** are based on assumptions made for each case study.

### 7.3.1 Example of Case Study 1: Short/Long Term Works Where Traffic Is Detour (Rural Low Speed) (Refer Figure 6.10)

#### 7.3.1.1 Assumptions:-

- (a) There is no street lighting in the contract area.
- (b) 2 km length of construction areas.
- (c) The construction area shall be segregated from the traffic way from commencement of work to completion time to prevent uncontrolled disruption to the traffic movements. Continuous interlocking barriers shall be used to segregate the working areas from the traffic way.
- (d) The excavation area with 1m deep or more (work area) shall be carried out at not more than 200m length at one time at 2 location along the 2 km.
- (e) There will be 1 traffic diversion at every 2 km. The length of temporary traffic diversion is assumed to be 30m (to be checked) length.
- (f) The traffic diversion costs exclude the earthworks and pavement costs. It comprises cost only for TCD and temporary road markings.
- (g) For estimation purposes, the temporary signs and Traffic Control Devices (TCD) quantities are based on per work area applications. For example, if the total work area are 2 locations, the quantities to be installed is multiplied by 2.
- (h) The quantities do not take into consideration the percentage of losses and damages.

#### 7.3.1.2 Estimation on BQ Items

##### (a) Concrete Barrier

Transition Area	= 100m + 100m = 200m
Excavation Area with 1m deep or more	= 200m × 2 location = 400m
Total	= 200m + 400m = 600m
Length of Concrete Barrier	= 1m
So, number of Concrete Barrier	= 600m ÷ 1m = <b><u>600 nos.</u></b>

(b) **Plastic Barrier**

Buffer Area	= 110m + 110m = 220m
Work Area less than 1m deep	= 2000m – 400m = 1600m
Total	= 220m + 1600m = 1820m
Length of Plastic Barrier	= 1m
So, number of Concrete Barrier	= 1820m ÷ 1m = <b><u>1820 nos.</u></b>

(c) **Plastic Hoarding**

Plastic Hoarding on barriers shall be placed at work area where the view of activities is to be blocked.

Total length of work area	= 200m + 200m = 400m
Length of Plastic Hoarding	= 1m
So, number of Plastic Hoarding	= 400m ÷ 1m = <b><u>400 nos.</u></b>

(d) **Delineator String**

Transition Area	= 100m + 115m = 215m
Buffer Area	= 110m + 110m = 220m
Work Area	= 2000m

Total area for Delineator String installation  
= 215m + 220m + 2000m  
= **2435m**

1 roll of Delineator String = 50m

Number of Delineator String = 2435m ÷ 50m  
= **49 rolls**

(e) **Flashing Light (Blinkers)**

- (i) At Transition & Termination Area  
= 100m + 115m  
= 215m

Spacing of devices = 10m c/c (Refer Table 5.3)

So, number of Flashing Light (Blinkers)  
= 215m ÷ 10m  
= 22 nos.

- (ii) At Work Area = 2000m  
At Buffer Area = 110m + 110m  
= 220m

Total at straight stretch = 2000m + 220m  
= 2220m

Spacing of devices = 30m c/c (Refer Table 5.3)

So, number of Flashing Light (Blinkers)  
= 2220m ÷ 30m  
= 74 nos.

Total number of Flashing Light (Blinkers)

= 22 nos. + 74 nos.  
= **94 nos.**

(f) **Beacon Light**

To be placed at the start of a specific work area. The number of beacon lights needed.:-

At the specific work site = 1 nos. x 2 way = **2 nos.**

(g) **Flashing Arrow**

To be placed at Transition Area in Work Zone.  
The number of Flashing Arrow = 2 nos.

(h) **Temporary Signs**

Size of temporary signs involved:

T.1(Advance Warning Sign)	= 1.524m × 1.829m = 2.79m <sup>2</sup>
T.2(Road Works Sign)	= 1.219m × 0.914m = 1.11m <sup>2</sup>
T.3(Speed Limit Sign)	= 1.219m × 0.914m = 1.11m <sup>2</sup>
T.6(Detour Sign)	= 1.219m × 0.914m = 1.11m <sup>2</sup>
T.7(Keep Left/Right Sign)	= 0.914m × 0.750m = 0.69 m <sup>2</sup>
T.1(Road Works Sign (Work Area))	= 0.914m × 0.914m = 0.84 m <sup>2</sup>
T.11a(Chevron)	= 0.900m × 0.750m = 0.68m
T.11b(Chevron)	= 0.900m × 0.750m = 0.68m
T.18e(Warning Sign)	= 0.800m × 1.200m = 0.96 m <sup>2</sup>

ITEM	UNIT	QUANTITY
a) Not exceeding 1m <sup>2</sup>		
i) T.7(Keep Left/Right Sign)	nos.	6
ii) T.17 (Road Works Sign (Work Area))	nos.	5
ii) T.18e (Warning Sign)	nos.	2
iii) T.11a(Chevron)	Nos.	3
iv) T.11a(Chevron)	Nos.	3
b) 1-2 m <sup>2</sup>		
i) T.2 (Road Works Sign)	nos.	2
ii) T.3 (Speed Limit Sign)	nos.	9
iii) T.6 (Detour Sign)	nos.	4
c) 2-3 m <sup>2</sup>		
i) T.1(Advance Warning Sign)	nos.	2

(i) **Road Markings**

(i) Wide continuous line  
= (15m + 100m + 110m + 2000m + 110m +  
100m + 15m) × 2 side  
= **4900m**

(i) Wide intermittent line  
= 15m + 100m + 110m + 2000m + 110m + 100m  
+ 15m  
= **2450m**



**(b) Flashing Light (Blinkers)**

- (i) At Transition Area = 100m + 100m  
= 200m

Spacing of devices = 10m c/c (Refer Table 5.3)

So, number of Flashing Light (Blinkers)  
= 200m ÷ 10m = 20 nos.

- (ii) At straight stretch = 50m + 100m  
= 150m

Spacing of devices = 30m c/c (Refer Table 5.3)

So, number of Flashing Light (Blinkers)  
= 150m ÷ 30m  
= 5 nos.

Total number of Flashing Light (Blinkers)  
= 20 nos. + 5 nos.  
= **25 nos.**

**(c) Flashing Arrow**

To be placed at Transition Area in Work Zone.  
The number of Flashing Arrow = 1 nos.

**(d) Temporary Signs**

Size of temporary signs involved:

- T.1(Advance Warning Sign) = 1.524m × 1.829m = 2.79m<sup>2</sup>  
T.2(Road Works Sign) = 1.219m × 0.914m = 1.11m<sup>2</sup>  
T.3(Speed Limit Sign) = 1.219m × 0.914m = 1.11m<sup>2</sup>  
T.6(Detour Sign) = 1.219m × 0.914m = 1.11m<sup>2</sup>  
T.7(Keep Left/Right Sign) = 0.914m × 0.750m = 0.69 m<sup>2</sup>  
T.18e(Warning Sign) = 0.800m × 1.200m = 0.96 m<sup>2</sup>

ITEM	UNIT	QUANTITY
a) Not exceeding 1m <sup>2</sup>		
i) T.7(Keep Left/Right Sign)	nos.	4
ii) T.18e (Warning Sign)	nos.	3
b) 1-2 m <sup>2</sup>		
i) T.2 (Road Works Sign)	nos.	3
ii) T.3 (Speed Limit Sign)	nos.	6
iii) T.5 (Road Narrow Sign)	nos.	3
c) 2-3 m <sup>2</sup>		
i) T.1(Advance Warning Sign)	nos.	3

### 7.3.3 Example of Case Study 3: Short/Long Term Works Where Traffic Is Detour on Bridge (Rural High Speed) (Refer Figure 6.12)

#### 7.3.3.1 Assumptions:-

- (a) There is no street lighting in the contract area.
- (b) Work area is 100m length.
- (c) Assume 10m lateral shift with ratio of 1:20.
- (d) The construction area shall be segregated from the traffic way from commencement of work to completion time to prevent uncontrolled disruption to the traffic movements. Continuous interlocking barriers shall be used to segregate the working areas from the traffic way.
- (e) The traffic diversion costs exclude the earthworks and pavement costs. It comprises cost only for Traffic Control Devices (TCD) and temporary road markings.
- (f) The quantities do not take into consideration the percentage of losses and damages.

#### 7.3.3.2 Estimation on BQ items

##### (a) Concrete Barrier

To be used where excavation on the road side is 1m deep or more (Refer to Application Requirement in Part Two : Temporary Traffic Control Devices).

Transition & Termination Area = 200m + 200m  
= 400m

Buffer Area = 150m + 150m  
= 300m

Total length = (400m + 300m)  
× 2 side  
= 1400m

Length of Concrete Barrier = 1m

So, number of Concrete Barrier = 1400m ÷ 1m  
= **1400 nos.**

##### (b) Delineator String

Total length for Delineator String installation  
= (200m + 150m + 150m + 200m) × 2 side  
= 1400m

1 roll of Delineator String = 50m

Number of Delineator String = 1400m ÷ 50m  
= 28 rolls

**(c) Flashing Light (Blinkers)**

- (i) At Transition & Termination Area  
= (200m + 200m) × 2 side  
= 800m

Spacing of devices = 10m c/c (Refer Table 5.3)

So, number of Flashing Light (Blinkers)  
= 800m ÷ 10m = 80 nos.

- (ii) At straight stretch = (150m + 150m) × 2 side  
= 600m

Spacing of devices = 30m c/c (Refer Table 5.3)

So, number of Flashing Light (Blinkers)  
= 600m ÷ 30m = 20 nos.

Total number of Flashing Light (Blinkers)  
= 80 nos. + 20 nos.  
= **100 nos.**

**(d) Beacon Light**

To be placed at the start of a specific work area. The number of beacon lights needed:-

At the specific work site = 1 nos. x 2 way = 2 nos.

**(e) Flashing Arrow**

To be placed at Transition Area in Work Zone.  
The number of Flashing Arrow = 2 nos.

**(f) Temporary Signs**

Size of temporary signs involved:

T.1(Advance Warning Sign)	= 1.524m × 1.829m = 2.79m <sup>2</sup>
T.2(Road Works Sign)	= 1.219m × 0.914m = 1.11m <sup>2</sup>
T.3(Speed Limit Sign)	= 1.219m × 0.914m = 1.11m <sup>2</sup>
T.6(Detour Sign)	= 1.219m × 0.914m = 1.11m <sup>2</sup>
T.7(Keep Left/Right Sign)	= 0.914m × 0.750m = 0.69 m <sup>2</sup>
T.11a(Chevron)	= 0.900m x 0.750m = 0.68m
T.11b(Chevron)	= 0.900m x 0.750m = 0.68m
T.12(Vertical Panel Sign)	= 0.900m × 0.300m = 0.27m <sup>2</sup>
T.18e(Warning Sign)	= 0.800m × 1.200m = 0.96 m <sup>2</sup>

ITEM	UNIT	QUANTITY
a) Not exceeding 1m <sup>2</sup>		
i) T.7(Keep Left/Right Sign)	nos.	3
ii) T.12 (Vertical Panel Sign)	nos.	4
ii) T.18e (Warning Sign)	nos.	2
iii) T.11a(Chevron)	Nos.	6
iv) T.11a(Chevron)	Nos.	6
b) 1-2 m <sup>2</sup>		
i) T.2 (Road Works Sign)	nos.	2
ii) T.3 (Speed Limit Sign)	nos.	4
iii) T.6 (Detour Sign)	nos.	4
c) 2-3 m <sup>2</sup>		
i) T.1(Advance Warning Sign)	nos.	2

**(g) Road Markings**

(i) Wide continuous line  
= (30m + 200m + 150m + 30m + 150m + 200m + 30m) × 2 side  
= **1580m**

(ii) Wide intermittent line  
= 30m + 200m + 150m + 30m + 150m + 200m + 30m  
= **790m**

## 8.0 PLACEMENT AND REMOVAL OF TRAFFIC CONTROL DEVICES

This Chapter discusses the important aspects of the process of placing and removal of traffic control devices in work zones including its preparation, the order of device placement, the treatment of existing signs, and the use of “shadow” or protection vehicles.

### 8.1 Preparation for Placement Process

The placement, modification, and removal of traffic control devices for road construction and maintenance operations can be enhanced by adequate preparations. This is particularly important because of the hazard associated with these activities. The installation and removal of work zone traffic control devices create situations that are often far more hazardous than the operation when the traffic control devices are already installed. These hazards are often greater than those during the work activity because:

- (a) Workers placing advanced warning and channelizing devices must be in the roadway at points of high conflict without the full protection of the devices being placed.
- (b) The placement operation constitutes an unexpected situation for the motorists as they are confronted with a roadway partially closed and with partial traffic control devices.

The inherent danger of these operations can be lessened by using techniques that emphasize safety. Also, to reduce exposure to such hazards, the installation should be done as quickly as possible. To this end, several elements must be considered before the setting up of the traffic control zone.

#### 8.1.2 Coordination with Affected Groups

Advance time coordination should be done with all affected organizations and groups (but not limited to) such as:

- (a) Police
- (b) Traffic Department of affected Local Council
- (c) Emergency services such as the fire dept, hospitals, etc.
- (d) Media platform (news, social, etc.)
- (e) Businesses and industries
- (f) Public transportation,
- (g) Residents and Residents' Representatives

Coordination prior to the placement of the traffic controls at a site greatly improves the safety and efficiency of the installation. The coordination includes the following (but not limited to) considerations:

- (a) Advance publicity
- (b) Selection of the day and time-of-day for the setting up
- (c) Analysis of traffic volumes
- (d) Selection of crew work hours
- (e) Consideration of emergency requirements in case of utility breakdown, road accidents, etc.

#### 8.1.3 Inventory and Storage

All traffic control devices required for the placement and maintenance of the zone should be on-hand and in good condition. Also, special equipment, trailers, and trucks should all be operating properly and safely.

Devices maintained in inventory need to be formally organized to assure that all items are actually in stock and can be rapidly retrieved. Traffic control devices need to be stored properly to avoid marring, and all devices need to be kept clean.

All mechanical and electrical elements and equipment require routine maintenance to assure that they will function properly. Devices should be inspected carefully when they are returned to inventory. All devices found to be non-standard or in poor condition should be replaced, modified, or repaired. Equipment for the roadway work zone must be in good operating condition, otherwise there will be occurrences of breakdowns, delays, and increased site occupancy time.

Good practice suggests that devices be marked to identify ownership. The name and phone number of the owner may be shown on the non-reflective surface of the barricades. This procedure pinpoints responsibility and minimizes "borrowing." Standard inventory packages of organized traffic control devices can be established for activities by pre-packaging and ensuring checklists for each activity and location.

#### **8.1.4 Training and Instruction**

All Traffic Management Personnel should be trained for their tasks, with particular emphasis on safety. In addition, to ensure that all Traffic Management Personnel know their installation assignments, and to assure an efficient and speedy operation, the supervisor should review the installation process with his crew before going into the field. If either a new or different procedure is to be used, or if new people are in the team, these instructions are essential. In some cases, a rehearsal on an abandoned segment of roadway may be desirable.

### **8.2 Placement**

#### **8.2.1 Placement Sequence**

Devices are installed in the direction that traffic moves that is, moving "downstream". The first device placed is the first advance warning sign. The installation then proceeds with the:-

- (a) Advance warning area
- (b) Transition area
- (c) Buffer area
- (d) Work area
- (e) Termination area

If traffic in both directions will be affected, such as with work in the centre lanes, the devices can be placed in both directions at the same time, starting at each end farthest from the work area. Alternately one direction can be installed before the other.

When one direction of traffic will be directed into opposing traffic lanes, the signs, devices, and pavement markings for the opposing traffic should be placed first. It is essential to channelize opposing traffic out of its lane before moving the oncoming traffic into the lane.

When all signs and devices are placed for opposing traffic, the devices for the oncoming direction can then be set up.

When signs or channelizing devices are to be installed and removed several times during the work operation, a spot should be painted where each device is located. This way the installation can be repeated quickly and properly. The devices should either be stored off the roadway, out of sight, or transported to another location. Channelizing devices should not be stored on the shoulder of the roadway, as this would appear to be a shoulder closure.

High-level warning devices, flagmen, or flashing vehicle lights should be used to warn the road users of the presence of workers. Flashing arrow panels are valuable to assist the workers during placement or removal of channelizing devices for lane closures.

### **8.2.2 Placement Procedure**

Work vehicles should park in a safe location to unload teams and devices. Locations such as these should be the priority;

- (a) At kerbs
- (b) On shoulder
- (c) On side street

The work vehicle may serve as the advance warning device by using its flashing/rotating lights while the first warning signs are being placed. To protect the teams, the device truck should be located upstream of the teams. This can be awkward, however, if the signs are unloaded from the rear of the truck.

On high-speed roads, a “backup,” “shadow,” or “protection,” vehicle should be used. This vehicle should first be positioned on the shoulder some 30 meters or more behind the device truck when the first signs are placed. The shadow vehicle uses special lights or a flashing arrow panel to warn traffic. When the team needs to work on the roadway, the shadow vehicle is moved into the travelled lane. Truck mounted attenuators are desirable for these vehicles.

### **8.2.3 Placing Channelizing Devices**

When closing a lane, tapers are laid out in a straight line starting at the shoulder. Each channelizing device is then placed in sequence moving downstream. When placed by hand, the devices should be moved out from the shoulder with the worker looking towards traffic as he moves into the lane to place the device. When channelizing tapers are installed, each device is placed 30cm further into the lane that is being closed.

### **8.2.4 Lateral Position**

For some closures, traffic doesn't have to be excluded from the entire width of the lane to establish a safe workspace. Under these circumstances, the work area channelizing devices should be placed a few meters back from the lane line as to:

- (a) Reduce the chances of the devices being hit
- (b) Provide increased lateral clearance, thereby increasing capacity

#### **8.2.5 Cone Placement**

Cones may be placed either by workers on foot or from a moving vehicle. When working from a vehicle, the truck should be equipped with a suitable worker platform and railing. On high-speed roadways, a shadow vehicle should be used to protect the team which is working from the back of the truck.

#### **8.2.6 Expressway Lane Closures**

Expressway lane closures should be more carefully carried out and are categorised into two types. "Exterior" lanes are those with a shoulder along one edge. "Interior" lanes, such as the centre lane of a three lane roadway, are bordered by lanes on both sides.

#### **8.2.7 Exterior Lane Closures**

The protection vehicle travels along the shoulder or exterior lane if no shoulder is available. It is equipped with a warning light and a flashing arrow panel. The protection vehicle then stops in a blocking position at least 30m upstream while the first warning sign is located. This operation is repeated for all warning signs -- first for one side, then the other side of the roadway.

When all signs are in place, channelization devices are then placed. The protection vehicle gradually encroaches upon the exterior lane as the workers install the taper in front of the protection vehicle. Finally, the protection vehicle is positioned in the closed lane while the work area channelization is installed.

#### **8.2.8 Interior or Center Lane Closures**

When work is necessary on an interior or center lane, the recommended procedure is to also close the adjacent exterior lane to avoid an "island" closure. In locations where, due to traffic volume or road geometrics it must be carried around both sides of an interior lane work space, the preferred procedure is to first close an exterior lane upstream from the work space, particularly for high-speed conditions. Next, the interior lane traffic is channelized into the previously closed exterior lane.

Warning signs are placed on both sides of the approach warning area. The exterior lane is then closed as described above to create an "empty" work space.

To continue the setup, the protection vehicle moves carefully into the closed exterior lane and workers complete the exterior lane channelization and closing taper. The shadow vehicle then moves to the downstream end of the closed exterior lane and blocks the

adjacent center lane. The taper which moves traffic from the interior lane to the previously closed exterior lane is placed, and work area channelization is established on both sides of the closed center lane.

In the final configuration, the shadow vehicle can be moved into the work area behind the taper. Traffic may now flow around either side of the work area.

### **8.3 Modification and Removal**

Where possible, traffic control area should be removed by picking up the devices in a reverse sequence to that used for installation. This requires moving backwards or upstream through the zone.

With no shoulders, the removal of advance warning signs is made in the downstream direction.

Where extensive modifications to the traffic control area are required, as when switching a closure from one side of the roadway to the other, it may be necessary to remove the entire zone and then re-install it in the new configuration.

Portable concrete barriers require special care and planning to place and remove. Normally the lane next to the barrier must be closed while the barriers are placed or moved. This operation should be scheduled to cause as little disruption as possible.

### **8.4 Special Equipment and Techniques**

Some Maintenance Agencies may have special equipment to facilitate and expedite the placement process, such as, trucks with racks in which signs are loaded in the reverse sequence to that needed; that is, the last sign put on is the first one to be taken off.

Special traffic control vehicles should be available for placement, maintenance and removal of traffic control zone devices and signs.

These vehicles should be employed to:

- (a) Carry devices to worksites.
- (b) Facilitate handling.
- (c) Help to organize and protect signs and devices.
- (d) Cater for emergency situations.

Special features of these traffic control vehicles may include;

- (a) Appropriate colour (orange)
- (b) Flashing/rotating lights or beacons
- (c) Flashing arrow panels
- (d) Sign racks
- (e) Cone chutes
- (f) Power lift tailgates
- (g) Worker platform and protective railing
- (h) Variable Message Signs
- (i) Crash cushions on shadow vehicles

## 9.0 MAINTENANCE OF TRAFFIC CONTROL ZONES

Traffic control zones should be maintained so that they remain as effective as when first installed. Documentation of maintenance and inspections is necessary in the event of lawsuits resulting from accidents or other grievances suffered by an injured party. This Chapter will explain the types of inspections and maintenance required and methods to document inspections and actions taken.

### 9.1 Inspection and Maintenance Program

Once the traffic control zone is established, it is important that it continues to function effectively. The traffic control devices must be maintained as it was installed or modified to ensure the motorists are not misled with unnecessary changes to the work zone shapes and sizes.

Maintenance is needed to service the traffic control devices and make corrections required by any combination of the following factors:

- (a) Traffic accidents
- (b) Device displacement by;
  - (i) vehicular contact
  - (ii) slip stream from trucks
  - (iii) workers
  - (iv) wind
- (c) Damage caused by construction activities
- (d) Weather damage
- (e) Malfunctions and burn outs
- (f) Physical deterioration
- (g) Dust, dirt, grime and bitumen over spray.
  - (i) on sign faces
  - (ii) on barriers or cones
  - (iii) on reflectorized rails or string delineators
- (h) Dirt and debris on roadway.
- (i) Vandalism and theft.

#### 9.1.1 Elements of an Inspection Program

A comprehensive inspection and maintenance program should include the following elements.

- (a) A formalized plan
- (b) Defined inspection procedures
- (c) A form to record the findings of the field inspection
- (d) A repair program
- (e) An adequate inventory of devices for emergency replacements or repairs
- (f) Day and night review of the marking and traffic control devices along the travel path through the work zones
- (g) Procedures to assure that specified repairs are made
- (h) Formal documentation of inspections and repairs
- (i) Identification of possible causes of accidents and skid marks

The inspector will need to make decisions during the inspection. He must exercise judgement in establishing appropriate practices. As deficiencies are observed, the following choices are available:

- (a) Make on-the-spot corrections
- (b) Call for emergency repairs (radio or phone)
- (c) Instruct the work crew to make routine repairs during the next work day
- (d) Schedule deferrable corrective actions, such as sign cleaning

A key element of the program is the procedure that ensures that the required maintenance is performed. Corrective action should be fully documented with date, time and action taken.

## **9.2 Inspection Procedures**

### **9.2.1 Responsibility**

On construction projects, the contractor should designate a Traffic Management Officer (TMO) who should be responsible for traffic control design, installation, maintenance and routine inspections.

Less frequent but additional periodic inspections should be performed by senior staff of the contractor (typically his superintendent), the Superintending Engineer and the Road Authority (the resident engineer and/or the traffic engineer).

Lines of communication and responsibility must be clearly established between the person conducting routine inspections and senior contractor or agency personnel. This communication is especially important between those in control of routine maintenance activities and those with greater authority. Effective communication ensures that urgent problems can be brought promptly to the attention of officials who can respond immediately.

### **9.2.2 Frequency**

Factors must be considered.

- (a) Project size and duration

To determine the frequency of inspections, the following Degree of liability

- (a) Severity of hazards
- (b) Frequency at which damage occurs
- (c) Number of deficiencies observed during previous inspections.
- (d) Traffic volumes and speed.

Traffic controls left in place overnight should be inspected during hours of darkness at the same frequency as during the daylight hours. Inspections should also be carried out during adverse weather conditions to ensure safety requirements are met and adequate road drainage is maintained during the construction period.

### 9.2.3 Documentation

Documentation is an essential part of the traffic control maintenance function. It is necessary for good planning and for project accounting.

Documentation serves to:

- (a) Ensure the integrity of the project traffic control; and
- (b) Provide a means of
  - (i) identifying the maintenance needed
  - (ii) providing a tool for getting maintenance started
  - (iii) checking to see that maintenance is done
  - (iv) documenting that maintenance was done

Well maintained traffic control maintenance records provide substantial support for the project in the following ways.

- (a) The records aid in the evaluation of the effectiveness of the planned and modified traffic control installation.
- (b) Traffic control maintenance records provide evidence of a proper traffic control installation in the event of a lawsuit arising from an accident at the worksite.

### 9.2.4 Record Keeping

Record keeping begins with an inventory of traffic control devices located in both the shop and field. With this information, future material needs can be estimated based on planned projects and anticipated damages and thefts. Costs can be budgeted, and needed material can be purchased (or fabricated) prior to beginning work.

Good record keeping procedures suggest that the time and location of the installation and removal of traffic control devices be noted. Although this record keeping can be time consuming for a moving maintenance operation, significant traffic control actions taken by the field crew should be recorded. These records should include:

- (a) Starting and ending time of work
- (b) Location of work,
- (c) Names of personnel,
- (d) Types of equipment used, and
- (e) Any *changes* in temporary or permanent regulatory devices

Major projects will require more detailed record keeping since they may involve greater amounts of funds from the contract BQ, and longer distances and time of physical exposure with resulting potential danger to the worksite employees and the motorists. Several methods of recording traffic controls are available. These include:

- (a) Photographs either keyed to a diary or containing a brief description of
  - (i) Date
  - (ii) Time
  - (iii) Location with GPS co-ordinates if possible.
  - (iv) Direction, and
  - (v) Photographer's name.

- (b) Videotaping of work zone drive-through can also be used to document the placement and condition of traffic control devices.
- (c) Special notes on construction plans (preferably the traffic control plan sheet); and
- (d) Diary entries of times, location and names of individuals (when known) involved in the;
  - (i) installation,
  - (ii) change, and
  - (iii) removal of traffic control devices.

Work orders also serve as a reference, and should be keyed to the diary when used. When the maintenance inspection process reveals a condition that requires correction, the documentation should include:

- (a) Description of the correction needed, when it was noted, and by whom;
- (b) Corrections made or deferred and why;
- (c) Replacements made or deferred and why; and
- (d) Any other actions needed.

Each agency should have general checklist for different types of operations and conditions. These can be modified to meet the requirements of an individual worksite. Inspection sheets should be developed for major projects from the general checklists and schedule guidelines. For typical worksites, standard inspection sheets can be prepared and used. An example for the inspection checklist may be referred in **Appendix A**.

### 9.3 Training and Equipment Needs

#### 9.3.1 Training

Several elements should be considered in preparing for and performing traffic control zone inspections and maintenance. Personnel designated to perform these tasks must understand the general traffic control process, have a deep appreciation for safety, and be trained in device maintenance procedures. Training should include:

- (a) Proper cleaning methods for the various types of equipment and reflective materials.
- (b) Maintenance techniques for mechanical and electrical equipment,
- (c) Proper placement and ballasting of traffic control devices
- (d) Methods to check sign reflectivity,
- (e) Knowledge of the hazard potential of various types of situations
- (f) Solutions that may be used to solve various problems.
- (g) Situations requiring special technical assistance (such as hazardous materials), and procedure to be followed in securing such assistance, and
- (h) Documentation techniques.

### 9.3.2 Personnel, Equipment and Materials

Sufficient equipment and materials should be readily available to perform the required tasks. Usually, a dedicated vehicle will be needed to keep all the required material on-hand. The following items may be needed :

- (a) Communications equipment
  - (i) Two-way radio
  
- (b) Safety equipment for personnel safety and emergency situations
  - (i) flashing warning lights or beacons
  - (ii) spot/flood lights
  - (iii) flares
  - (iv) first aid kit
  - (v) safety helmet
  - (vi) high visibility / reflective vests
  
- (c) Tools and hardware for on the spot repairs
  - (i) hammers
  - (ii) screwdrivers
  - (iii) pliers and wrenches (crescent)
  - (iv) wrecking bar
  - (v) shovel
  - (vi) saw
  - (vii) nails, nuts, bolts and washers
  - (viii) tape measure
  - (ix) knife
  
- (d) Spare parts and materials
  - (i) batteries
  - (ii) bulbs
  - (iii) fuel
  - (iv) sandbags
  - (v) posts
  - (vi) hardware
  - (vii) wire and rope
  - (viii) pavement marking tape
  - (ix) reflective tape
  - (x) washing materials
  
- (e) Spare devices
  - (i) plastic barriers
  - (ii) cones
  - (iii) temporary signs (A-shape)
  - (iv) flashing light (blinkers)
  
- (f) Reference materials
  - (i) Traffic Control Plan
  - (ii) inspection forms and checklist
  - (iii) logbook
  - (iv) pencils
  - (v) accident guidelines and report forms
  - (vi) emergency procedures and telephone number

## 10.0 REPORTS

To ensure proper adherence to the standards and specifications and also to ensure adequate implementation, there must be constant reporting and checking carried out at the work zones.

Based on the scope of activities required, the documents and reporting requirements are as follows:

- (a) The Traffic Management Plan (TMP)
- (b) Traffic Management Safety Report (TMSR)

### 10.1 The Traffic Management Plan

The Traffic Management Plan is a document to be prepared by the Contractor's Engineer. The document should spell out the Contractor's proposal on how he wants to manage the traffic on site during the course of construction. The report must be verified by a Profession Engineer.

The format of the Proposal should include the following items:

**(a) Project Information**

This section should include:

- (i) Introduction of project
- (ii) Summary of project
- (iii) Location plan

**(b) Detailed Construction Work Programme**

**(c) Method Statement of Traffic Management by Construction Sequences**

The construction sequences and method statements are outlined in this section. The proposed Traffic Management designs are shown here.

**(d) Public Notification**

In this section, the Contractor should list down the media he intends to use to notify the public about the project.

**(e) Existing Facilities**

The Contractor must carry out a detailed survey of the existing facilities along the project route. This is to be presented in this proposal based on the chainages and the use of photos.

**(f) Traffic Control Plan**

The TCPs designed by the Contractor should be shown here. It should consists of the placement and type of traffic control devices to be used in all work zones involved in the project as well as details about the type of work zones to be implemented in each phase of the work. The following are to be produced:

- (i) Scaled drawings of the control zones
- (ii) A list of devices selected for installation
- (iii) Identification of special manpower needs such as flagmen
- (iv) Scaled drawings of construction stages, including detours, lane closure, U-turns
- (v) Placement and Removal dates

- (vi) Identification of special needs such as night time delineation, temporary signals, pedestrian crossing facilities, contra flow along dual carriageways

**(g) Additional Details**

Additional details required are as follows:

- (i) Organization Chart
- (ii) Emergency Response Plan (ERP)
- (iii) Detailed Temporary Warning Signs

## **10.2 Traffic Management Safety Reports (TMSR)**

The Traffic Management Safety Reports (TMSR) is an essential document in the execution of the project. These reports are to be submitted at 3 monthly intervals to the S.O., the Supervision Engineers and the Road Safety Auditor. These reports are to be prepared by the Traffic Management Officer (TMO) and shall include the following:

- (a) TCPs prepared and enforced on the ground
- (b) TCPs for the next three months' work
- (c) Estimated duration of each TCP (Placement dates and expected Removal dates) are required.
- (d) Accident occurrences and its analysis.
- (e) Performance Indicators

A suggested format for the TMSR is as shown below:

**(a) Introduction**

- (i) Objective of the TMSR report
- (ii) Objective of the Traffic Management Plans
- (iii) Photos of the site
- (iv) Schedule of the TMSR reports for the project

**(b) Background of Project**

- (i) Project details
- (ii) Traffic data
- (iii) Strip map
- (iv) Construction Program
- (v) The importance of the road
- (vi) The conditions of the road and surrounding area

**(c) Project Contractor's Site Organisation**

- (i) Organization chart of the project
- (ii) TMT and ERT organization
- (iii) List the tasks and responsibilities of each member of the TMT and ERT

**(d) Work Progress and Traffic Control Plan**

- (i) Construction Progress and TCPs for the last 3 months
  - Give details of the work done and the TCPs
  - Records of workers, traffic control devices and inventories used
- (ii) Construction Schedule and TCPs for the next 3 months
  - Give details of the work to be carried out and the TCPs proposed
  - Records of workers, traffic control devices and inventories to be used
- (iii) Photos of site where TCPs are to be applied

**(e) Photos during the operation of the Traffic Control Plans**

Provide photos of the TMWZ for the last 3 months

**(f) Methods of Assessing Performance of TCPs**

The Contractor should propose suitable methods of assessment

- Acceptable methods are; Degree of Congestion, Queue Length, Travel Time, Number of Accidents, Number of Complaints, and other quantifiable items
- “Before” and “After” data should be collected

**(g) Emergency Response Plan (ERP) and Emergency Response Team (ERT)**

(i) Emergency Response Plan (ERP)

- Give details of the plan and show “alternative route”

(ii) Emergency Response Team (ERT)

- Give details of the Organization Chart and “Line of Communication”

**(h) Records of Public Complaints**

Provide records of public complaints through media, letters, newspapers, etc

**(i) Damage to Vehicles**

Provide records and photos of vehicles experiencing problems within the Work Zones

**(j) Accident Analyses**

(i) Provide records of accidents within Work Zones during the last 3 months

- Give detail of dates, time, collision diagram, location and damages and TCP used. Show photos.

(ii) Provide records of accidents within the Project Work Zones from the start of project.

- Give details of dates, time, collision diagram, location and damages and TCP used. Show photos.

(iii) Provide accidents summary and trend.

**(k) Evaluation**

(i) Evaluate the effectiveness of the TCPs during the last 3 months

(ii) Highlight main issues for the next 3 months

(iii) Propose steps to upgrade the situations

(iv) Alert JKR on the issues which are sensitive and propose mitigations

**(l) Recommendations**

(i) Provide recommendations for actions to reduce accidents and public complaints.

(ii) Provide recommendations on how to improve the conditions at site.

For JKR Internal Use Only

**PART TWO**  
**TEMPORARY TRAFFIC**  
**CONTROL DEVICES**

For JKR Internal Use Only

## **PART TWO: TEMPORARY TRAFFIC CONTROL DEVICES**

### **1.0 GENERAL**

Traffic control devices are markers, signages, channelizing and signal devices. They are used to inform, warn, guide, or regulate traffic movement and control vehicle speeds. Traffic control devices also provide important information to users about detours and traffic delays.

### **2.0 CATEGORY OF TRAFFIC CONTROL DEVICES**

Traffic control devices are categorized based on their functions such as guidance, warning signs and channelization. They are Temporary Signage, Temporary Road Marking and Temporary Management Equipment consisting of items as follows:-

#### **2.1 Temporary Signage**

Temporary signage shall be rectangular shaped traffic signs with fluorescent orange background and the type of signs shall be in accordance with the accompanying illustrations.

2.2.1 There are 22 types of temporary signs listed in the table below:

<b>Item</b>	<b>Description</b>	<b>Page</b>
T.1	Advance Warning Sign	81
T.2	Road Works Sign	82
T.3	Speed Limit Sign	82
T.4a	Part of Lane Closed to Traffic Sign	83
T.4b	Part of Lane Closed to Traffic Sign	83
T.4c	Part of Lane Closed to Traffic Sign	84
T.4d	Part of Lane Closed to Traffic Sign	84
T.5a	Road Narrow Sign	87
T.5b	Road Narrow Sign	87
T.6a	Detour Sign	88
T.6b	Detour Sign	88
T.6c	Detour Sign	89
T.6d	Detour Sign	89
T.7a	Keep Left Sign	90
T.7b	Keep Right Sign	90
T.8	Double Arrow Sign	91
T.9a	Sharp Deviation Sign	91
T.9b	Sharp Deviation Sign	91
T.10a	Left Bend Sign	92
T.10b	Right Bend Sign	92
T.11a	Chevron Delineator Sign	93
T.11b	Chevron Delineator Sign	93
T.12	Vertical Panel Sign	93
T.13	Material Piled by Roadside Sign	94
T.14a	"Stop" Sign	94
T.14b	'Go' Sign	94
T.15	'Awaw' Sign	95

<b>Item</b>	<b>Description</b>	<b>Page</b>
T.16	Danger Signs In Construction Areas	95
T.17	Road Works Sign (Work Area)	96
T.18a	Warning Sign "Symbol flagger"	96
T.18b	Warning Sign "LAMPU ISYARAT DIHADAPAN"	97
T.18c	Warning Sign "JENTERA DIHADAPAN"	97
T.18d	Warning Sign "LENCONGAN DIHADAPAN"	98
T.18e	Warning Sign "PEMBINAAN TAMAT"	98
T.19	Information Sign	99
T.20a	Directional Sign	100
T.20b	Directional Sign	100
T.21a	Apologetic Sign " HARAP MAAF KESULITAN AMAT DIKESALI"	101
T.21b	Apologetic Sign " KESABARAN ANDA AMAT DIHARGAI"	102
T.21c	Apologetic Sign " KERJASAMA ANDA AMAT DIHARGAI"	102

### 2.2.2 Height and Lateral Clearance of Temporary Signage

Minimum height and lateral clearance for signs attached to posts are shown in **Figure 2.1**. Signs on portable supports should be at least 0.3m away from the roadway. Signage locations and mounting heights may be adjusted to those above the minimum requirements to obtain good visibility.

## 2.2 Temporary Road Marking

Temporary road markings shall consist of continuous or intermittent lines, letters, arrows, symbols or figures. The markings shall be yellow in colour laid to the dimensions and at the locations shown in the Traffic Management Plan (TMP).

The temporary road marking shall either be of paint or thermoplastic material depending on the duration of the temporary works. The road marking paint shall be used for temporary road markings for less than 30 days construction period.

The thermoplastic material used shall be of the hot-applied thermoplastics and set on laying for temporary Work Zones of more than 30 days construction period. It is also recommended to be used in road with high traffic density.

### T.1 : ADVANCE WARNING SIGN

The sign should be placed in advance to warn the motorists of the construction areas.

**COLOUR :**

- Background - Fluorescent orange
- Border / Lettering - Black
- Background (distance) - White
- Background (service dept.) - Blue
- Lettering (service dept.) - White
- Distance indicator background - White

DIMENSIONS (mm)							
a	b	c	d	e	f	g	R
1524	1829	1174	350	100	200	150	75

**LETTERING :**

Ccrige Narrow

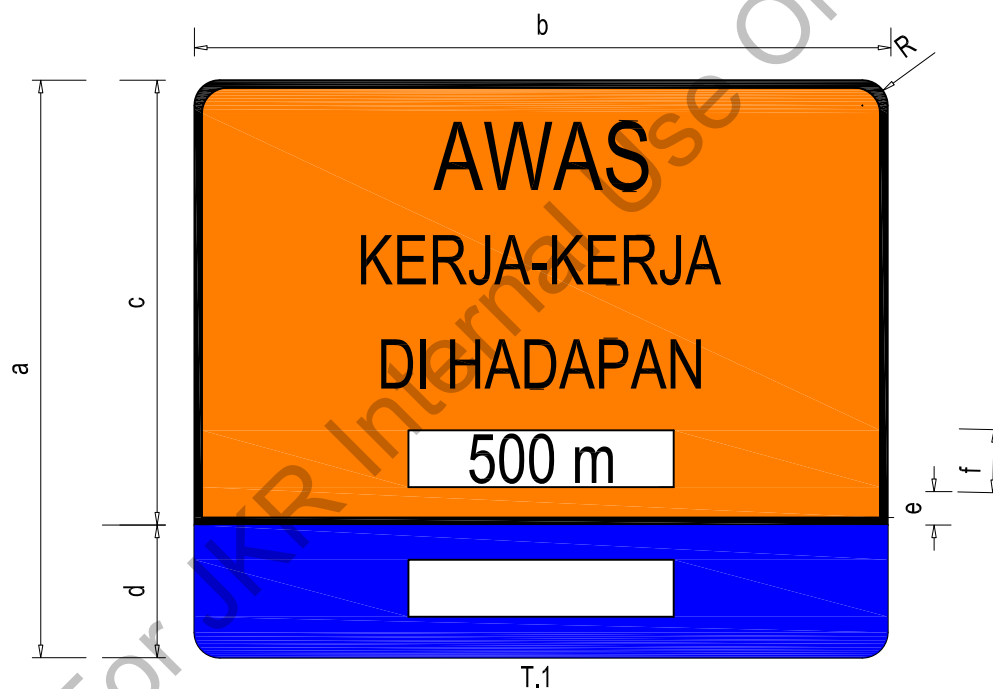

**Note:**

500 m is given as an example. The other distances are in between 250m until 2000m as recommended below:

- i. 2000m
- ii. 1000m
- iii. 500m
- iv. 400m
- v. 350m
- vi. 250m

The distance information should be in accordance to the Traffic Category.

Add the name of the agency at the bottom of the sign eg. JKR, DBKL, TNB, SYABAS, TM, MAXIS, IWK etc.



## PART TWO: TEMPORARY SIGNS

Scale : Not to scale

### T.2 : ROAD WORKS SIGN

Approach sign to any works on the road.

**COLOUR :**

- Background - Fluorescent orange
- Background (Symbol) - High Intensity Prismatic yellow
- Border - Black
- Symbol - Black
- Distance indicator background - White

DIMENSIONS (mm)							
a	b	c	d	e	f	g	R
1219	914	849	125	100	600	25	75

**LETTERING :**

Ccrige Narrow

Note:

400 m is given as an example. Distance varies from 200m until 1600m;

- i. 1600m
- ii. 800m
- iii. 400m
- iv. 300m
- v. 250m
- vi. 200m

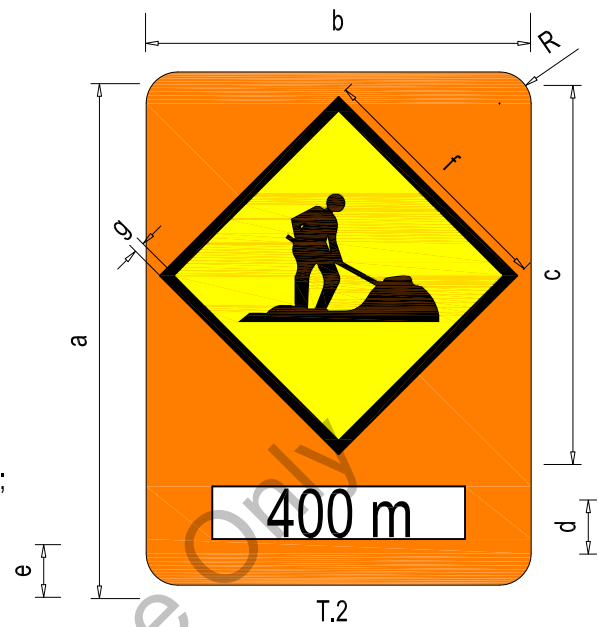

### T.3 : SPEED LIMIT SIGN

Approach sign that to warn motorists to maintain the speed limit at the construction area.

**COLOUR :**

- Background - Fluorescent orange
- Background (Symbol) - White
- Border - Red
- Symbol - Black

DIMENSIONS (mm)							
a	b	c	d	e	f	g	R
1219	914	750	125	100	250	125	75

**LETTERING :**

Ccrige Narrow

This is an example. Others speed are;

- i. 80 km/j
- ii. 70 km/j
- iii. 60 km/j
- iv. 50 km/j
- v. 40 km/j
- vi. 30 km/j

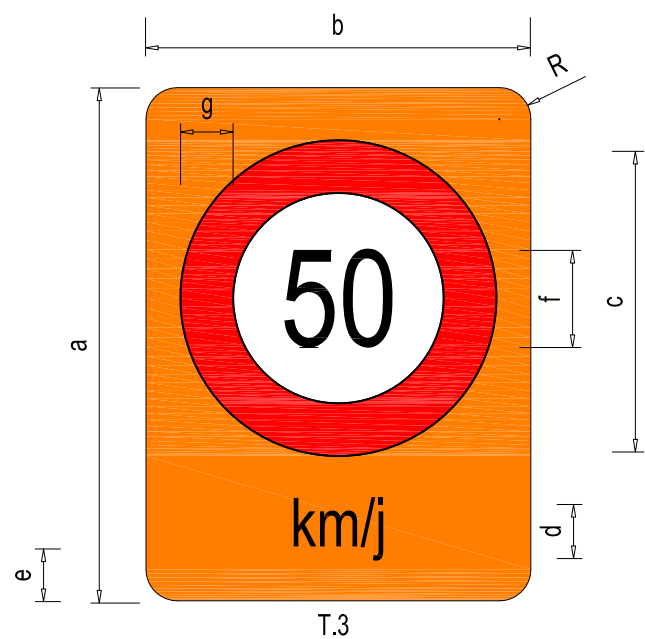

## PART TWO: TEMPORARY SIGNS

**T.4 : PART OF LANE CLOSED TO TRAFFIC SIGN**

- a. Approach sign to any works on the left hand side.
- b. Approach sign to any works on the right hand side.
- c. Approach sign for road narrowing either from left hand side or right hand side.
- d. Approach sign for road closure at ahead.
- e. Approach sign for road closure at left hand side .
- f. Approach sign for road closure at right hand side.

**COLOUR :**

- Background - Fluorescent orange
- Background (Symbol) - High Intensity Prismatic yellow
- Border - Black
- Symbol - Black with red bar for close lane
- Distance indicator background - White

DIMENSIONS (mm)					
a	b	c	d	e	R
1219	914	849	125	100	75

**LETTERING :**

Ccridge Narrow

The text 200m is the distance to the narrowed road and this distance varies from 200m until 1600m. This is an example;

- i. 1600m
- ii. 800m
- iii. 400m
- iv. 300m
- v. 250m
- vi. 200m

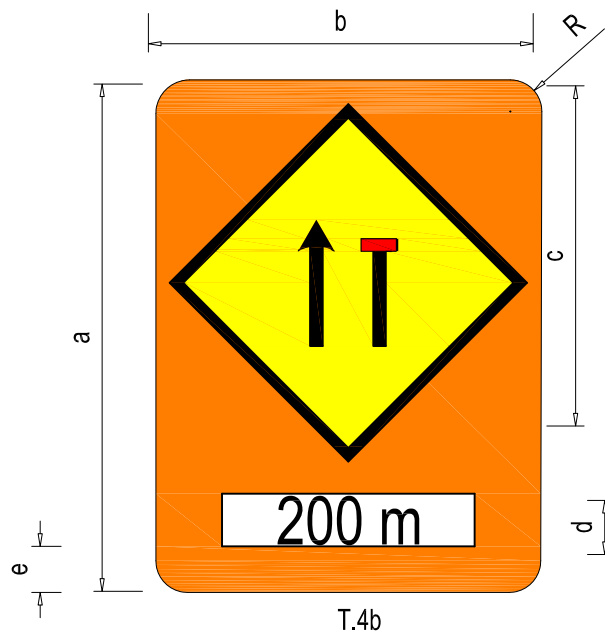
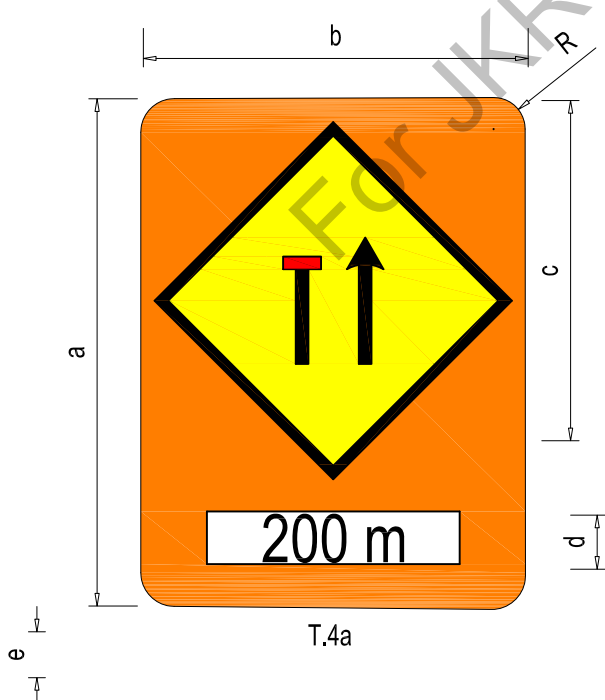

**PART TWO: TEMPORARY SIGNS**

Scale : Not to scale

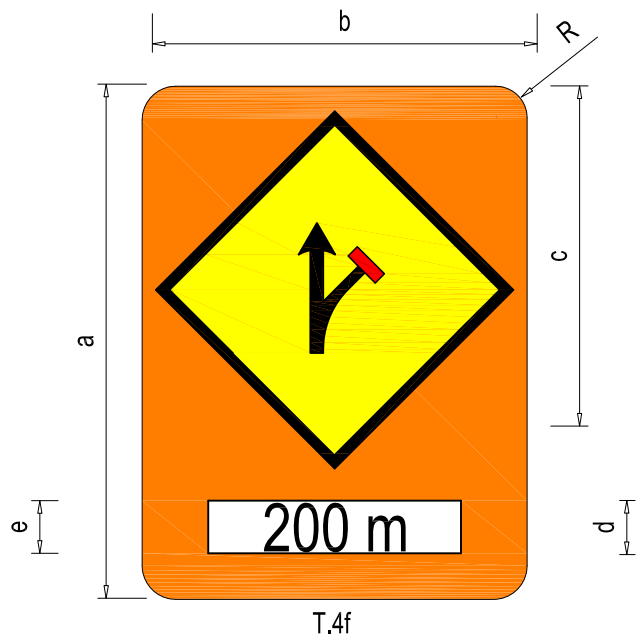
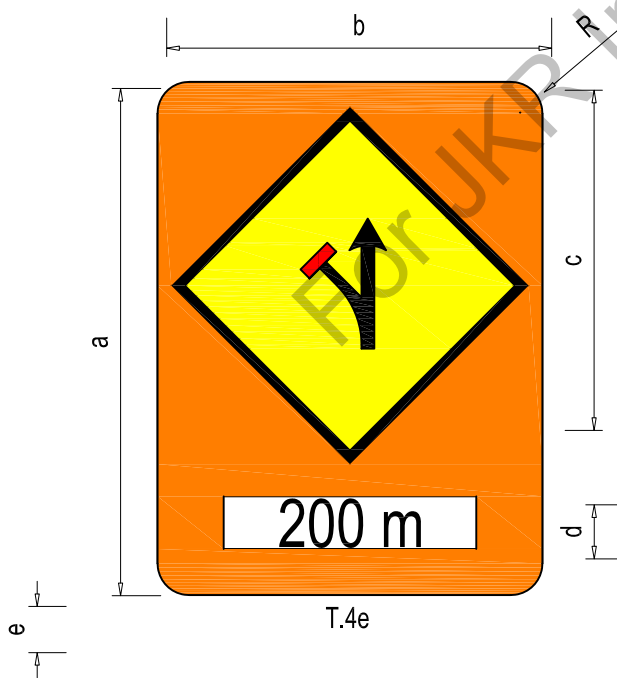
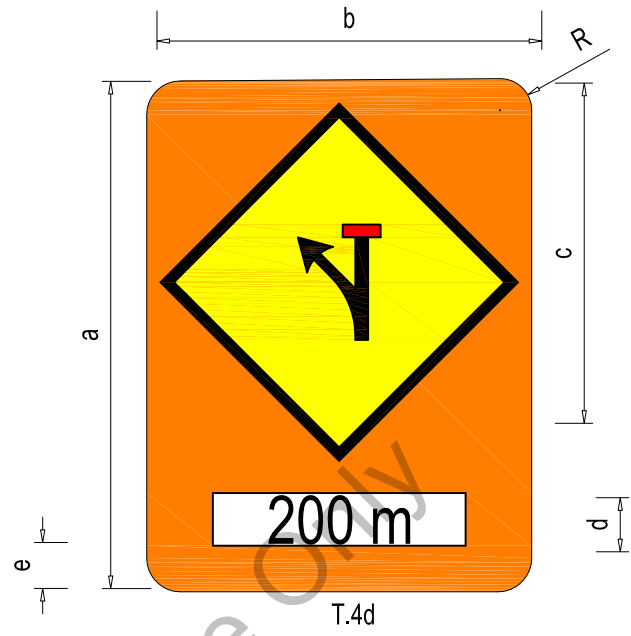
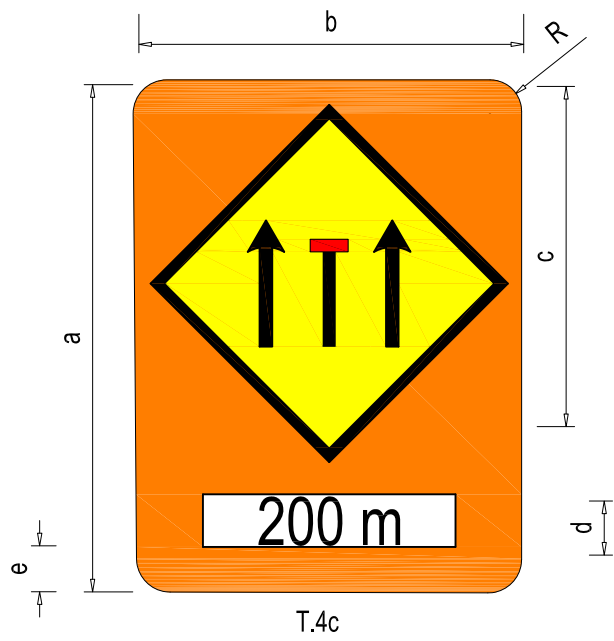

PART TWO: TEMPORARY SIGNS

Scale : Not to scale

DETAILS OF T.4a , T.4b & T.4c

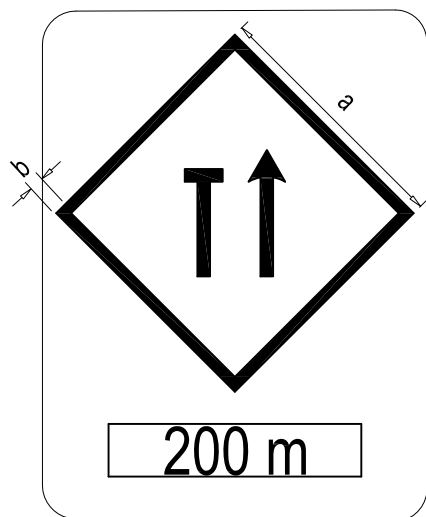

T.4a

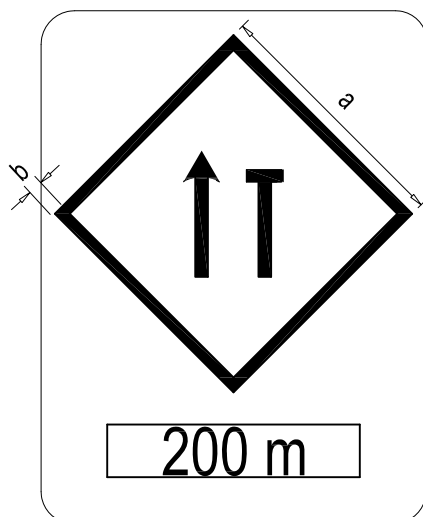

T.4b

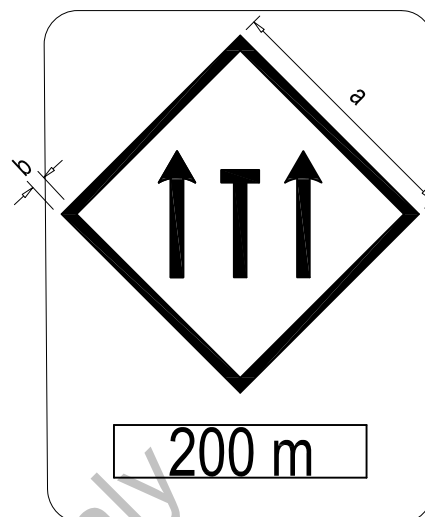

T.4c

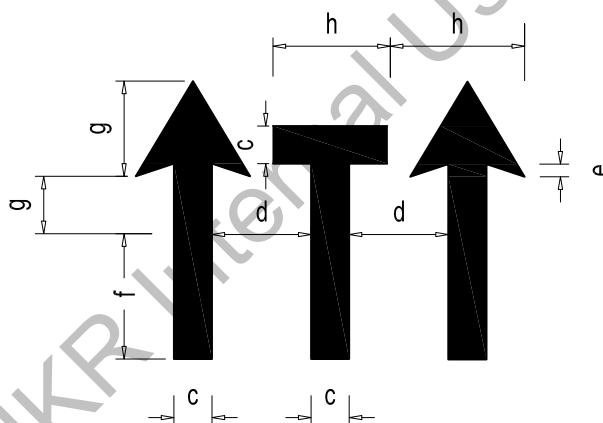

DIMENSIONS (mm)							
a	b	c	d	e	f	g	h
600	25	30	120	15	150	75	90



PART TWO: TEMPORARY SIGNS

DETAILS OF T.4d , T.4e & T.4f

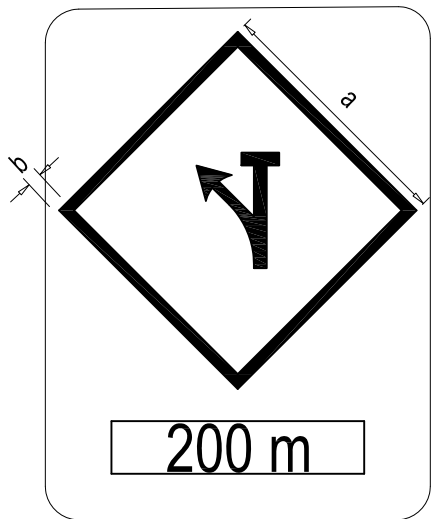

T.4d

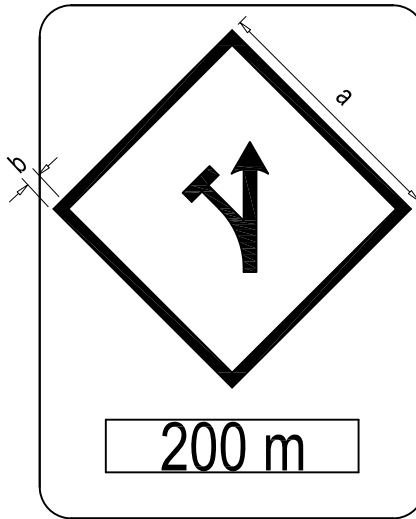

T.4e

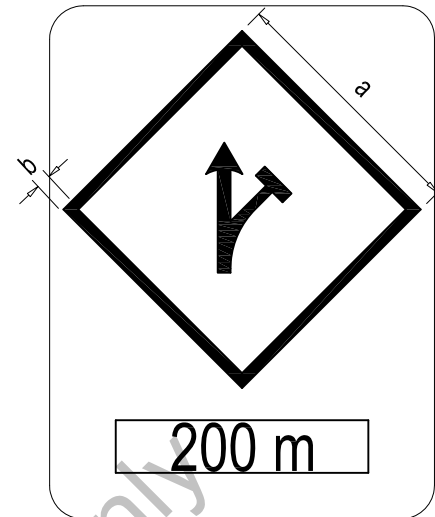

T.4f

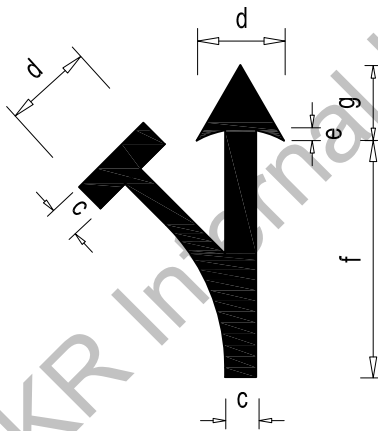

DIMENSIONS (mm)						
a	b	c	d	e	f	g
600	25	30	90	15	225	75



PART TWO: TEMPORARY SIGNS

T.5 : ROAD NARROW SIGN

Approach sign for road narrowing from left / right hand side.

COLOUR :

- Background - Fluorescent orange
- Background (Symbol) - High Intensity Prismatic yellow
- Border - Black
- Symbol - Black
- Distance indicator background - White

DIMENSIONS (mm)					
a	b	c	d	e	R
1219	914	849	125	100	75

LETTERING :

Ccrige Narrow

Distance varies from 100m until 1400m. This is an example;

- i. 1400m
- ii. 1000m
- iii. 600m
- iv. 400m
- v. 200m
- vi. 100m

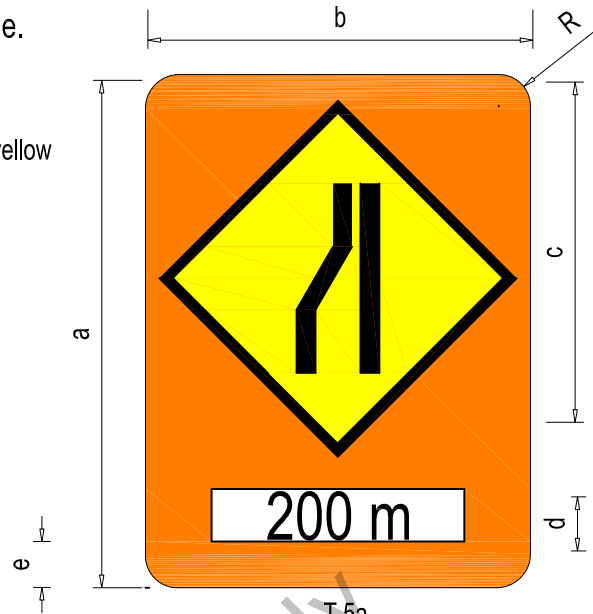

T.5a

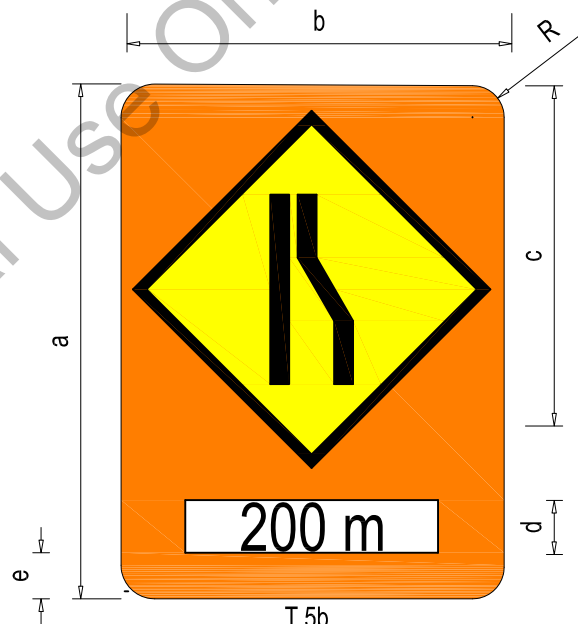

T.5b

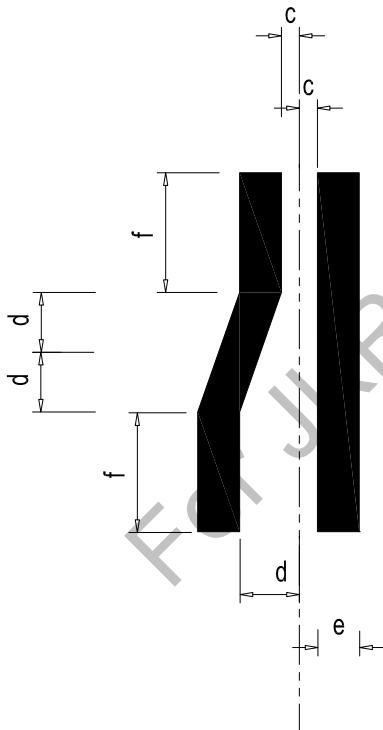

DIMENSIONS (mm)					
a	b	c	d	e	f
600	25	20	75	45	150



**T.6 : DETOUR SIGN**

This sign is used to show any detour or change in horizontal alignments at construction sites.

**COLOUR :**

- Background - Fluorescent orange
- Background (Symbol) - High Intensity Prismatic yellow
- Border - Black
- Symbol - Black
- Lettering - Black
- Distance indicator background - White

DIMENSIONS (mm)					
a	b	c	d	e	R
1219	914	849	125	100	75

**LETTERING :**

Ccrige Narrow

Distance varies from 100m until 1400m. This is an example;

- i. 1400m
- ii. 1000m
- iii. 600m
- iv. 400m
- v. 200m
- vi. 100m

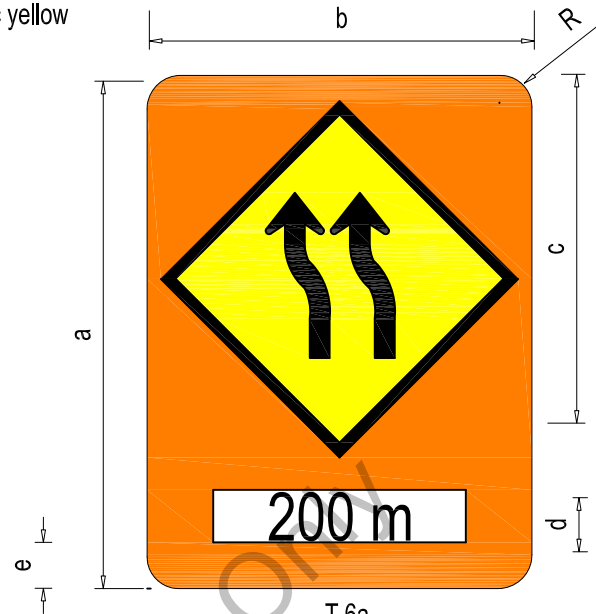

T.6a

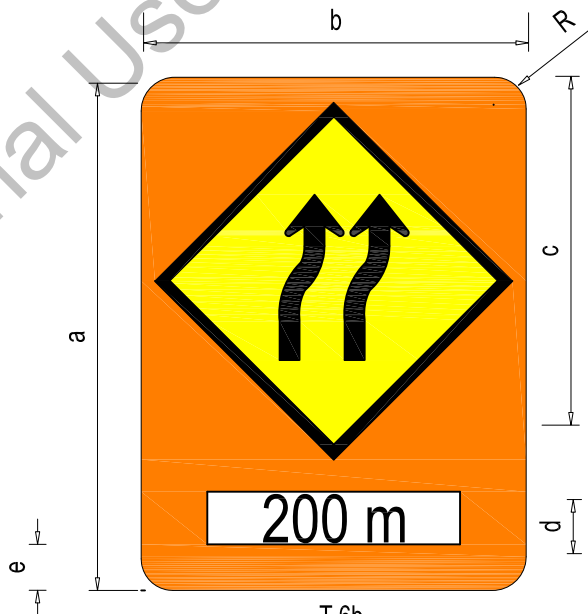

T.6b

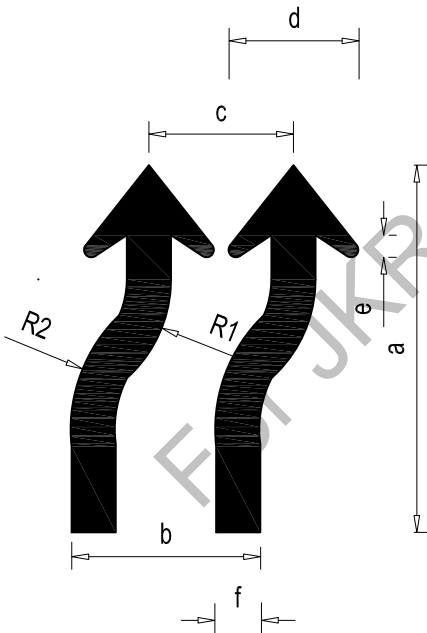

DIMENSIONS (mm)							
a	b	c	d	e	f	R1	R2
440	230	178	154	26	52	158	188



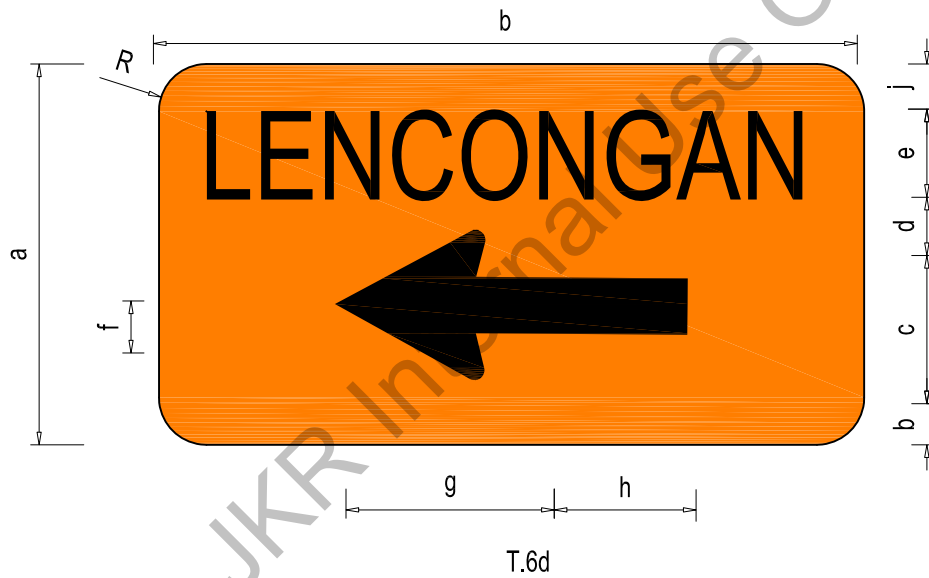
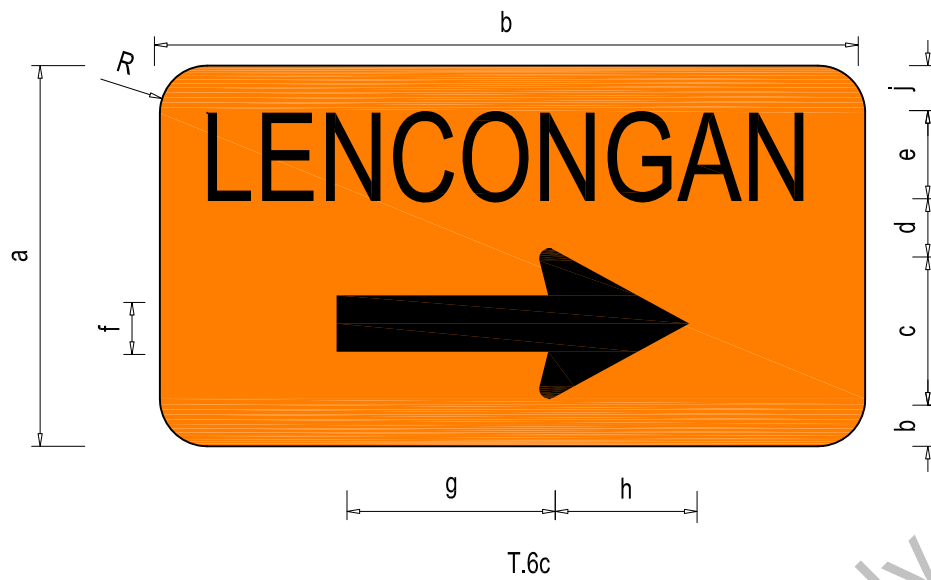

DIMENSIONS (mm)									
a	b	c	d	e	f	g	h	j	R
800	1500	280	100	200	100	500	250	120	75



PART TWO: TEMPORARY SIGNS

**T.7 : KEEP LEFT / RIGHT SIGN**

The sign indicate that the traffic is permitted to keep left / right .

**COLOUR :**

- Background - Fluorescent orange
- Background (Symbol) - Blue
- Symbol - White

DIMENSIONS (mm)			
a	b	c	R
914	750	82	75

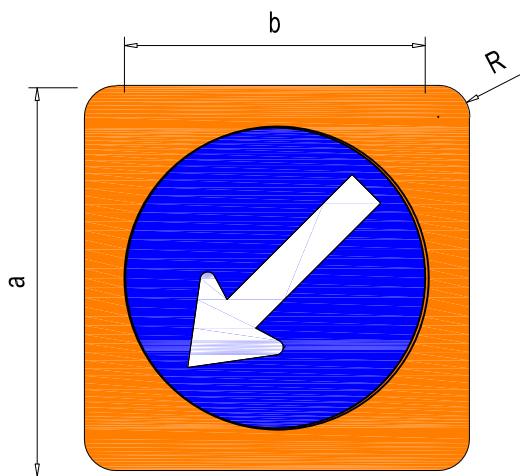

T.7a

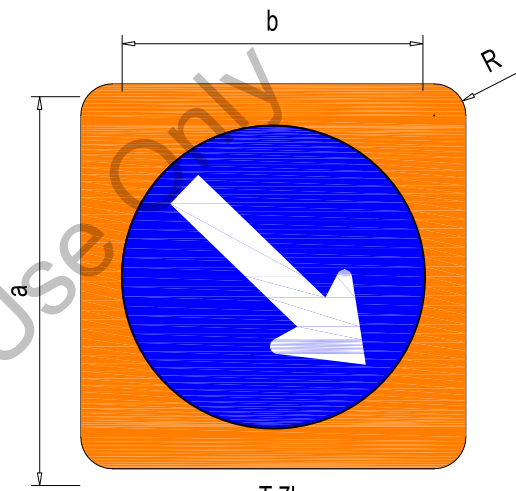

T.7b

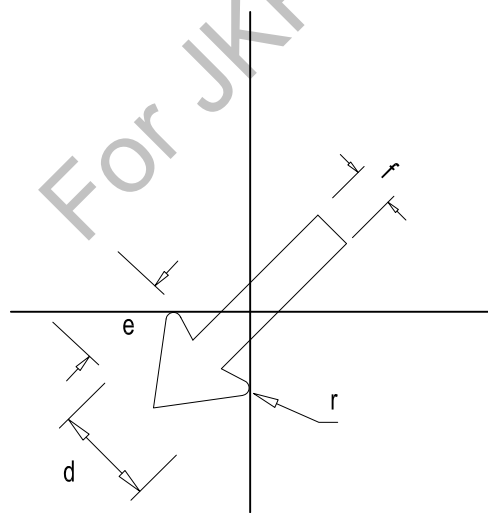

DIMENSIONS (mm)			
d	e	f	r
258	219	99	20



**PART TWO: TEMPORARY SIGNS**

### T.8 : DOUBLE ARROW SIGN

The sign indicate that the traffic is permitted to pass on either side of an island or any obstruction on a road.

**COLOUR :**

- Background - Fluorescent orange
- Background (Symbol) - High Intensity Prismatic yellow
- Border - Black
- Symbol - Black

DIMENSIONS (mm)		
a	b	R
914	914	75

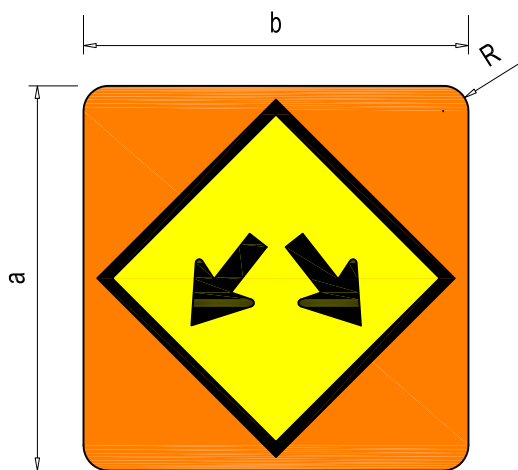

T.8

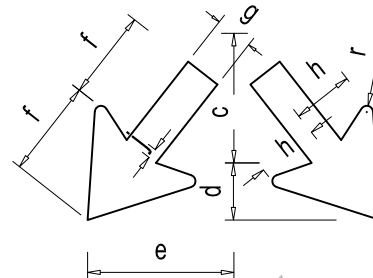

DIMENSIONS (mm)						
c	d	e	f	g	h	r
200	100	235	150	60	90	10

### T.9 : SHARP DEVIATION SIGN

The sign shall be used to show sharp deviation or sharp change in horizontal alignment.

**COLOUR :**

- Background - Fluorescent orange
- Border - Black
- Symbol - Black

DIMENSIONS (mm)					
a	b	c	d	e	R
400	1500	200	150	15	75

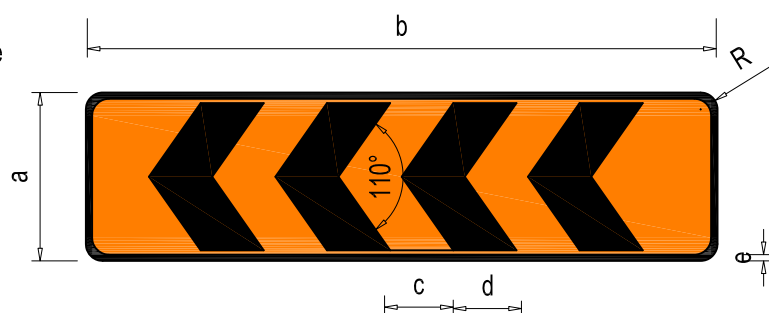

T.9a

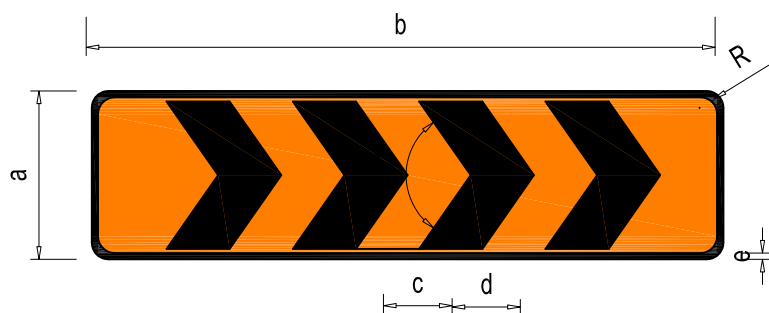

T.9b



## PART TWO: TEMPORARY SIGNS

### T.10 : LEFT / RIGHT BEND SIGN

Approach sign for the use on single bend which is dangerous owing to physical characteristics or reduced visibility to the left / right.

**COLOUR :**

- Background - Fluorescent orange
- Background (Symbol) - High Intensity Prismatic yellow
- Border - Black
- Symbol - Black

DIMENSIONS (mm)		
a	b	R
914	914	75

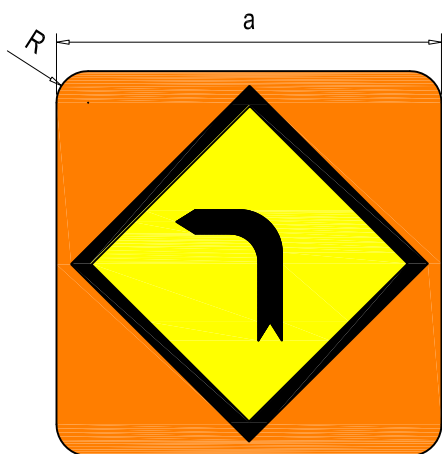

T.10a

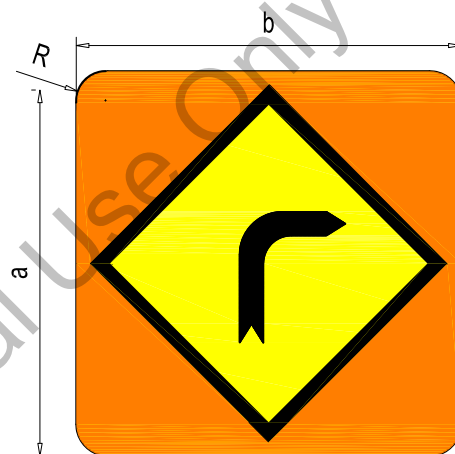

T.10b

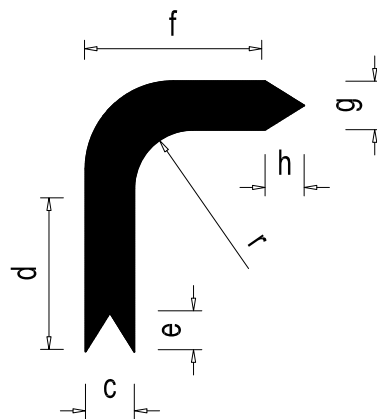

DIMENSIONS (mm)						
c	d	e	f	g	h	r
50	225	30	225	50	30	100



## PART TWO: TEMPORARY SIGNS

**T.11 : CHEVRON DELINEATOR SIGN**

Sign to indicate a hazardous change in horizontal and vertical alignment both combined.

**COLOUR :**

- Background - Fluorescent orange
- Border - Black
- Symbol - Black

	DIMENSIONS (mm)		
	900mm x 750mm	750mm x 600mm	600mm x 450mm
a	375	300	210
b	25	15	10
c	20	15	10
d	20	20	15
R	95	75	60

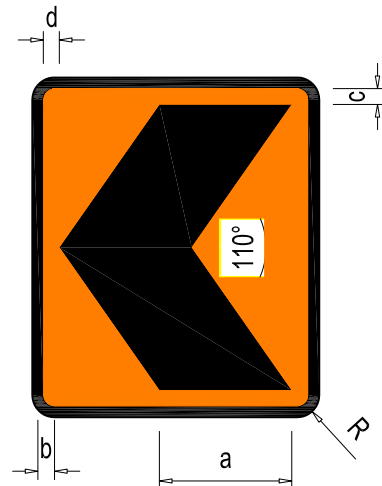

T.11a

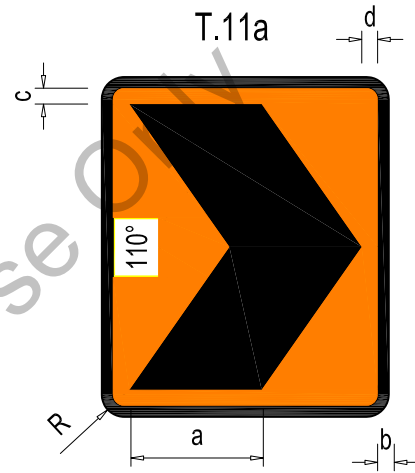

T.11b

**T.12 : VERTICAL PANEL SIGN**

This panel is used to delineate at the construction and maintenance sites where roadway clearance is less than the width of the pavement on the approach.

**COLOUR :**

- Background - White
- Stripe - Engineering grade orange

DIMENSIONS (mm)				
a	b	c	d	R
900	300	125	150	40

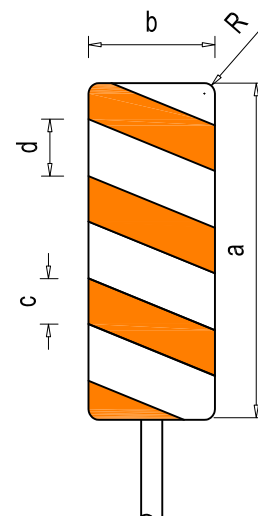

T.12



**PART TWO: TEMPORARY SIGNS**

**T.13 : MATERIAL PILED BY ROADSIDE SIGN**

Approach sign to areas where material such as earth, aggregate, etc. is piled by the roadside.

- COLOUR :**
- Background                                 - Fluorescent orange
  - Background (Symbol)                 - High Intensity Prismatic yellow
  - Border                                       - Black
  - Symbol                                       - Black

DIMENSIONS (mm)				
a	b	c	d	R
914	914	600	25	75

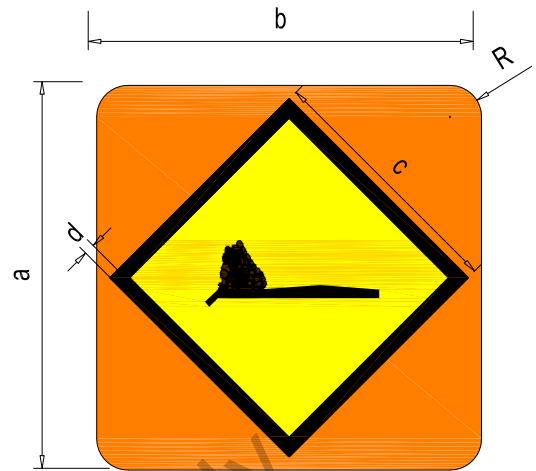

T.13

**T.14 : STOP / GO SIGN**

Temporary control paddle sign used to control the traffic flow .

- COLOUR :**
- Background                                 - Fluorescent orange
  - Symbol                                       - Red in reverse / green on obverse
  - Border                                       - Black

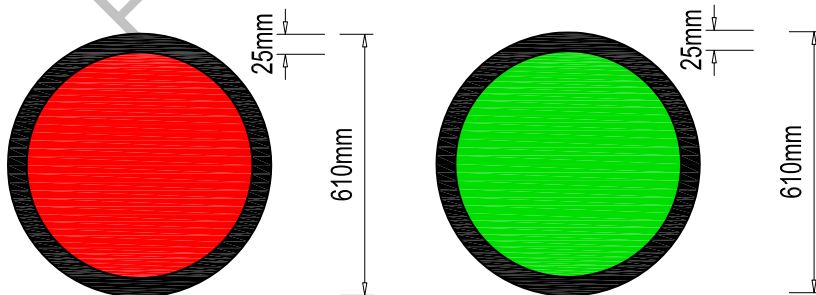

T.14a

T.14b



**PART TWO: TEMPORARY SIGNS**

T.15 : AWAS SIGN

Approach sign indicating some sort of danger ahead other than the danger warning signs available. An additional rectangular panel bearing an inscription or symbol indicating the nature of the danger ahead may be placed underneath this sign.

SIGNS	DIMENSIONS (mm)				
	a	b	c	d	R
Minimum	500	1000	15	300	65

COLOUR :

- Background - Fluorescent orange
- Border - Black
- Lettering - Black

LETTERING :

Ccridge Narrow

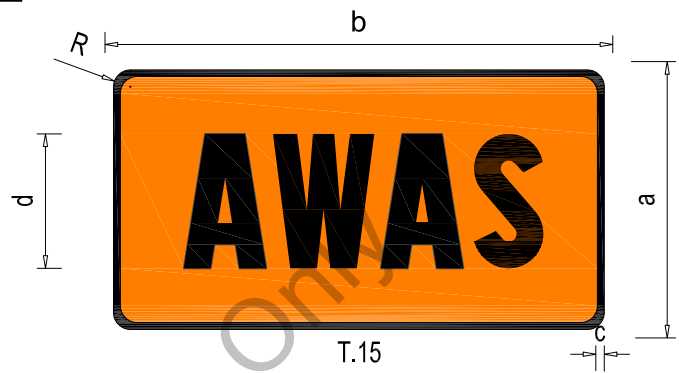

T.16 : DANGER SIGNS IN CONSTRUCTION AREAS

These signs shall be placed at appropriate location to warn motorist of any danger ahead other than the danger warning signs available. An additional rectangular panel bearing an inscription or symbol indicating the nature of the danger ahead may be placed underneath this sign.

COLOUR :

- Background - Fluorescent orange
- Background (Symbol) - High intensity prismatic yellow
- Border - Black
- Symbol - Black

DIMENSIONS (mm)				
a	b	c	d	R
914	914	600	25	75

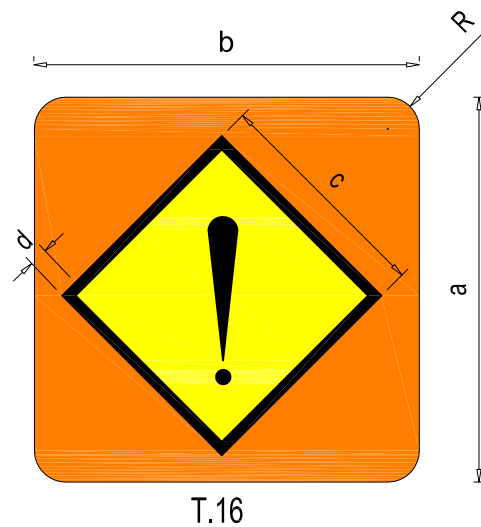

PART TWO: TEMPORARY SIGNS

**T.17 : ROAD WORKS SIGN (WORK AREA)**

Approach sign to any works on the road.

**COLOUR :**

- Background - Fluorescent orange
- Background (Symbol) - High Intensity Prismatic yellow
- Border - Black
- Symbol - Black

DIMENSIONS (mm)				
a	b	c	d	R
914	914	600	25	75

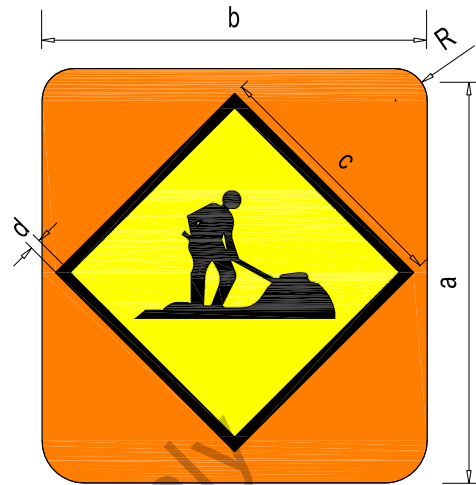

T.17

**T.18 : WARNING SIGN**

a. This sign indicate that there is a flagger position ahead of construction area.

**COLOUR :**

- Background - Fluorescent orange
- Background (Symbol) - High intensity prismatic yellow
- Border - Black
- Symbol - Black
- Distance indicator background - White

DIMENSIONS (mm)								
a	b	c	d	e	f	g	R	
1219	914	849	125	100	600	25	75	

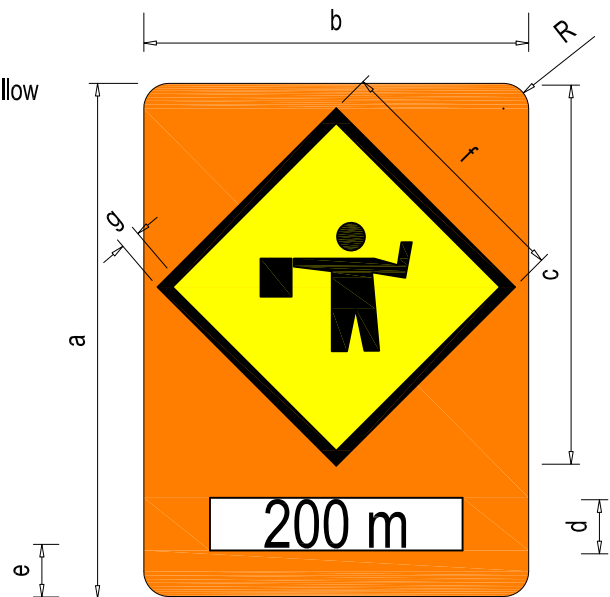

T.18a

**LETTERING :**

Ccrige Narrow

The text 200m is the distance to the flagger position and this distance varies from 200m until 1600m. This is an example;

- a. 200m
- b. 100m



**PART TWO: TEMPORARY SIGNS**

b. This signs with appropriate messages shall be placed at appropriate locations in a construction site.

**COLOUR :**

- Background - Fluorescent orange
- Border - Black
- Lettering - Black
- Distance indicator background - White

DIMENSIONS (mm)						
a	b	c	d	e	f	R
800	1200	20	55	125	50	75

**LETTERING :**

Ccrige Narrow

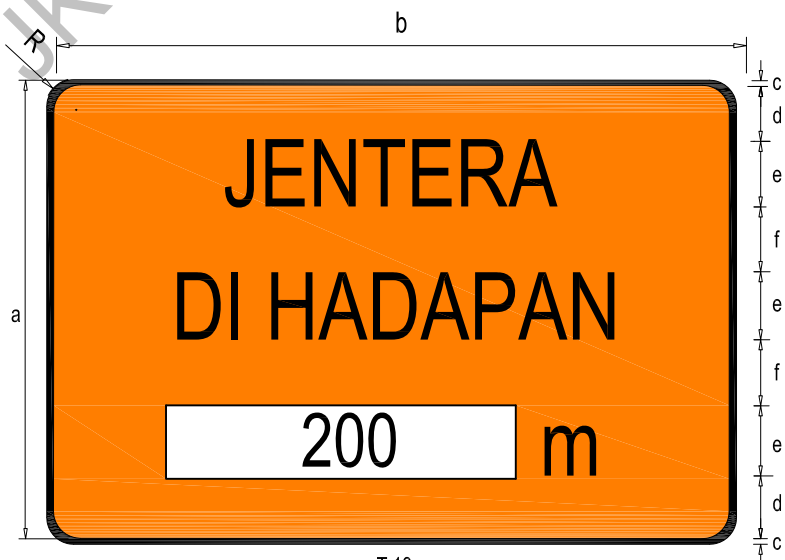
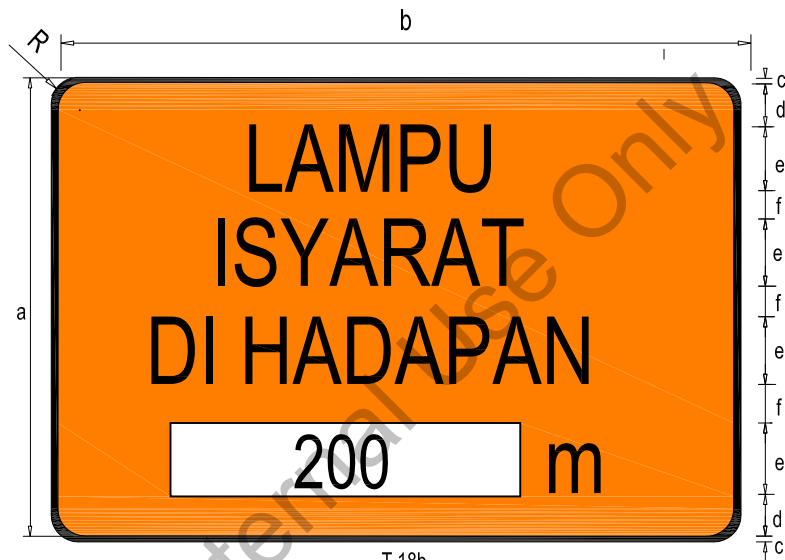

**PART TWO: TEMPORARY SIGNS**

Scale : Not to scale

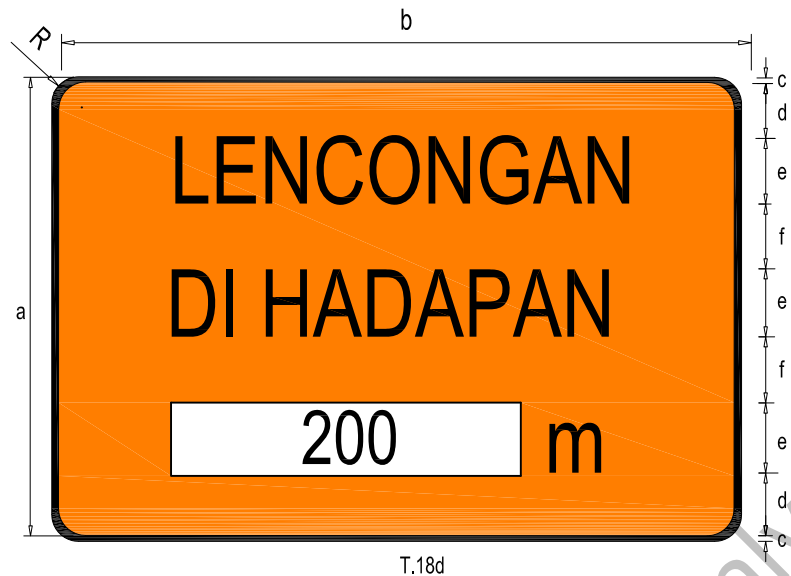

T.18d

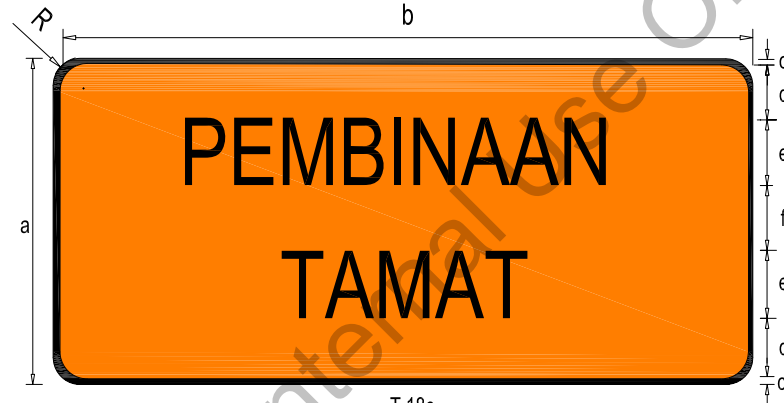

T.18e

DIMENSIONS (mm)						
a	b	c	d	e	f	R
800	1200	20	117.5	125	75	75



PART TWO: TEMPORARY SIGNS

**T.19 : INFORMATION SIGN**

**COLOUR:**

- Background - Fluorescent orange
- Lettering - Black
- Border - Black

**LETTERING:**

Ccridge Narrow

DIMENSIONS (mm)					
a	b	c	d	e	R
112.5	150	125	93.75	20	75



T.19



**PART TWO: TEMPORARY SIGNS**

Scale : Not to scale

T.20 : DIRECTIONAL SIGN

COLOUR:

- Background - Fluorescent orange
- Lettering - Black
- Border - Black

LETTERING:

Ccrlge Narrow

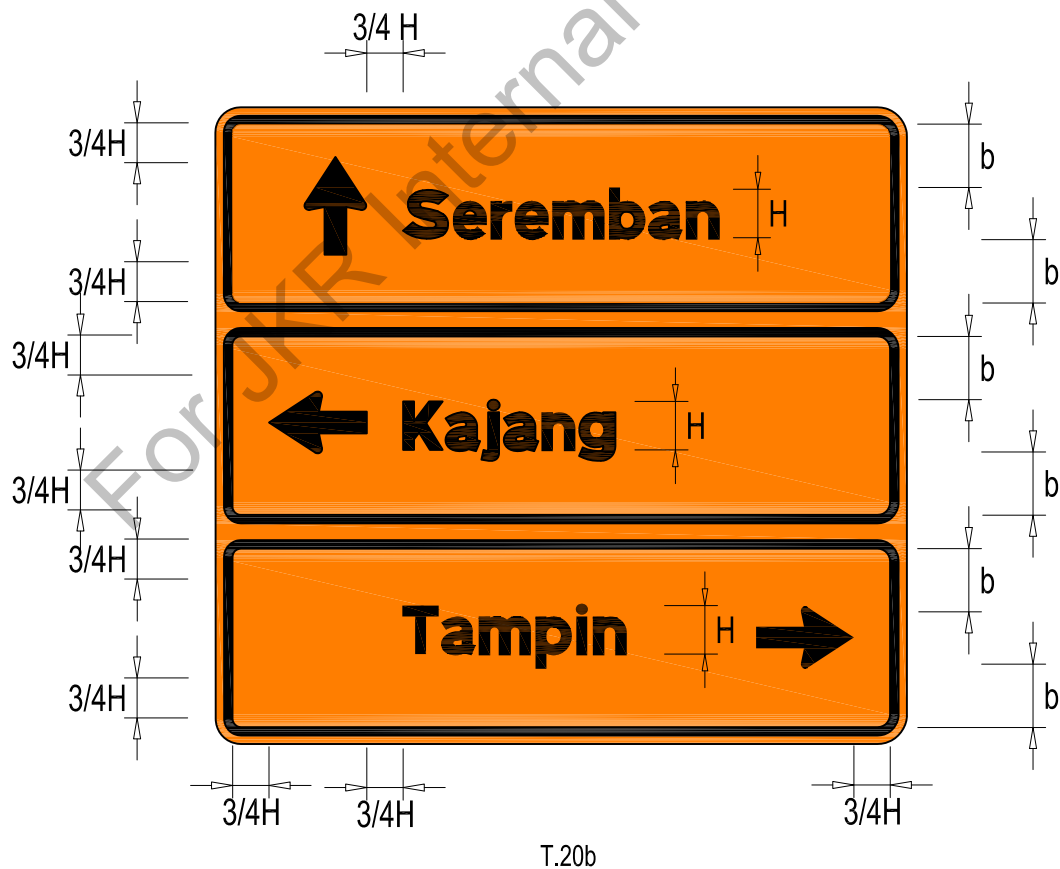
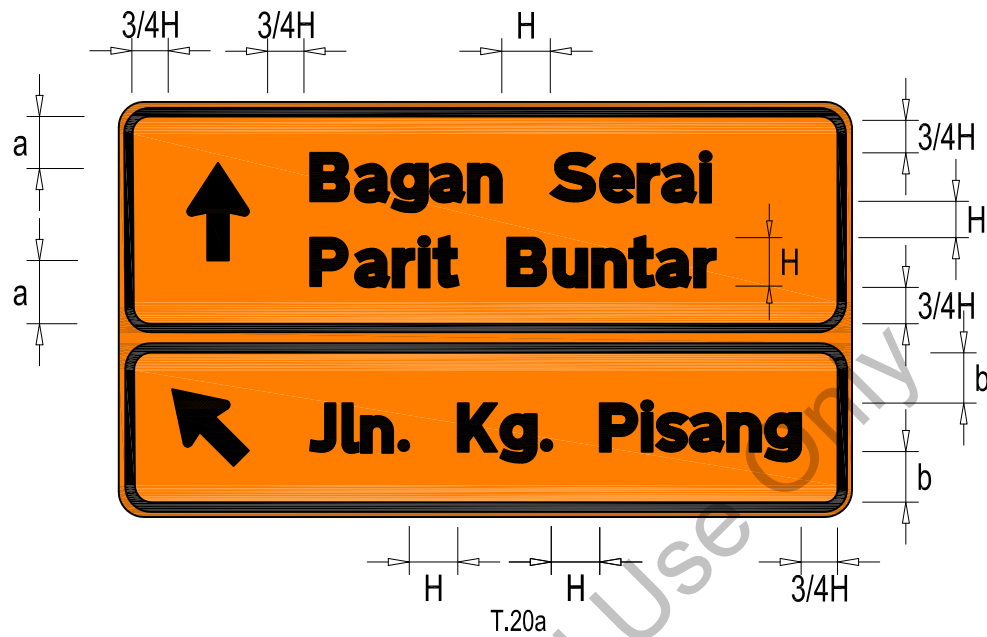

LEGEND :

- H = 150mm
- a & b = Distance showing that words or symbols must be centralised



PART TWO: TEMPORARY SIGNS

Scale : Not to scale

## T.21 : APOLOGETIC SIGNS

These signs with appropriate messages shall be placed at appropriate locations in a construction site.

### COLOUR:

Background - Fluorescent orange  
 Lettering - Black  
 Border - Black

### LETTERING:

Ccrige Narrow

DIMENSIONS (mm)				
a	b	c	d	e
700	1200	20	90	100



This is an example. The following are the messages that can be used according to the requirements of the construction area:

1. KESABARAN ANDA AMAT DIHARGAI
2. KERJASAMA ANDA AMAT DIHARGAI



DIMENSIONS (mm)				
a	b	c	d	e
700	1200	20	90	100



T.21b

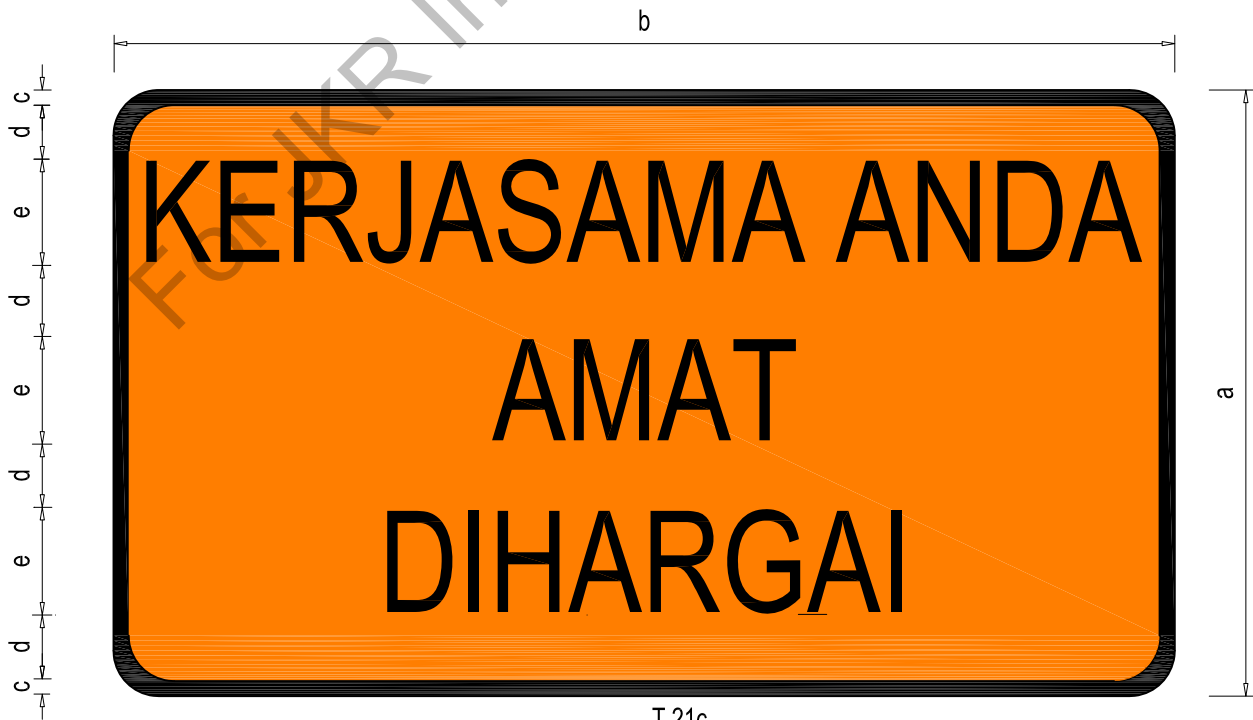

T.21c



PART TWO: TEMPORARY SIGNS

ROADSIDE SIGN  
RURAL DISTRICT

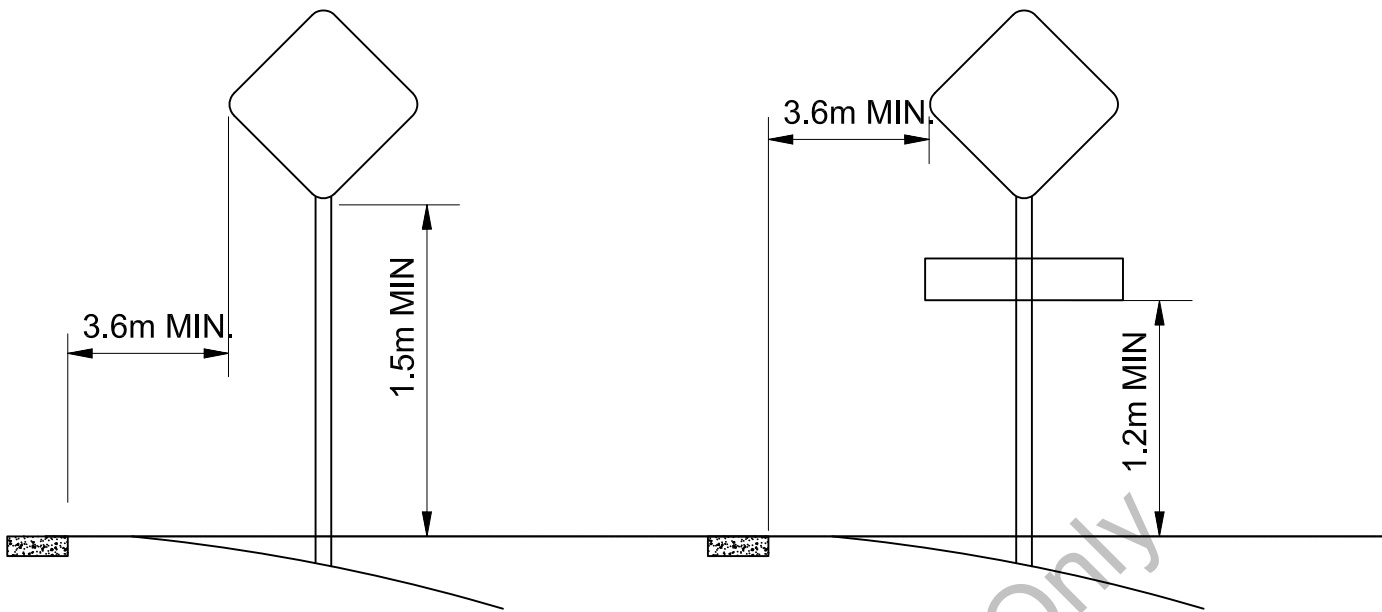

WITH ADVISORY SPEED PLATE

ROADSIDE SIGN  
URBAN DISTRICT

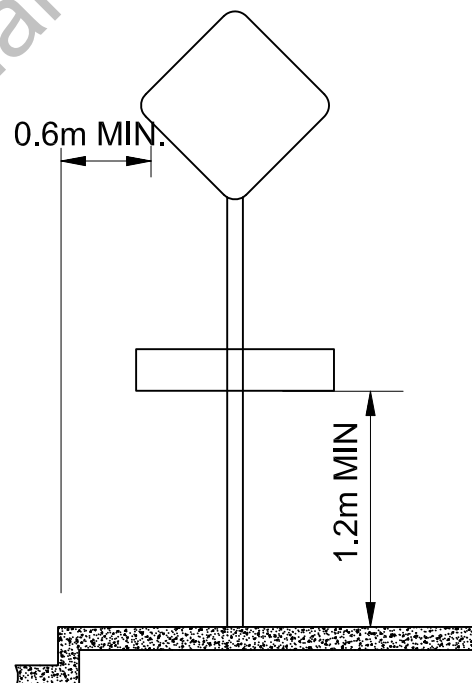
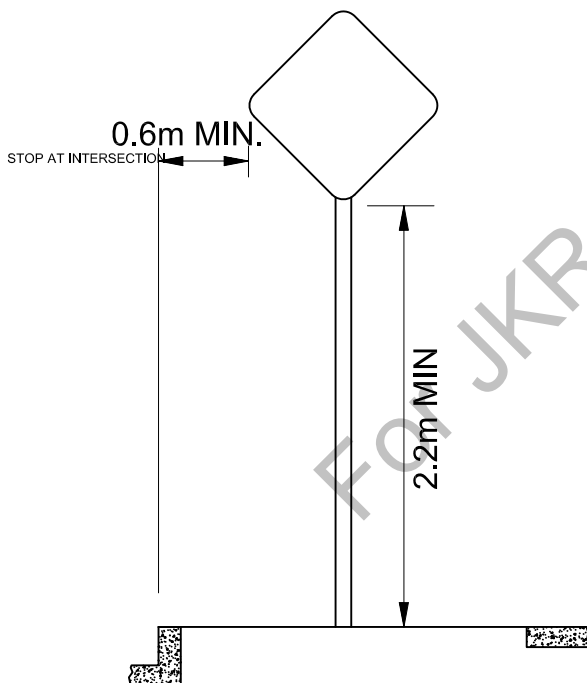

WITH ADVISORY SPEED PLATE

FIGURE 2.1: HEIGHT AND LATERAL LOCATION OF SIGNS  
SIGNS TYPICAL INSTALLATION



## 2.3 Temporary Management Equipment

In addition to temporary signs, other forms of temporary management equipment shall be used for guiding, warning and channelizing of traffic throughout the work zone.

### 2.3.1 Type of Traffic Management Equipment

There are various types of Traffic Management Equipment listed in the table below:

Item	Description	Page
1	Traffic Guidance Cone	112
2	Traffic Super Cone	112
3	Plastic Barrier	113
4	Concrete Barrier	114
5	Plastic Hoarding	115
6	Delineator String	116
7	Flashing Light (Blinker)	116
8	Flashing Arrow	117
9	Chevron Light	118
10	Variable Messaging System (VMS)	119
11	Delineator on Barrier	120
12	Traffic Control Paddle	121
13	Traffic Baton Light	121

### 2.3.2 Application Requirements

#### 2.3.2.1 Traffic Guidance Cone

- (a) Traffic guidance cones shall be used at Buffer Area, Work Area and Termination Area during temporary lane closure or road diversion of less than 24 hours duration. Blinkers must be installed on traffic guidance cones at the required spacing during lane closure or road diversion at night.
- (b) Traffic guidance cones shall be at 15m spacing throughout Traffic Control Zones.

#### 2.3.2.2 Traffic Super Cone

- (a) Traffic super cones shall be used for tapering at the Transition Area during lane closure or road diversion with a spacing of 5m.

#### 2.3.2.3 Plastic Barrier

- (a) Serve as channelizing and guiding device to road users rather than as a safety barrier that can contain vehicle when hit.
- (b) The barrier shall be used at excavation work area if depth is less than 1m. Minimum 1m lateral clearance to be

provided from edge of barrier to the excavated area and concrete barrier to be used if otherwise.

- (c) Plastic barriers shall be arranged in alternate colours of red and white and must be interlocked.

#### 2.3.2.4 Concrete Barrier

- (a) Serve as safety barrier to road users and shall be used at excavation work with depth 1m or more and a minimum 0.6m lateral clearance to be provided from edge of barrier to the excavated area.
- (b) Concrete barriers shall also be placed at the following critical locations:
  - (i) Replacing an existing permanent safety feature that has been removed such as guardrails, bridge railings, median barrier etc.
  - (ii) Located close to rigid objects such as sheet piling, bridge structures, stockpiles etc.
  - (iii) Sharp and dangerous corners.
  - (iv) Flood prone areas.
  - (v) Slope failure or sinkhole and if there are any visible hazards that can cause dangers to the public such as heavy machineries.
- (c) Concrete barriers shall be arranged in alternate colours of black and yellow and must be interlocked.

#### 2.3.2.5 Plastic Hoarding

- (a) Plastic hoardings on barriers shall be placed at work area where the view of activities is to be blocked. This is to prevent distraction to the traffic.

#### 2.3.2.6 Delineator string

- (a) Delineator string shall be installed along Work Area next to a road.
- (b) Delineator string shall be installed with minimum height 1m from the ground level and mounted to wooden post (25mm x 25mm) with 3m spacing interval.

#### 2.3.2.7 Flashing Light (Blinker)

- (a) Blinkers shall be installed on traffic guidance cones, barriers or hoardings every 30m c/c at straight and 10m c/c at taper or curve to allow drivers enough time to alter their driving pattern.

#### 2.3.2.8 Beacon Light

- (a) During normal daytime maintenance operations, the functions of flashing beacons are adequately provided for by the lighting equipment on maintenance vehicles, either emergency flasher, the rotating dome light, or both. However, at locations where the daytime maintenance activity requires an obstruction to remain in the roadway at night, flashing beacons may be installed at the point of hazard.
- (b) Beacon Light may be operated singly or in groups containing more than one unit and they are brighter than blinker lights.

#### 2.3.2.9 Flashing Arrow

- (a) Flashing arrow shall be installed at Transition Area for tapering (with 3 nos. of arrow signboard and can be combined with chevron light when necessary) during night lane closure.

#### 2.3.2.10 Chevron Light

- (a) Chevron lights shall be installed at Transition Area for tapering (min 3 nos.) and can be combined with flashing arrow during night lane closure.

#### 2.3.2.11 Variable Messaging System (VMS)

- (a) The VMS shall be installed at a max. distance of 500m before any work area which involves frequent change of information to the road user.
- (b) VMS to be fully operational at all times and necessary backup power supply to be provided to ensure its continuous operation.

#### 2.3.2.12 Delineators on Barrier

- (a) Delineators shall be installed at every interlocked plastic and concrete barrier. Fluorescent Orange reflective sheeting shall be visible to the traffic.
- (b) To be installed at the front centre of barrier at minimum 750mm height from ground level.

#### 2.3.2.13 Robotic Flagman

- (a) Robotic flagman shall be able to work for a duration of 24 hours operation.
- (b) The location to be installed is immediately within the Transition Area.
- (a) Robotic flagman shall be deployed for both the short term and long term at work area.

#### 2.3.2.14 Traffic Control Paddle

- (a) Traffic control paddle shall be used by flagman to control traffic during daytime operations.
- (b) Method of using traffic control paddle to be the same as flagging method.
- (c) Flagger Guidelines
  - (i) For short work areas where both ends can be seen at the same time, only one flagger is needed. Both directions of traffic must be able to see the flagger and to recognize the person as a flagger. If this is not possible with one flagger, use two.
  - (ii) Flaggers should be visible, always face traffic and be prepared to warn workers to get out of the way if necessary. Do not allow other workers to gather near the flagger. During lunch or other breaks, flaggers should leave their station so that drivers will know that the flaggers are not on duty and not think they are shirking their duties whilst having their lunch or break if flaggers act otherwise.
  - (iii) Whenever a flagger is on duty, the advance flagger sign should be displayed to traffic. When a flagger is not on duty, remove or cover the sign.
  - (iv) Flaggers may use either a red, 600mm square flag or 600mm diameter circular Stop-Go paddle. (see **Figures 2.2** and **2.3**).
  - (v) Flagger for flagging has to be an experienced/trained person so as not to cause any inconvenience to the traffic flow. It is advisable that the flagger be given proper courses on flagging procedures.

(d) Flagging Procedures

(i) To Stop Traffic

The flagger shall face traffic and extend the flag horizontally across the traffic lane in a stationary position so that the full area of the flag is visible hanging below the staff. For greater emphasis, the free arm may be raised with the palm towards the approaching traffic. **(Figure 2.2)**.

(ii) Traffic to Proceed.

The flagger shall stand parallel to the traffic movement and with flag and arm lowered from view of the driver, then motion traffic ahead with his free arm. Flags shall not be used to signal traffic to proceed. **(Figure 2.2)**.

(iii) To Slow Traffic

Where it is desired to alert or slow down traffic by means of flagging, the flagger shall face traffic and slowly wave the flag in a sweeping motion of the extended arm from the shoulder level to straight down without raising the arm above a horizontal position. **(Figure 2.2)**.

2.3.2.15 Traffic Baton Light

(a) Traffic baton light shall be used by flagman to control traffic during night time operations.

(b) Method of using traffic baton light to be the same as flagging method in 2.3.2.14(d) of this guidelines.

2.3.2.16 Traffic Management Deployment Team (TMDT) Lorry

(a) Lorry shall be provided by the Contractor for setting up and maintaining traffic control devices for day and night operations.

(b) The lorry shall be a minimum 1 tonne lorry with cargo hood and grill. The lorry shall be white in colour.

(c) TMDT lorry shall be used to ferry workers and/or traffic management devices.

- 2.3.2.17 Roof Mounted LED Arrow Light (Accessories for TMDT Lorry)
- (a) The LED arrow light shall be mounted on TMDT lorry rooftop with collapsible holder to secure the arrow light board during operations.
  - (b) LED arrow light shall be used when the TMDT lorry carries out its duty at work area.
- 2.3.2.18 Emergency Response Team (ERT) Lorry
- (a) The lorry shall be a minimum 1 tonne lorry with cargo hood. The lorry shall be white in colour.
  - (b) ERT lorry shall be provided by the Contractor to the Traffic ERT for patrolling and attending to emergency needs and situations for day and night operations.
  - (c) The response time to reach affected area and initiate necessary action shall not be more than 30 minutes.
  - (d) ERT lorry vehicle is strictly for the use of ERT personnel only and its use to ferry workers is strictly prohibited.
- 2.3.2.19 Emergency Response Team (ERT) Equipment
- (a) The Contractor shall provide the following ERT equipment which shall either be in the ERT lorry at all times or properly stored away and ready to be moved and used at any time, as and when required:
  - (b) Equipment inside the ERT lorry shall be stored properly at all times to ease the handling and installation process when attending to emergency needs and situations.
  - (c) All ERT equipment shall be well maintained throughout the project duration to ensure that they are in good working condition.

FLAG

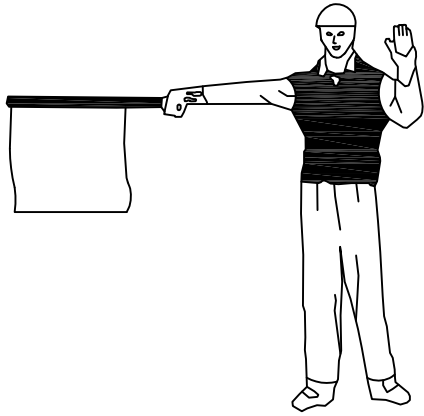

PADDLE

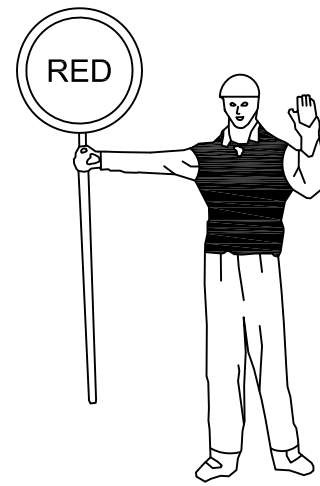

TO STOP  
TRAFFIC



TRAFFIC  
PROCEED

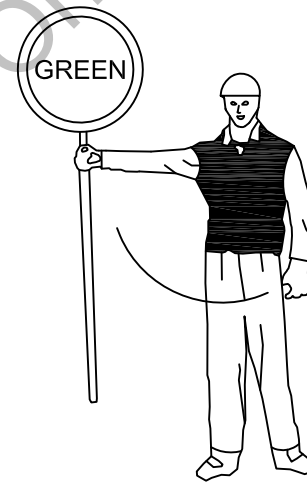

TO ALERT  
AND SLOW  
TRAFFIC

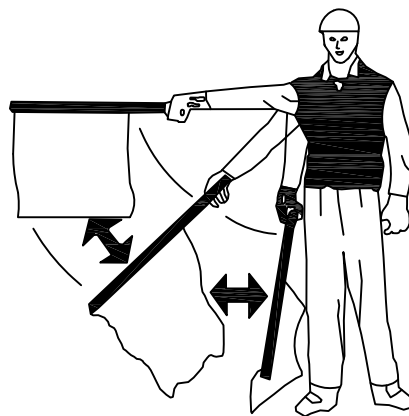
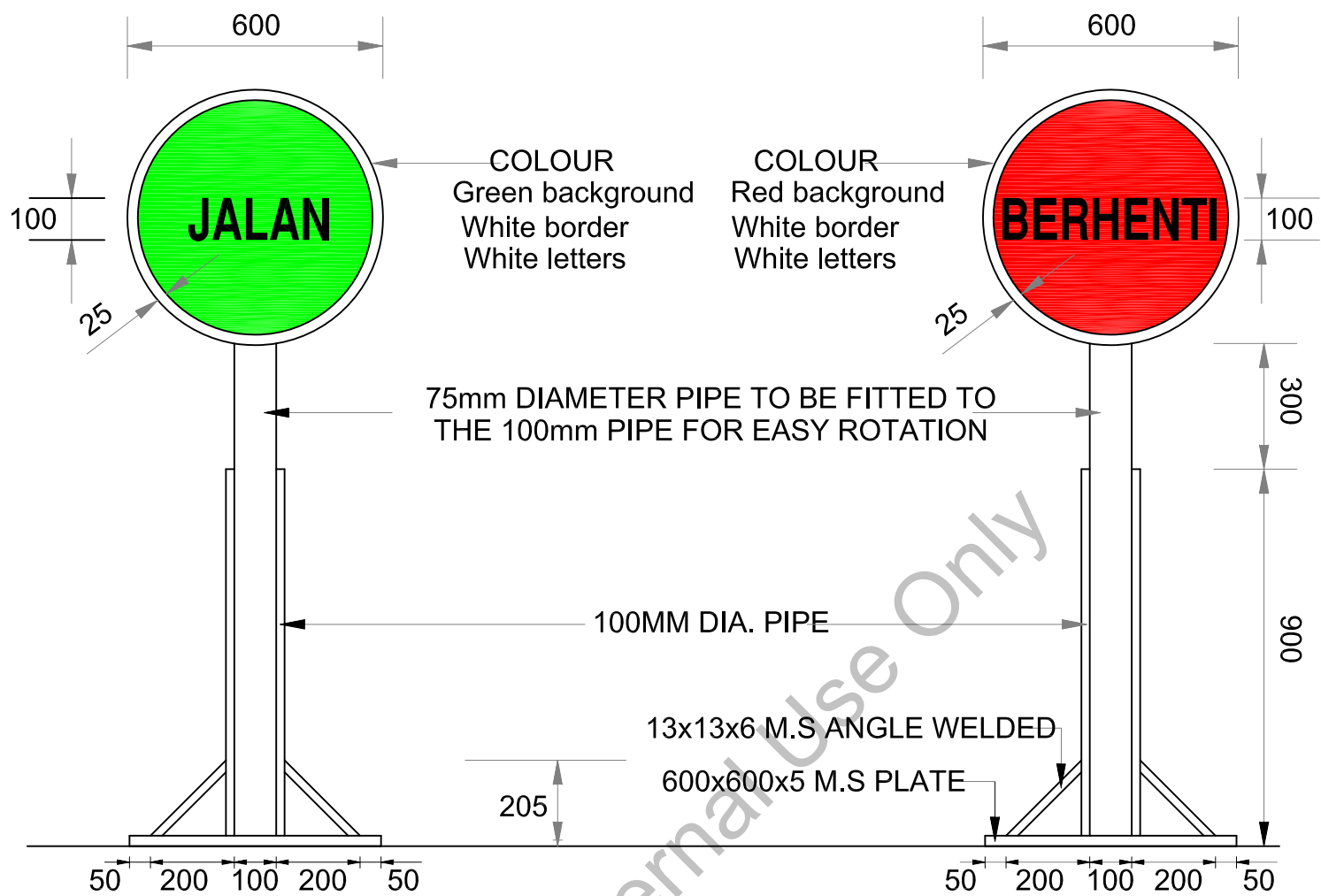
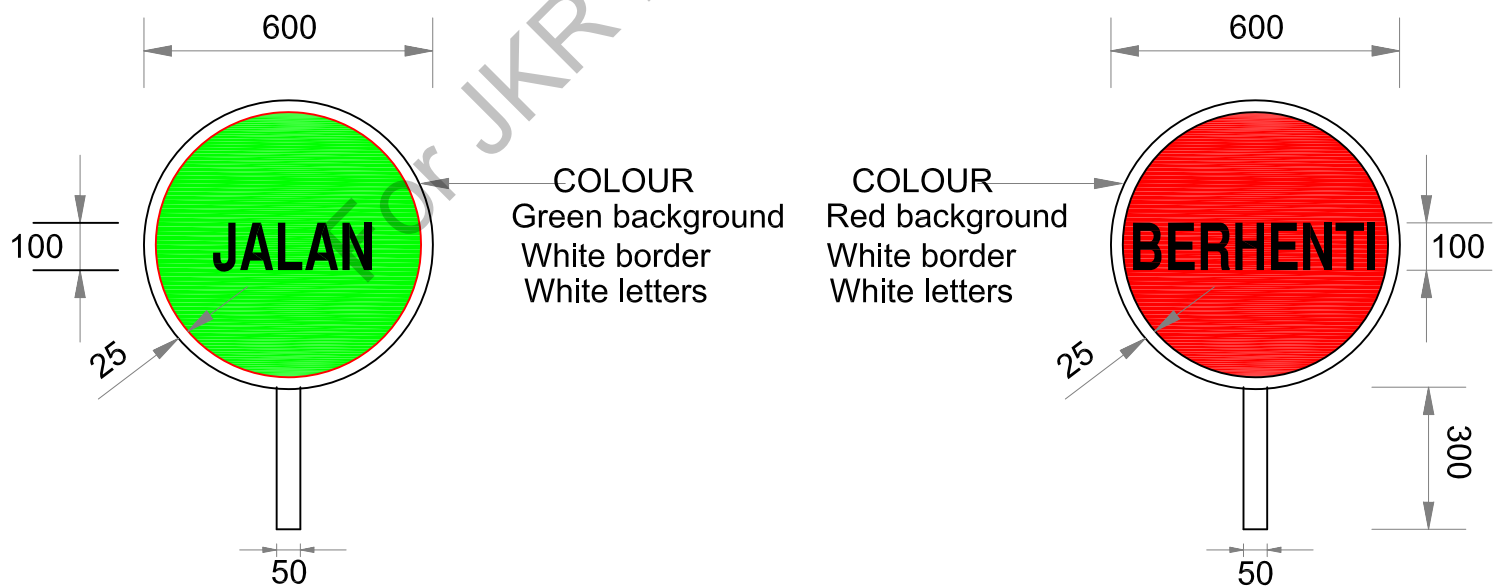

FIGURE 2.2: USE OF HAND SIGNALLING DEVICES BY FLAGGER

Scale : Not to scale



**TYPE 1: PADDLE TYPE**



**TYPE 2: HAND DISC STOP/GO CONTROL SIGN**



FIGURE 2.3: HAND SIGNAL CONTROL

## 1. TRAFFIC GUIDANCE CONE

COLOUR :

Red or orange colour with reflective strips which shall be white high intensity prismatic retro reflective sheeting

WEIGHT:

Min. 2.0 kg

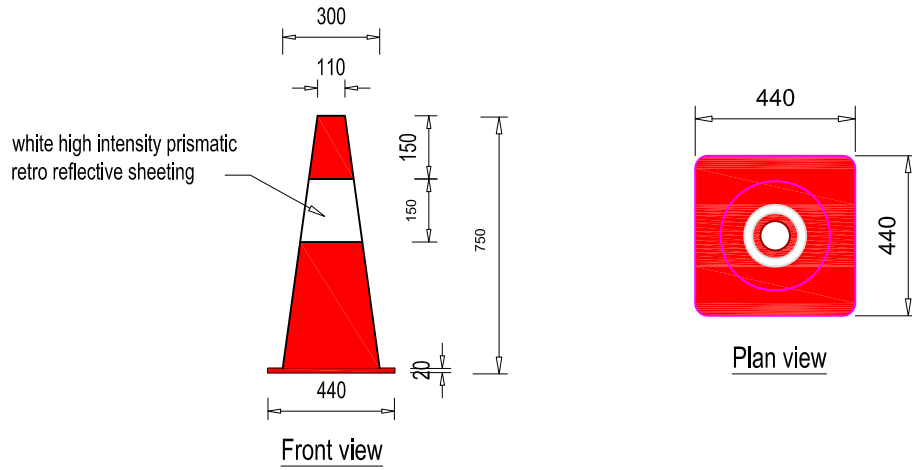

## 2. TRAFFIC SUPER CONE

COLOUR :

Red or orange colour with reflective strips which shall be white high intensity prismatic retro reflective sheeting

WEIGHT:

Min. 5.0 kg

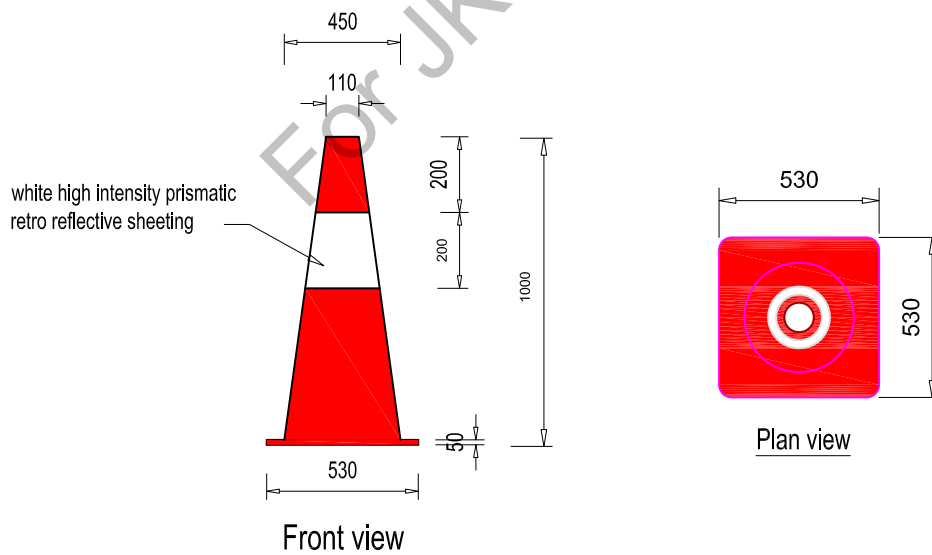

### 3. PLASTIC BARRIER

COLOUR :  
Red and white

DIMENSION :  
Min. 1000 mm (L) X 800 mm (H) X 500 mm (W)

WEIGHT :  
Min. 10.0 kg dry

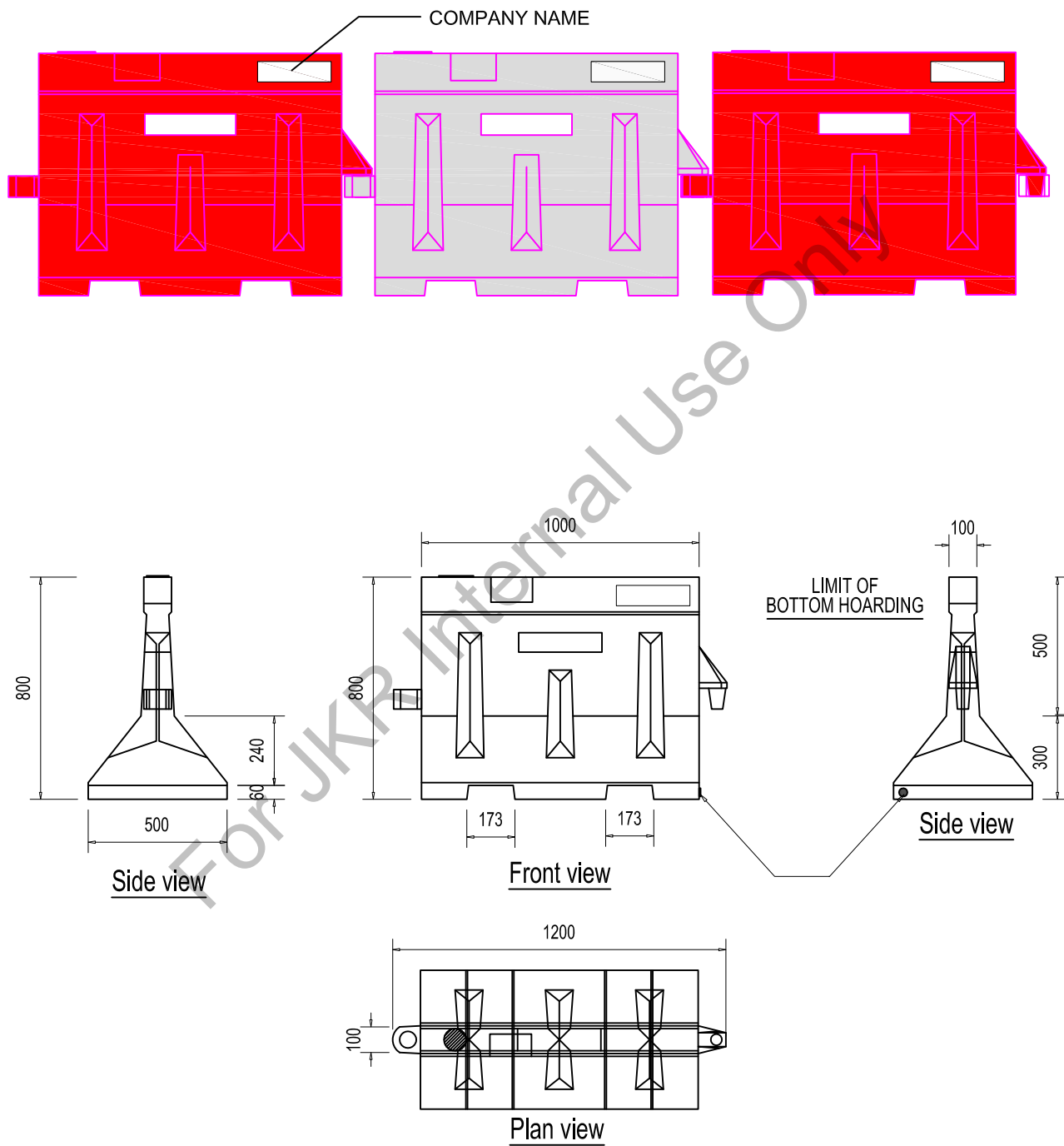

## PART TWO: TRAFFIC MANAGEMENT EQUIPMENT

Scale : Not to scale

#### 4. CONCRETE BARRIER

COLOUR :  
Black and yellow

DIMENSION :  
Min. 1000 mm (L) X 800 mm (H) X 500 mm (W)

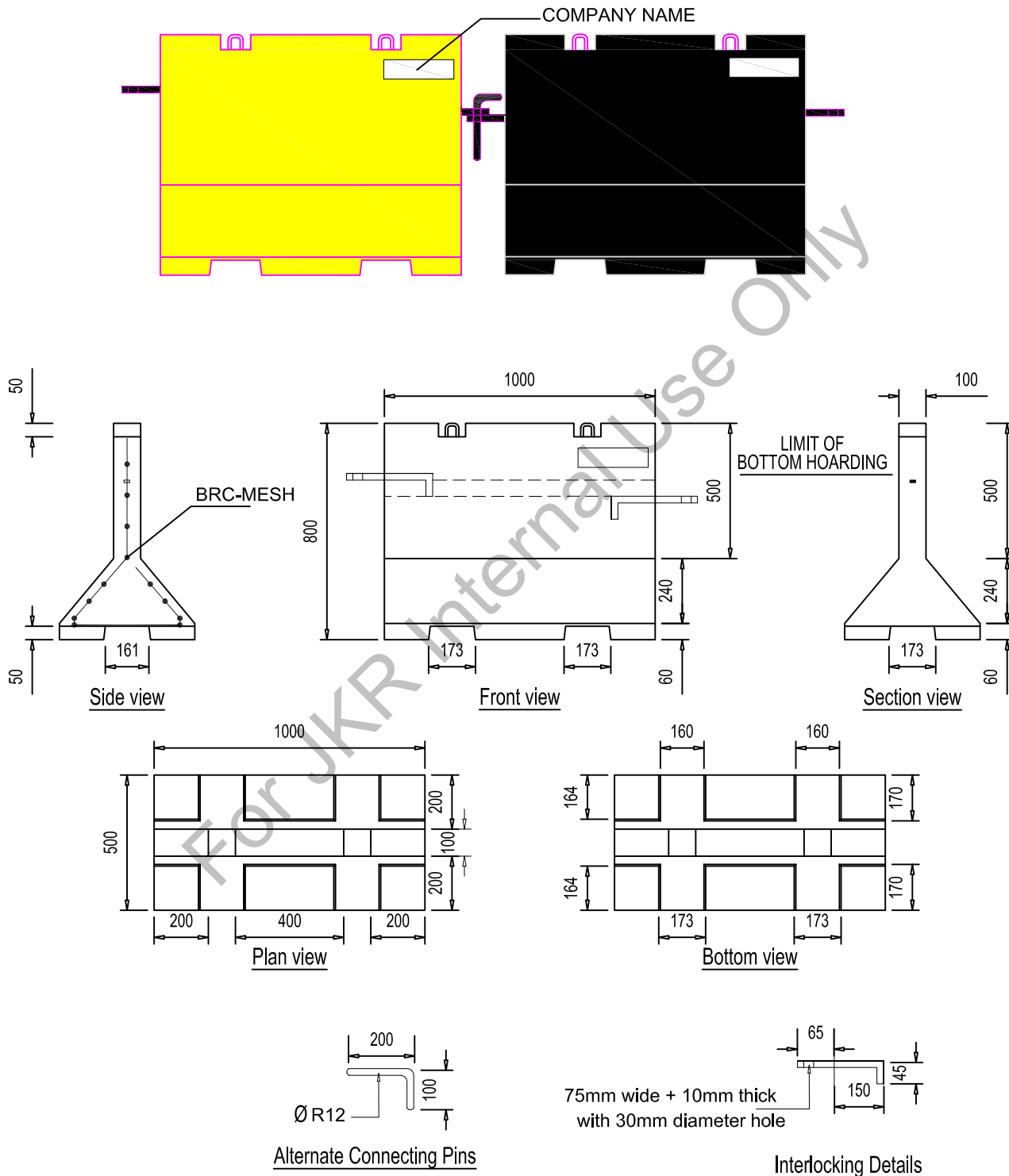

### PART TWO: TRAFFIC MANAGEMENT EQUIPMENT

Scale : Not to scale

5. PLASTIC HOARDING

COLOUR :  
Red and white

DIMENSION :  
Min. 1200 mm (L) X 1140 mm (H) X 60 mm (W)

WEIGHT :  
Min. 10.0 kg dry

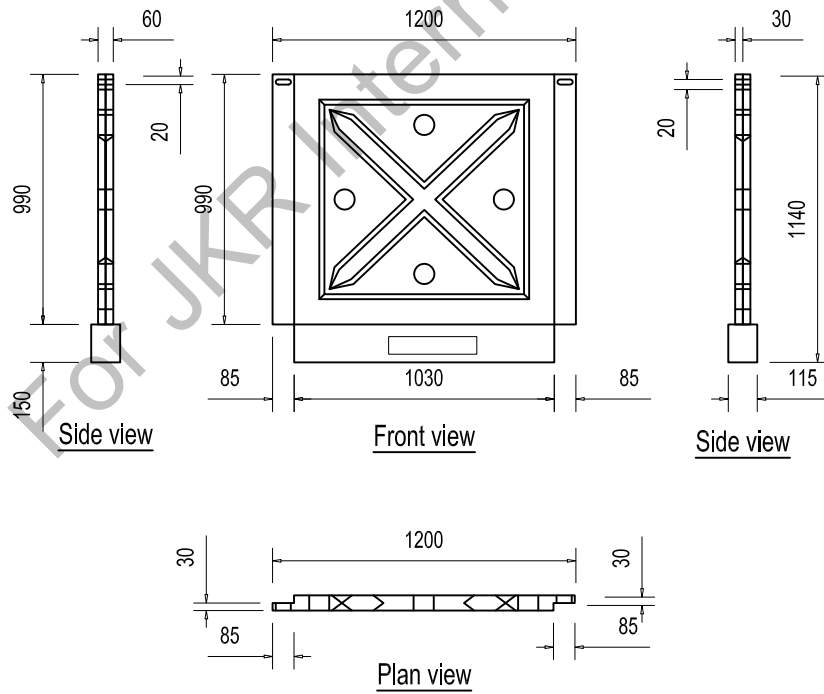
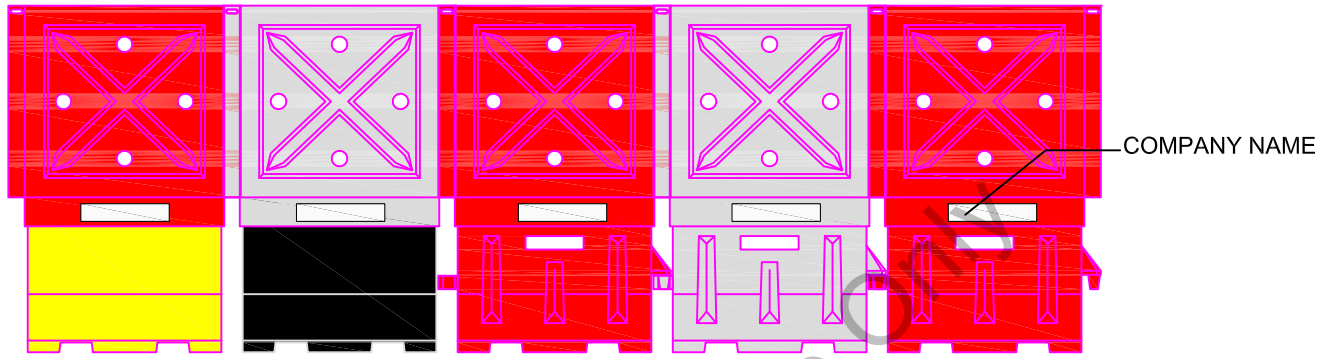

PART TWO: TRAFFIC MANAGEMENT EQUIPMENT

Scale : Not to scale

## 6. DELINEATOR STRING

COLOUR :

Red (HIP), White (HIP), Yellow (HIP) or Fluorescent Orange

DIMENSION :

75 mm (L) X 75 mm (W) double sided tied to string at 1000mm c/c

Notes;

- length of the string shall be 50 m long
- safe to use as no metal parts are used
- flexible & durable
- easy to install and maintain,

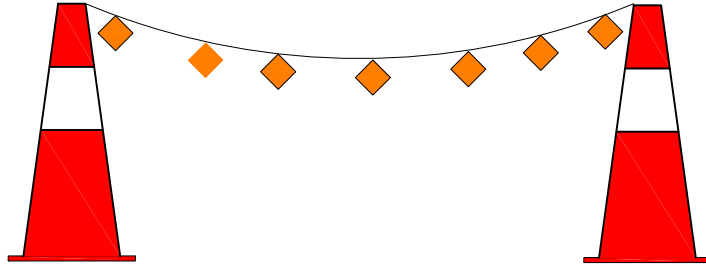

## 7. FLASHING LIGHT (BLINKERS)

COLOUR :

Amber

LUMINOUS :

2 pcs super bright LED

POWER :

1 or 2 pcs 4R25 6V battery

FUNCTION :

blinking at 65+5 times/min

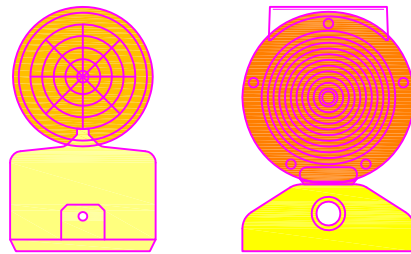

## PART TWO: TRAFFIC MANAGEMENT EQUIPMENT

Scale : Not to scale

## 8. FLASHING ARROW

### COLOUR :

LED : Amber  
Board / Poles: Black

### Notes;

- solar powered and able to work min. 12 hours,
- LED Strip Dimension : 8 mm (W) X 2 mm (H),
- LED / Lamp : 60 LED Per meter or 3 LED per 2 inch,
- Minimum sight distance : 800 m, maximum height : 2500 mm from existing ground level (EGL).
- built-in solar panel with fully automatic rechargeable system,
- super bright led for continuous operations and longer life span,
- fully function in heightened visibility and all weather conditions,
- easy installation with no cable required,
- durable, reliable and maintenance free,

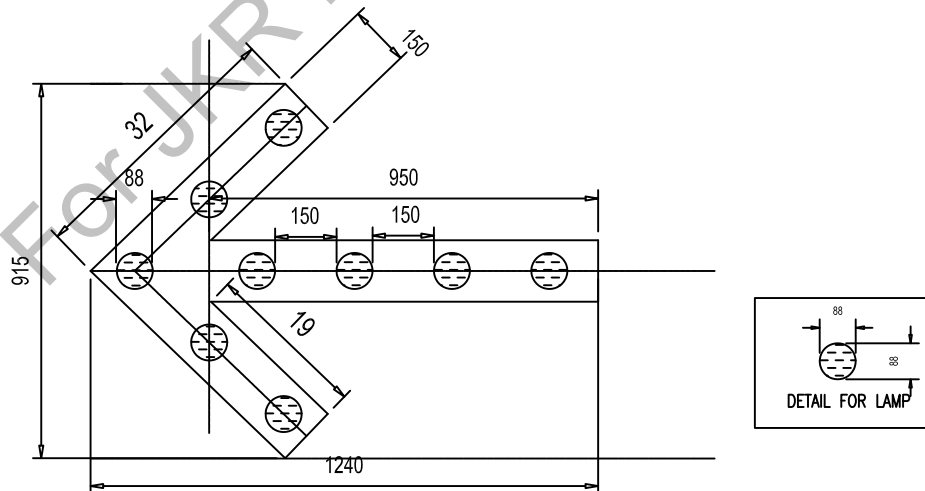
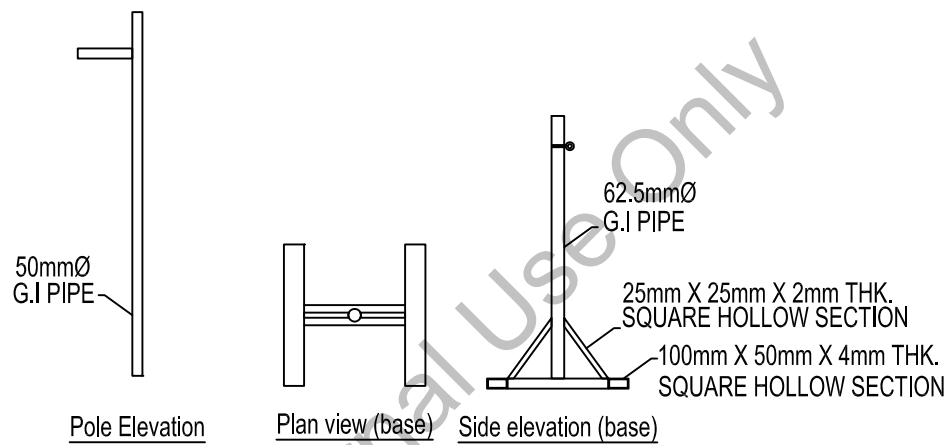

## PART TWO: TRAFFIC MANAGEMENT EQUIPMENT

Scale : Not to scale

## 9. CHEVRON LIGHT

### COLOUR :

LED : Amber  
Board / Poles: Black

### Notes;

- solar powered and able to work min. 12 hours,
- LED Strip Dimension : 8 mm (W) X 2 mm (H),
- LED / Lamp : 60 LED Per meter or 3 LED per 2 inch,
- Minimum sight distance : 800 m, maximum height : 2500 mm from existing ground level (EGL).
- built-in solar panel with fully automatic rechargeable system,
- super bright led for continuous operations and longer life span,
- fully function in heightened visibility and all weather conditions,
- easy installation with no cable required,
- durable, reliable and maintenance free,

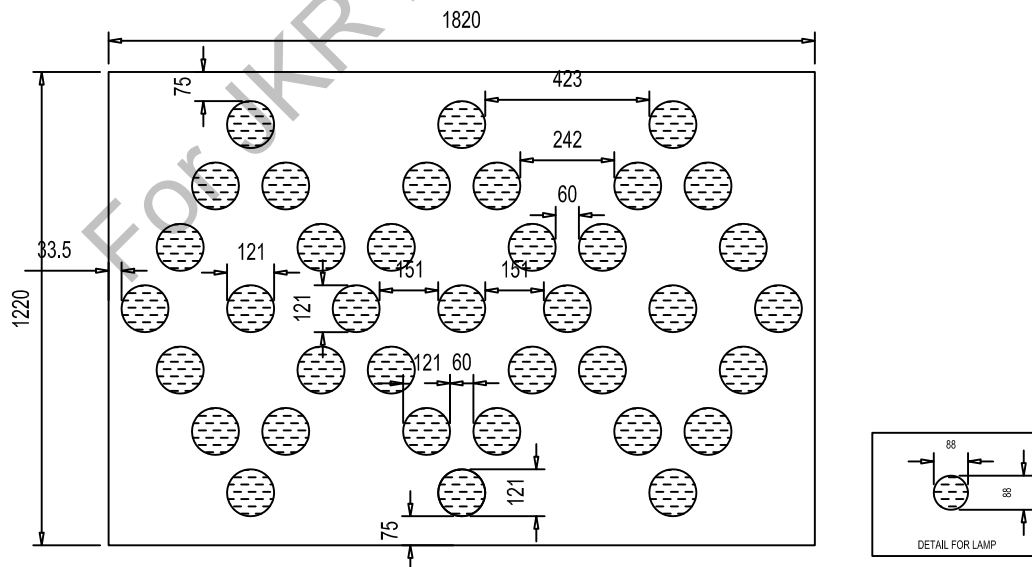
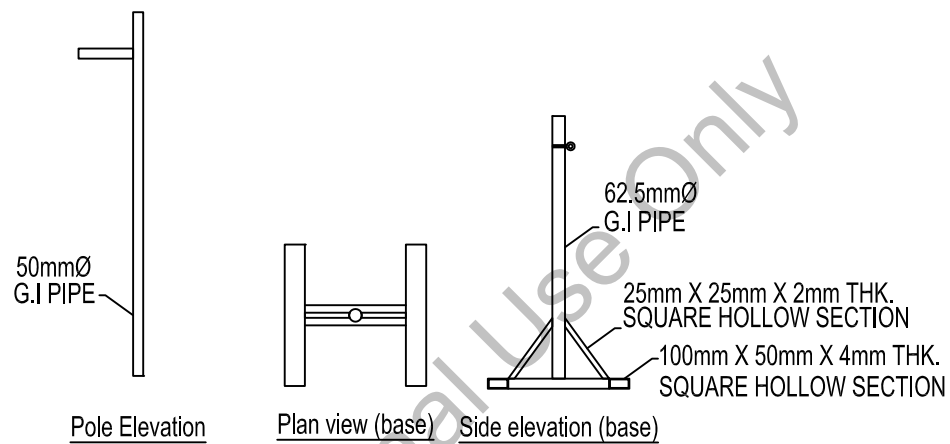

## PART TWO: TRAFFIC MANAGEMENT EQUIPMENT

Scale : Not to scale

## 10. VARIABLE MESSAGING SYSTEM (VMS)

### POWER :

- i. 12v battery, 200AH deep cycle,
- ii. solar panels : 3\*125 watt panels,
- iii. voltage : 12v

### Notes;

- Visual : 5 color LED full matrix,
- Function;
  - i. onsite, SMS, GPRS (remote control),
  - ii. window compliant free automatic software updates,
  - iii. large storage up to 100 individual messages with various page sizes.

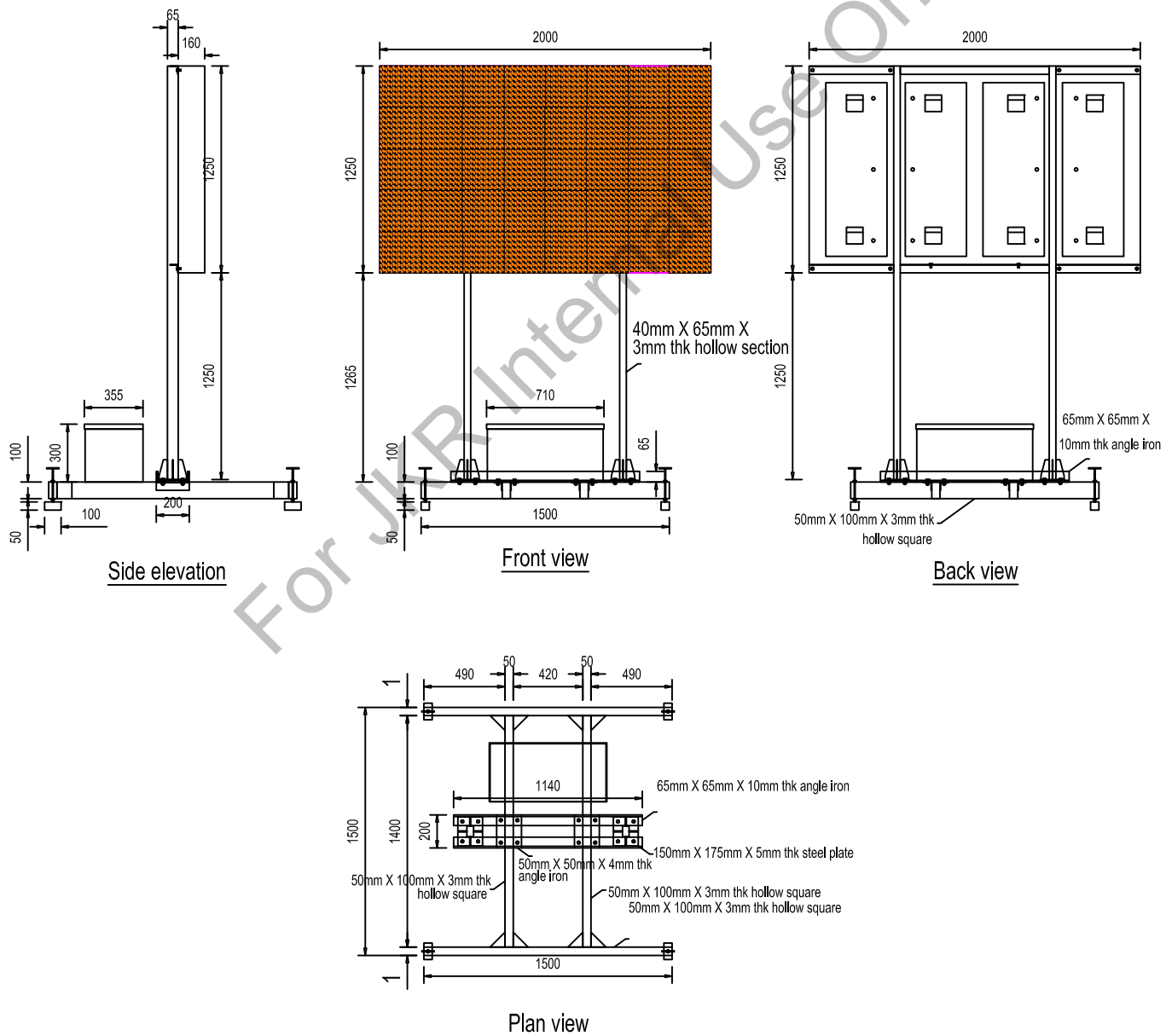

## PART TWO: TRAFFIC MANAGEMENT EQUIPMENT

Scale : Not to scale

# 11. DELINEATORS ON BARRIER

COLOUR :

Fluorescent Orange on both sides

DIMENSION:

115mm (H) x 50mm (W)

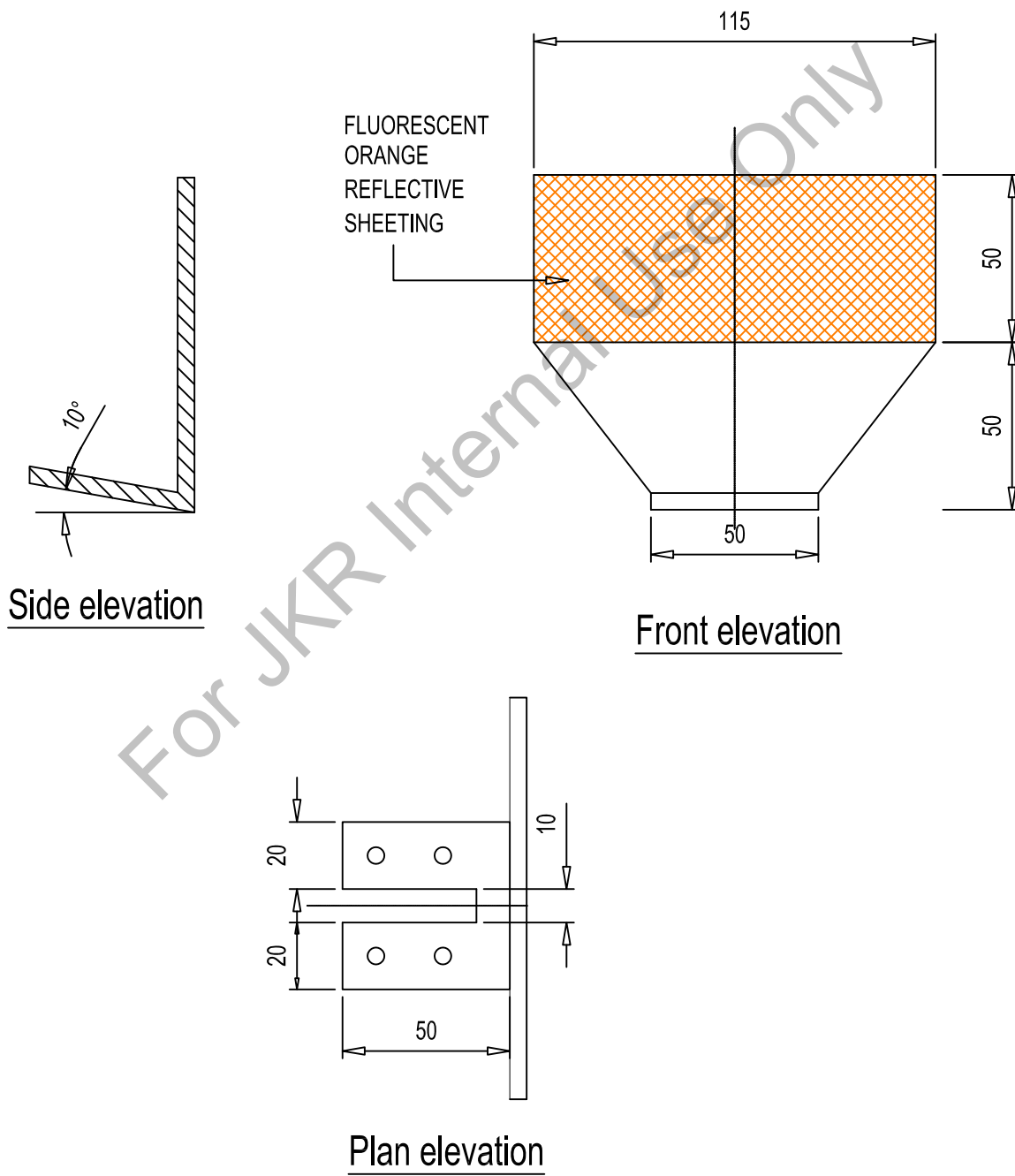

## PART TWO: TRAFFIC MANAGEMENT EQUIPMENT

## 12. TRAFFIC CONTROL PADDLE

COLOUR :

Red fluorescent prismatic retroreflective sheeting on both sides

DIMENSIONS:

Round in shape and 350mm diameter

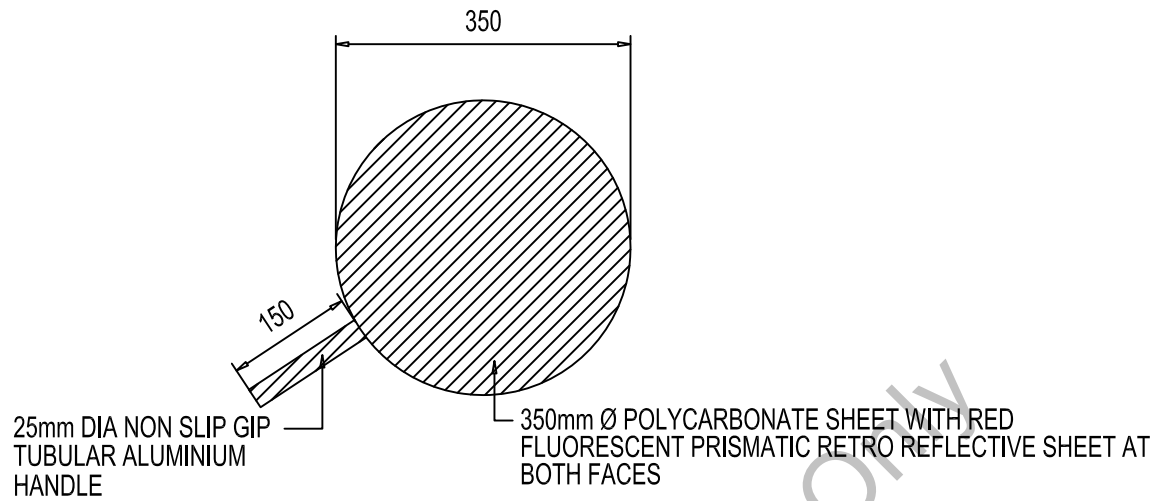

## 13. TRAFFIC BATTON LIGHT

COLOUR :

Red

DIMENSIONS:

40mm diameter and 260mm length

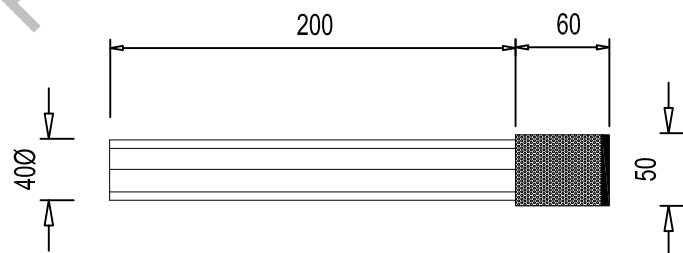

## PART TWO: TRAFFIC MANAGEMENT EQUIPMENT

Scale : Not to scale

121

# APPENDIX

For JKR Internal Use Only

## APPENDIX A

### BORANG PEMERIKSAAN RUTIN ZON KERJA

Projek : \_\_\_\_\_  
 Kontraktor : \_\_\_\_\_  
 Lokasi Tapak : \_\_\_\_\_  
 Nama TMO : \_\_\_\_\_

Tarikh : \_\_\_\_\_  
 Masa : \_\_\_\_\_

	ZON A - KAWASAN AMARAN AWAL ( <i>ADVANCE WARNING AREA</i> )	CATATAN	C.A.R. 1/ 2
i.	Papan Tanda Pemberitahuan	A1 A2 A3 A4 A5 A6 A7	
ii.	Papan Tanda Amaran Awal (AWAS)	A1 A2 A3 A4 A5 A6 A7	
iii.	Papan Tanda Orang Bekerja	A1 A2 A3 A4 A5 A6 A7	
iv.	Papan Tanda Lorong Sempit	A1 A2 A3 A4 A5 A6 A7	
v.	Papan Tanda Had Laju	A1 A2 A3 A4 A5 A6 A7	
vi.	Papan Tanda Anak panah	A1 A2 A3 A4 A5 A6 A7	
vii.	Penanda Garisan Jalan Sementara	G1 G2	
viii.	Keadaan Jalan	J1 J2 J3 J4	
	<b>ZON B - KAWASAN PERALIHAN (<i>TRANSITION AREA</i>)</b>	<b>CATATAN</b>	<b>C.A.R. 1/ 2</b>
i.	Papan Tanda Anak panah (3 Bilangan)	A1 A2 A3 A4 A5 A6 A7	
ii.	<i>Arrow Flasher / Chevron light</i>	K1 K2 K3	
iii.	<i>Blinkers</i> (Selang 10m)	B1 B2 B3 B4	
iv.	<i>Reflective Disc / Delineator String</i>	C1 C2	
v.	<i>Plastic Barrier</i>	D1 D2 D3 D4 D5 D6	
vi.	<i>Concrete Barrier</i>	E1 E2 E3 E4 E5 E6	
vii.	Kon Keselamatan	F1 F2 F3	
viii.	Pengawal Bendera	H1 H2 H3	
ix.	<i>Robotic Flagman</i>	I1	
x.	Penanda Garisan Jalan Sementara	G1 G2	
xi.	Keadaan Jalan	J1 J2 J3 J4	
	<b>ZON C - KAWASAN KELEGAAN (<i>BUFFER AREA</i>)</b>	<b>CATATAN</b>	<b>C.A.R. 1/ 2</b>
i.	Papan Tanda (Orang Bekerja / Had Laju)	A1 A2 A3 A4 A5 A6 A7	
ii.	<i>Blinkers</i>	B1 B2 B3 B4	
iii.	<i>Reflective Disc / Delineator String</i>	C1 C2	
iv.	<i>Plastic Barrier</i>	D1 D2 D3 D4 D5 D6	
v.	<i>Concrete Barrier</i>	E1 E2 E3 E4 E5 E6	
vi.	Kon Keselamatan	F1 F2 F3	
vii.	Penanda Garisan Jalan Sementara	G1 G2	
viii.	Pengawal Bendera	H1 H2 H3	
ix.	Keadaan Jalan	J1 J2 J3 J4	
x.	<i>Shadow Vehicle</i>	L1 L2 L3	

4 ZON D - KAWASAN KERJA (WORK AREA)								CATATAN	C.A.R. 1/ 2
i. Papan Tanda (Orang Bekerja / Had Laju)	A1	A2	A3	A4	A5	A6	A7		
ii. <i>Blinkers</i>	B1	B2	B3	B4					
iii. <i>Reflective Disc / Delineator String</i>	C1	C2							
iv. <i>Plastic Barrier</i>	D1	D2	D3	D4	D5	D6			
v. <i>Concrete Barrier</i>	E1	E2	E3	E4	E5	E6			
vi. Penanda Garisan Jalan Sementara	G1	G2							
vii. Keadaan Jalan	J1	J2	J3	J4					
5 ZON E - KAWASAN TAMAT (TERMINATION AREA)								CATATAN	C.A.R. 1/ 2
i. Papan Tanda Mohon Maaf	A1	A2	A3	A4	A5	A6	A7		

Nota : C.A.R. = Permintaan Tindakan Pembedulan (*Corrective Action Request*)  
 C.A.R. 1 = Tindakan pembedulan diambil dalam masa 24 jam.  
 C.A.R. 2 = Tindakan pembedulan diambil dalam masa 2-5 hari.

Cc :  Pasukan Projek (JKR)  
 Resident Engineer (RE)  
 Jurutera Projek

Maklumat tambahan / gambar dilampirkan :  Ya  Tidak

Disediakan Oleh Pegawai Pengurusan Trafik (TMO) :

\_\_\_\_\_  
 Nama :  
 Tarikh :

Disemak oleh Pengurus Projek (PM) :

\_\_\_\_\_  
 Nama :  
 Tarikh :

Diambil Tindakan Oleh TMO :

\_\_\_\_\_  
 Nama :  
 Tarikh :

**BUTIRAN KETIDAKPATUHAN PENGURUSAN TRAFIK**

PERALATAN TRAFIK	KOD	NO	KETIDAKPATUHAN PENGURUSAN TRAFIK
Papan Tanda	A	1	Rosak
		2	Pudar / Tidak jelas
		3	Tidak mencukupi
		4	Jatuh / Bengkok
		5	Tidak dapat dilihat / Tersembunyi
		6	Tidak mengikut spesifikasi
		7	Lokasi tidak betul
Blinkers	B	1	Rosak
		2	Tidak berfungsi
		3	Tidak beroperasi dengan betul
		4	Tidak dipasang dengan jarak yang betul
Reflector Disc	C	1	Tidak dipasang dengan jarak yang betul
		2	Tidak memantul cahaya
Plastic Barrier	D	1	Pemasangan tidak berselang-seli (warna putih & merah)
		2	Rosak
		3	Sampah / habuk di antara <i>barrier</i> / kotor
		4	<i>Reflective plate</i> tiada / tidak mencukupi
		5	Tidak diisi dengan air / Air tidak mencukupi
		6	Tidak disusun dengan betul
Concrete Barrier	E	1	Pemasangan tidak berselang-seli (warna kuning & hitam)
		2	Rosak
		3	Sampah / habuk di antara <i>barrier</i> / kotor
		4	<i>Reflective plate</i> tiada / tidak mencukupi
		5	Tidak disusun dengan betul
		6	Tiada <i>concrete barrier</i> di lokasi kritikal (pengorekan dalam di sebelah jalan selekoh tajam, pengasingan kerja <i>falsework</i> / <i>scaffold</i> , kawasan berisiko banjir dan <i>rigid structure</i> )
Kon Keselamatan	F	1	Sampah / habuk di antara kon keselamatan / kotor
		2	<i>Reflective strip</i> tiada / tidak mencukupi dan/atau berat tidak mencukupi dan/atau rosak
		3	Tidak disusun dengan betul
Penanda Garisan Jalan Sementara	G	1	Pudar / mengelirukan
		2	penanda garisan jalan sedia ada yang tidak digunakan tidak dipadam
Pengawal Bendera	H	1	Pengawal Bendera tidak dilengkapi dengan pakaian seragam
		2	Tiada Pengawal Bendera di laluan masuk tapak / penutupan jalan / lencongan jalan
		3	Pengawal Bendera tidak dilengkapi dengan wisel dan bendera / <i>baton light</i>
Robotic Flagman	I	1	Tidak berfungsi
Keadaan Jalan	J	1	Jalan berlubang / permukaan jalan tidak rata
		2	Kotor disebabkan oleh lumpur / tanah dari tapak projek
		3	Jalan sempit / lebar jalan tidak mencukupi
		4	Lampu jalan tidak berfungsi / kawasan gelap
Arrow Flasher	K	1	Tidak berfungsi
		2	Rosak
		3	Tidak mengikut spesifikasi
Shadow Vehicle	L	1	Tidak disediakan
		2	Tidak diletakkan dengan betul
		3	Kenderaan tidak dilengkapi / tidak berfungsi mengikut keperluan

## APPENDIX B: COLOUR CODE FOR TRAFFIC SIGN

The following colour code has been established and identified by JKR as being appropriate for use in conveying traffic control information

Note:

The colours coded below are used for road furniture, other than traffic sign faces, such as road markings, traffic signal and traffic sign posts, guardrails, kerbs and so on, and should be of gloss finish paint or, of higher quality material.

Yellow	–	No 356 British Standard 381C (Golden Yellow)
White	–	Part 1 clause 1.3.2 and 1.3.3 British Standard 873
Black	–	Part 1 clause 1.3.2 and 1.3.3 British Standard 873
Orange	–	British Standard 0.004

Note:

The colours used for all traffic sign faces should be comparable to that formed by the chromaticity coordinates, and should be of retro-reflective material.

Chromaticity Coordinates

COLOUR	1		2		3		4	
	x	y	x	y	x	y	x	y
White	0.303	0.300	0.368	0.366	0.340	0.393	0.274	0.329
Yellow	0.498	0.412	0.557	0.442	0.479	0.520	0.438	0.472
Orange	0.558	0.352	0.636	0.364	0.570	0.429	0.506	0.404
Green	0.026	0.399	0.166	0.364	0.286	0.446	0.207	0.771
Red	0.648	0.351	0.735	0.265	0.629	0.281	0.565	0.346
Blue	0.140	0.035	0.244	0.210	0.190	0.255	0.065	0.216
Brown	0.430	0.340	0.610	0.390	0.550	0.450	0.430	0.390
Fluorescent Yellow Green	0.387	0.610	0.369	0.546	0.428	0.496	0.460	0.540
Fluorescent Yellow	0.497	0.520	0.446	0.483	0.512	0.421	0.557	0.442
Fluorescent Orange	0.583	0.416	0.535	0.400	0.595	0.351	0.645	0.355

Source: ASTM D4956-09: Standard Specification for Retro-reflective Sheeting for Traffic Control

For JKR Internal Use Only